

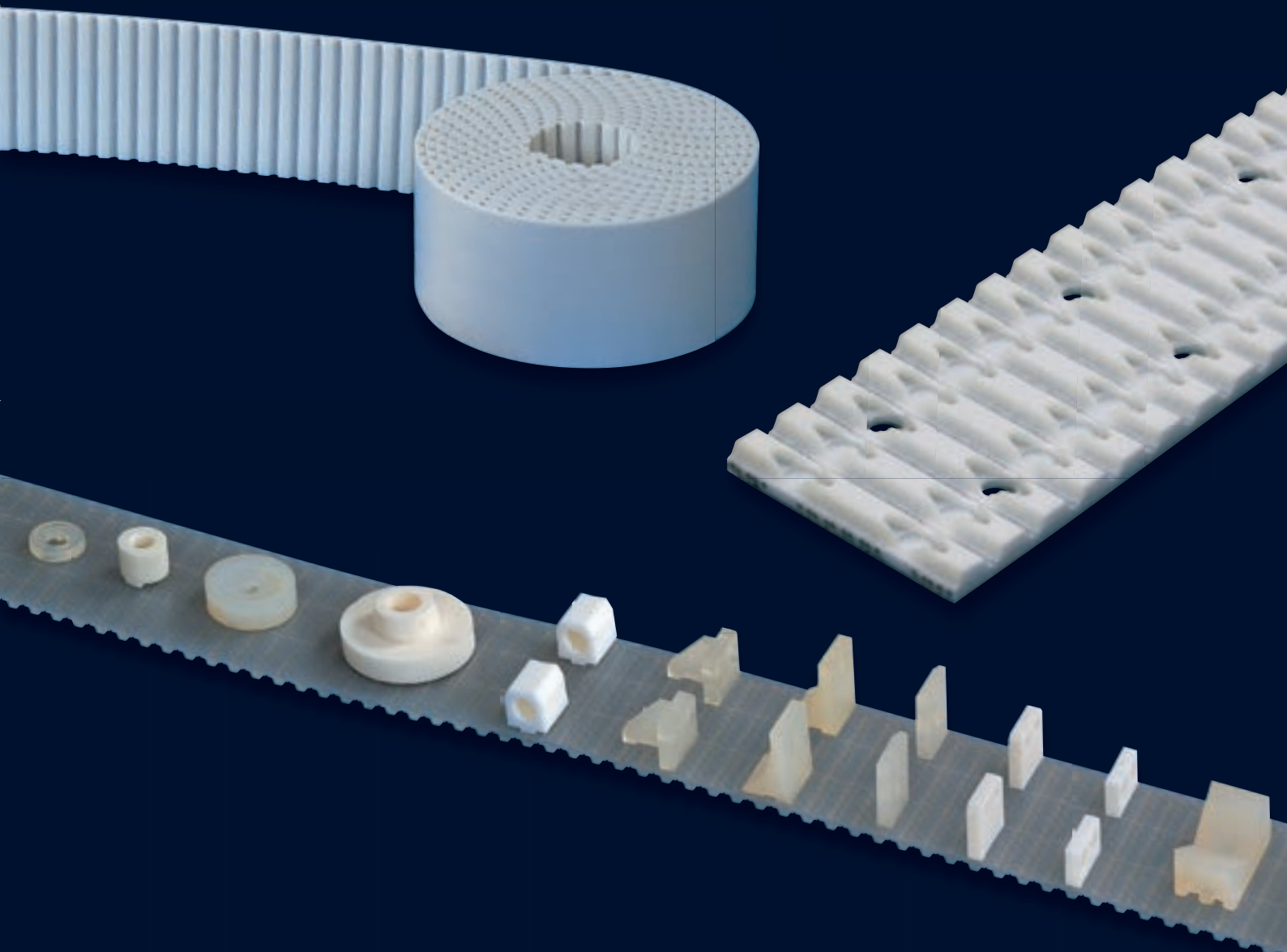





● Cat. No. 190E-05-2022

# IRON RUBBER BELT





NOK CORPORATION



# Precautions before Using Iron Rubber Belt

 <b>Danger</b>	Due to mishandling, there is a possibility of immediate danger of death of a user or serious injury to a user.
 <b>Warning</b>	Due to mishandling, there is a possibility of death of user or serious injury to a user.
 <b>Caution</b>	Due to mishandling, there is a possibility of danger of injury to a user or a possibility of property damage.



## Precautions for storing

-  **Caution** • Do not fold tightly.
-  **Caution** • Do not store in stacked or in folded conditions to avoid bending tendency.
-  **Caution** • When storing, keep it in a cool and dark place. (Avoid extremely high or low temperature, moisture, and direct sunlight.)
  - Do not scratch the pulley when storing.

## Precautions for installation

-  **Danger** • Be sure to turn off the power and check that the machine is stopped, prior to perform installation.
-  **Caution** • Install after shortening the distance between the shafts or loosening the tension pulley. Belt or pulley may be damaged or the belt life may be shortened if the pulley is squeezed in with a tool.



## Precautions in operation

-  **Danger** • Be sure to use a safety cover for a rotating part.
-  **Warning** • When it is anticipated that static electricity from a belt conveyor may cause fire or malfunction of a control device, neutralization apparatus should be set on the machine side.
  - Avoid involvement of foreign objects.
  - Exchange a belt if abrasion, tooth bottom crack, or belt back crack is found.
  - Exchange a pulley if abrasion and corrosion are found.

## Precautions for spent belts

-  **Caution** • Do not burn a spent belt. Toxic gas may be generated.
  - When disposing a product, treat it as an industrial waste.

## Other precautions

-  **Danger** • Do not use the belts for purposes other than originally intended.
-  **Danger** • Be sure to install an additional safety device, when it is anticipated that cutting of a belt may cause idle running, self-running, or stopping of the machine, which may result in an accident causing injury or death, or a serious accident.
-  **Caution** • Do not use a belt as insulation.

- All compatibility data, application information, design & material information and technical data in this catalogue are compiled as a reference material to make a basic packing selection. A selected standard design from this catalogue may not conform to the actual use of an application, clue to unknown factors in the application. Please confirm the actual compatibility of a selected product with your application before using it.
- The contents of this pamphlet may be changed without prior notice for product improvement.

The belts in this catalogue are neither designed nor manufactured to the use for medical application.  
Please do not use the products in this catalogue for the application physically contacting body fluid or biosystem, or as a transplant material to human body.

# INDEX

## Characteristics and types

Structure and Characteristics .....	3
Types (Flex type, Joint type, Linear type) .....	4
Introducing the new specifications (SP specifications) .....	5
Model and Type .....	6
Specifications .....	8

## Selecting a belt

Selection conditions and instructions .....	10
Selection procedure .....	11
Example of selection .....	12
List of formulas .....	16
Acceptable value .....	17
Diagram of simple version of the belt .....	18

## Method used to select the dimensions

Iron Rubber Belt models .....	20
Dimensions and specifications (How to read the table) .....	21

## Dimensions and specifications

MA belt (MA3, MA5, MA8) .....	22
AT belt (AT5, AT10, AT20) .....	25
Trapezium teathed belts (meters) (T5, T10, T20) .....	28
Trapezium teathed belts (inches) (MXL, XL, L, H, XH) .....	31
Double-sided teathed belts (DT5, DT10, DH) .....	36
Self-tracking belts (MA5-V, AT10-V, T5-V, T10-V, L-V) .....	39
Wide teathed belts (Wide T10, Wide H) .....	44
Flat belts (F12, F20, F60) .....	46
Self-tracking flat belts (F10-V, F20-V) .....	49
Double width teathed belts (AT10, T10, H) .....	51

## FAT belt

Characteristics of the product, Product shape .....	54
Dimension, Example of model dimension indication .....	55

## Profile

Characteristics .....	56
Profile belt design instructions .....	58
Profile dimensions table .....	60
Special rears, Machining .....	75

## Design Instructions

Initial tension (mounting tension) .....	76
Instructions when using teathed pulleys .....	78
Damage to belts, causes, and countermeasures .....	80
Belt dimension tolerance .....	82

## Rubber material

Material characteristics, Oil & Abrasion resistance .....	83
Mildewproof & antimicrobial, Chemical resistance .....	84

## Applications

Linear drive, Accumulation & Sandwich, Synchronous conveyor .....	86
Vertical & Magnetic, Inclined, Vacuum conveyor, etc. ....	87

# *Pioneer in the multi-function*

*Iron Rubber of excellent mechanical strength and abrasion resistance, etc.  
Ensures excellent performance as a next-generation power transmission and  
conveyor belt for use in a variety of production lines*

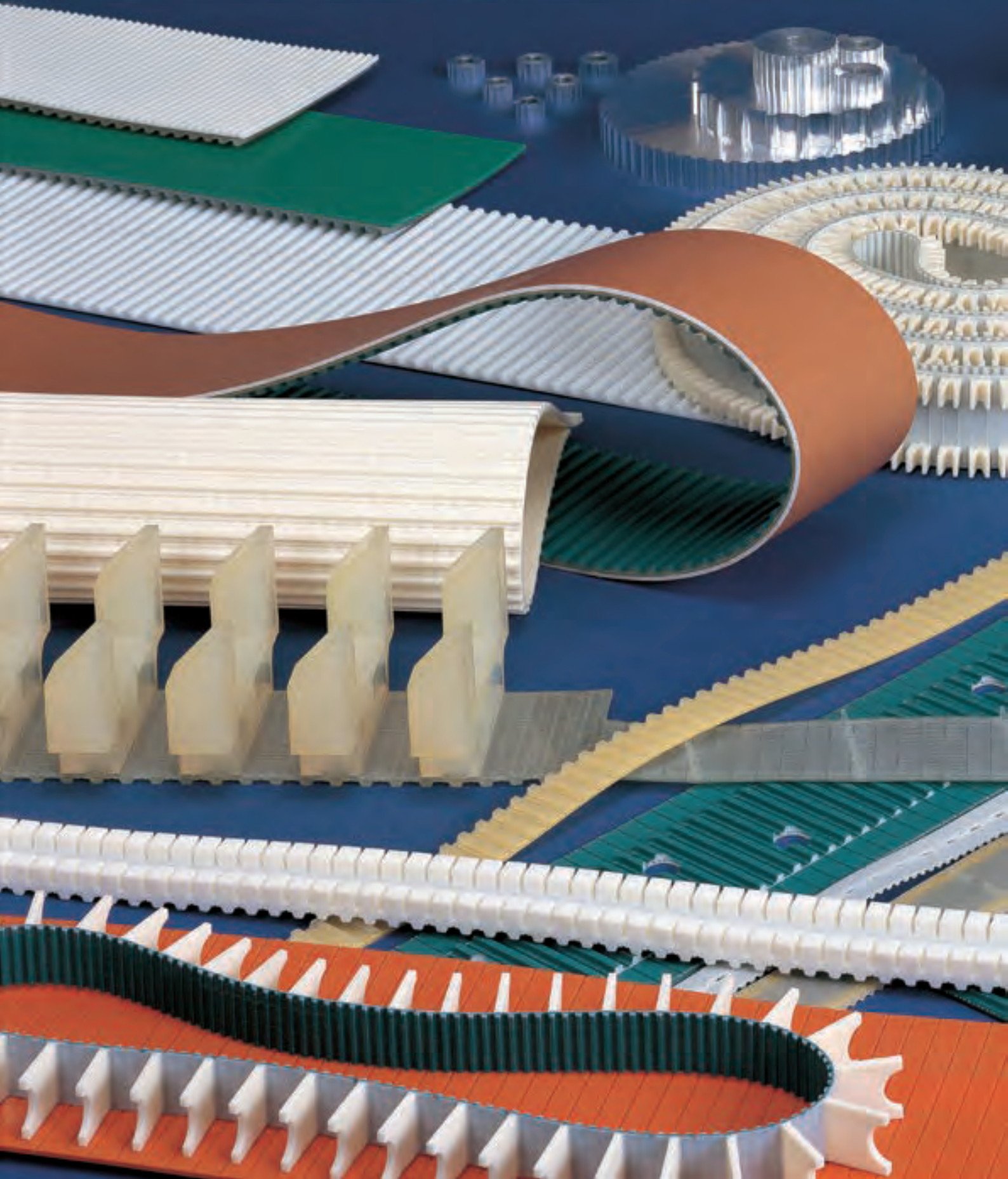

# belt field!

## Iron Rubber™ Belt Structure and Characteristics

The Iron Rubber Belt portfolio consists of standard belt, MA belt and AT belt. The standard belt is based on ISO standards. The MA belt provide smooth tracking and good positioning accuracy through the application of circular teeth. In addition, high-torque/high tensile AT belts with an enlarged tooth cross-section are also available.

### Structure

Iron Rubber (urethane elastomer), which determines the longevity of the belt, is utilized as the belt covering itself and also the rubber of the teeth. One-piece molded belts incorporate high-tensile steel cord (or aramid fiber cord/stainless steel cord) as the tension members. Toothed belts can be fabricated and adapted to a more extensive range of lengths through the use of these two superior materials and our unique and innovative proprietary method of manufacturing them. (Iron Rubber is the NOK trade mark used for urethane elastomer.)

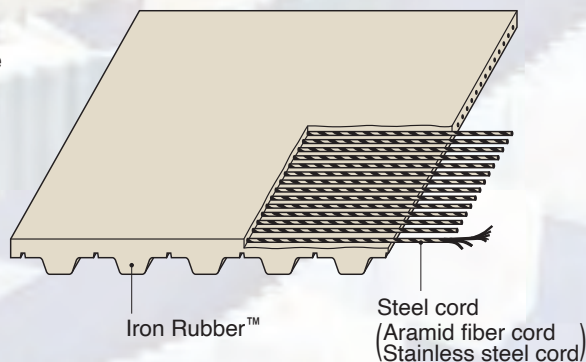

### Characteristics

**The material is Iron Rubber, therefore acknowledgeable attributes are:**

- Superior abrasion resistance
- Superior mechanical strength
- Long track record of foodstuff applications
- Available with midewproof and antimicrobial features
- Superior ozone resistance

### Superior workability

- Grinding
- Perforating
- Cutting

Belts can be customized in order to meet the most stringent parameters.

**V-guide one-piece molded types are also available**

- Pulley flanges are unnecessary.
- V-guide sections are highly accurate and reliable
- The application of pulleys with smaller diameters is also possible, because notches are established in the V-guide.

**Profiles (attachments) can be affixed**

- Profiles (attachments) to suit the parameters of transportation can be attached by welding them to the back side of the belts.

**The surface can be augmented with a diverse range of features**

- Slippage over the pulley or guide rail can be improved by one-piece molding of nylon facing into the tooth surface.
- Nylon facing can be one-piece molded into the back side and slippage of the transported article can be improved.
- Rough top/synthetic leather/polyurethane form pad/ etc. can be attached to the back side to protect the transported articles or give the belt cushioning.

The scope of application, performance data and numerical values listed in this catalogue should only be used as a reference for selection. These technical specifications might not be applicable in certain cases of actual application due to unknown factors or depending on the circumstances (Parameters of desired task). Please confirm compatibility before employing any of our products.

# Types

The Iron Rubber Belt portfolio consists of a comprehensive range of state-of-the-art belts such as toothed belts and flat belts. They are classified as flex-type, joint-type and linear-type depending on the method of manufacture.

## F Flex type



Endless toothed belts of one-piece molded Iron Rubber in which helically wound high tensile steel cord (or stainless steel cord) is deployed. A one-piece molded toothed belt with the desired number of teeth can be manufactured to match the axis spacing of the apparatus.

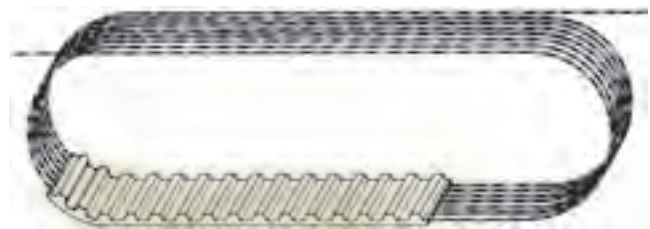

## J Joint type



Toothed belts of one-piece molded Iron Rubber in which high tensile steel cord (or aramid fiber cord) is deployed in the parallel axis can be spliced into an endless toothed belt with the desired number of teeth.

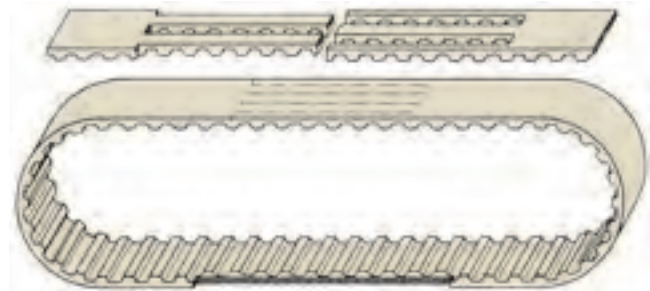

## L Linear type

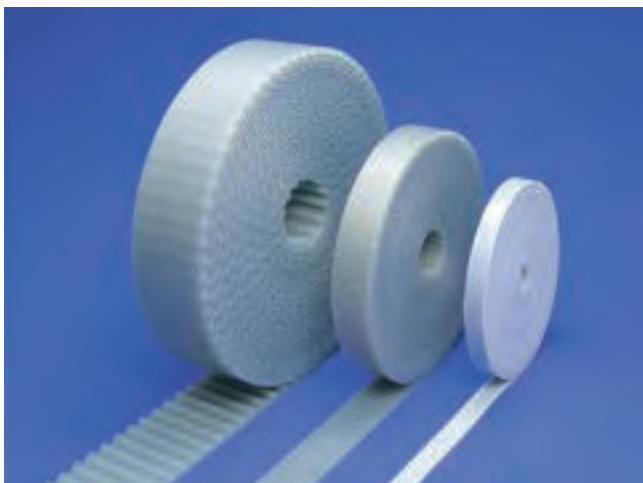

Open-ended toothed belts employing the joint type, as is. Stable synchronous transmission is facilitated by the tension members deployed in the parallel cords.



**Introducing the new specifications**

**The flex type belt can be manufactured up to a maximum circumference of 30 m.  
[Supports up to 1.3 times the circumference of conventional models  
(conventional maximum circumference of 24 m)]**

**SP specifications for flex belts (SP: Standard Plus)**

The performance of flex type Iron Rubber Belts has been further improved further while still maintaining their conventional characteristics

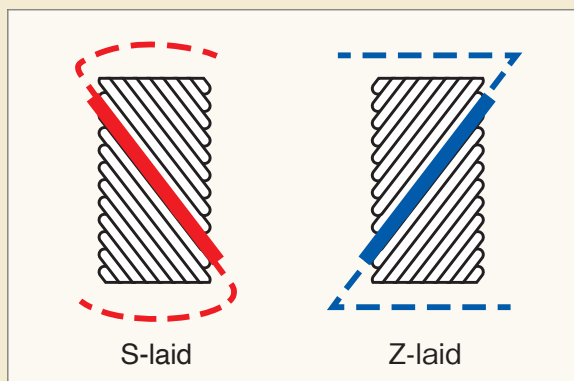

**Double wrapped cords adopted**

[Conventional specification]

Single wrapped S-laid cords

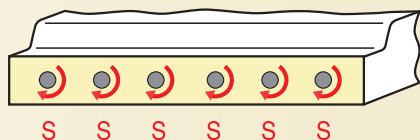
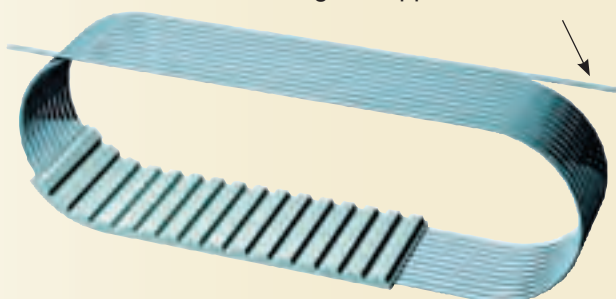

S S S S S S



Easily leans to one side

[SP specification]

Double wrapped S-laid & Z-laid cords

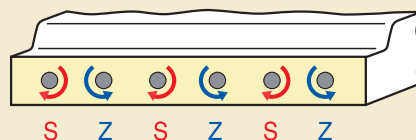
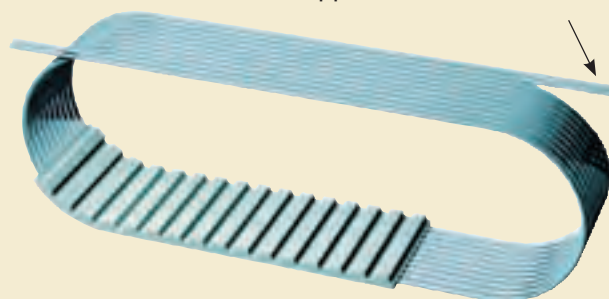

S Z S Z S Z



Neutral

[Belt cross-section] Conceptual diagram

The SP specification reduces the degree to which the belt will lean to one side due to the direction it was laid via the tension member being doubly wrapped in thereby increasing running stability.



Note 1: The degree to which a belt will lean to one side is greatly affected by the pulley alignment, and hence adjustment of the alignment is necessary with the SP specification.

Note 2: The SP specification is applicable to all flex-type belts but it cannot be used with some specific specifications. Please contact us in any case of this.

Note 3: The backside surface of the belt with a length of more than 1350 mm is fully ground down. (flat belts are excluded.) The back of the belt with a length of less than 1350 mm is partially ground down. Please consult us if fully ground down is necessary.

# Model and Type

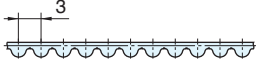
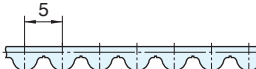
## Circular teethed MA belt

Type of teeth	Model	Shape	Pitch of teeth (mm)	Type			Page
				Flex	Joint	Linear	
Circular teethed belt	MA3		3	<input type="radio"/>		<input type="radio"/>	24
	MA5		5	<input type="radio"/>		<input type="radio"/>	26
	MA8		8	<input type="radio"/>		<input type="radio"/>	28

## Special trapezium teethed AT belt

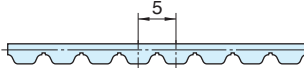
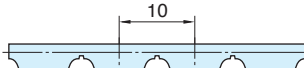
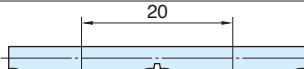
Special trapezium teethed belt	AT5		5	<input type="radio"/>	<input type="radio"/>	<input type="radio"/>	30
	AT10		10	<input type="radio"/>	<input type="radio"/>	<input type="radio"/>	32
	AT20		20	<input type="radio"/>		<input type="radio"/>	34

## Standard trapezium teethed belt

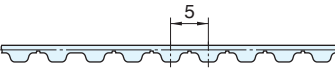
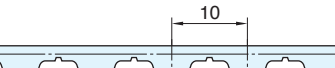
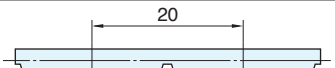
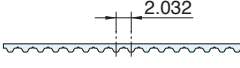
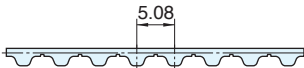
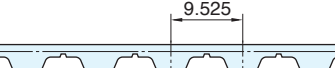
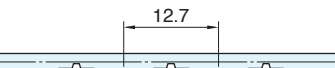
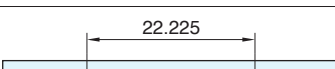
Trapezium teeth (meters)	T5		5	<input type="radio"/>	<input type="radio"/>	<input type="radio"/>	36
	T10		10	<input type="radio"/>	<input type="radio"/>	<input type="radio"/>	38
	T20		20	<input type="radio"/>	<input type="radio"/>	<input type="radio"/>	40
Trapezium teeth (inches)	MXL		2.032 (0.08inch)			<input type="radio"/>	42
	XL		5.08 (0.2inch)	<input type="radio"/>	<input type="radio"/>	<input type="radio"/>	44
	L		9.525 (0.375inch)	<input type="radio"/>	<input type="radio"/>	<input type="radio"/>	46
	H		12.7 (0.5inch)	<input type="radio"/>	<input type="radio"/>	<input type="radio"/>	48
	XH		22.225 (0.875inch)	<input type="radio"/>	<input type="radio"/>	<input type="radio"/>	50

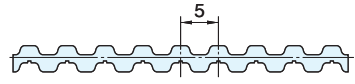
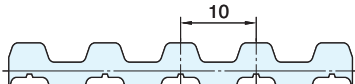
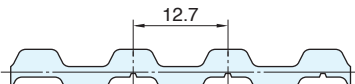

## Double sided belt equipped with trapezium teeth on both sides

Type of teeth	Model	Shape	Pitch of teeth (mm)	Type			Page
				Flex	Joint	Linear	
Double sided teathed belt	DT5		5	○			52
	DT10		10	○			53
	DH		12.7 (0.5inch)	○			54

## Self-tracking belt

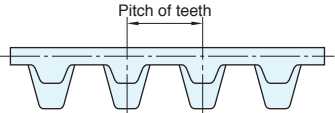
Self-tracking belt	MA5-V		5		○		55~59
	AT10-V		10		○		
	T5-V		5			○	
	T10-V		10			○	
	L-V		9.525			○	

\*The figure in the picture depicts the T10-V.

## Wide teathed belt

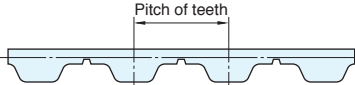
Wide teathed belt	Wide T10		10		○		60~61
	Wide H		12.7				

\*The figure in the picture depicts the T10.

## Flat belt

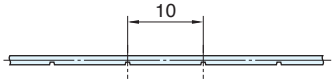
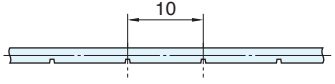
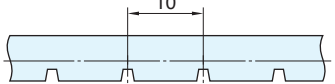
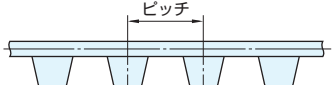
Flat belt	F12		—	○			62
	F20		—	○	○	○	63
	F60		—	○			64
Self-tracking flat belt	F10-V F20-V		—		○		65~66

## Double width toothed belts

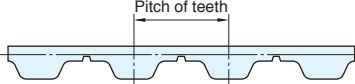
Double width teathed belts (Two belts heat-welded together side-by-side)	AT10		10	○	○		67~69
	T10		10				
	H		12.7				

\*The figure in the picture depicts the T10.

## Free attachment belt

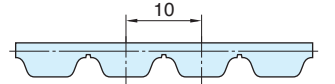
Free attachment belt	FAT1		10		○		70
----------------------	------	---	----	--	---	--	----

# Specifications

We can accommodate a wide range of applications with our full line-up of task-specific and customizable Iron Rubber belts which are changing trends in conveyance and power transmission.

## Rubber material

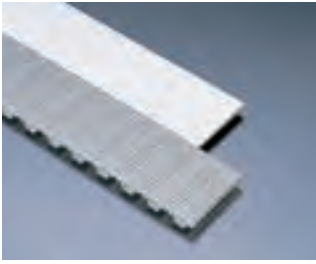

High-strength polyurethane rubber in translucent (A), white (E), and low-hardness translucent (D) is utilised as the rubber material. Also available in mildewproof and antimicrobial finishes (G). Please refer to pages 21 and 83 for more details.

## Tension member

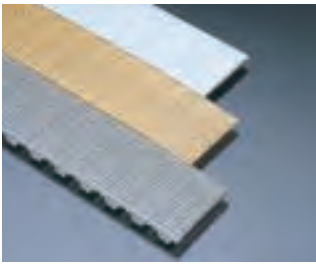

High-tensile steel cord, aramid fiber cord, and stainless steel cord are all available for use in the tension member.

Please refer to page 21 for more details.

## Trapezium teathed belt



Standard belt is equipped with trapezium teeth based on ISO standards.

## MA belt



MA belt is equipped with distinctive circular teeth. Circular teeth shape ensures smooth tracking. Superior positioning accuracy and almost zero backlash.

Please refer to pages 21 to 24 for more details.

## AT belt



High-torque and high-tensile type with enlarged tooth cross-section. Very little drop in performance and cord wear as the tips of the teeth of the belt engage the pulley. In combination with the backlash-less pulley improves the positioning accuracy. Please refer to pages 25 to 27 for more details.

## Double-sided teathed belts

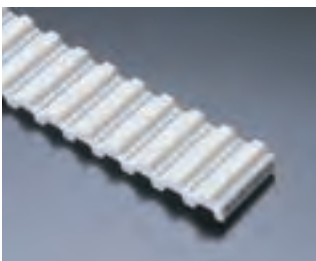

Double sided teathed belts is multi-shaft transferable due to the teeth being mounted on both sides.

Please refer to pages 36 to 38 for more details.

## Flat belt

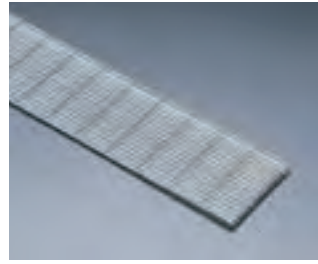

Easily maintained flat belt with minimal elongation due to steel cord being used as tension members.

Please refer to pages 46 to 48 for more details.

## Profiled belt



Weld-On profiles are thermally attached to the timing belt for an exceptionally strong bond. Profiles of varying standards are available.

Please refer to pages 56 to 74 for more details.

## One-piece molded profile belt



Highly accurate profile molded into the belt. (Requires a dedicated mold.)

## Tooth-side nylon faced belt

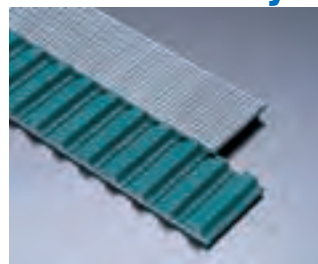

Toothed-side nylon faced belt has nylon integrated into the toothed face to reduce the coefficient of friction between the belt and the pulley. In addition the guide rail facilitates a decrease in noise and reduction in load.

## Back-side nylon faced belt

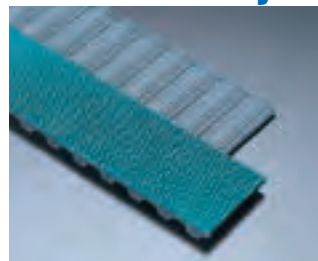

Backside nylon faced belt has nylon integrated into the backside to reduce the coefficient of friction between the belt and the transported article for accumulated transport. (Belt with back-side surface grain from just the nylon pattern are also available)

Joint type and Linear type only

## Both-side nylon faced belt

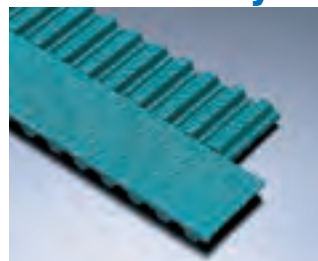

Both-side nylon faced belt has nylon integrated into both sides of the belt.

Joint type and Linear type only

## Wide belt

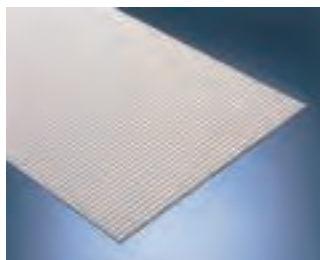

Wide belt is long & have widths of up to 400mm (T10).

Please refer to pages 44 to 45 for more details.

## Double width belt

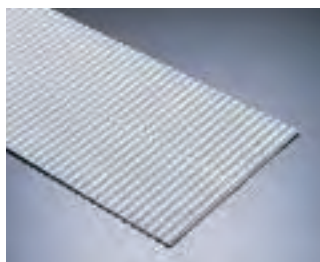

Double width belt has maximum widths of up to 800mm (T10). This is made possible though the heat-welding of two belts side-by-side.

Please refer to pages 51 to 53 for more details.

## Self-tracking belt

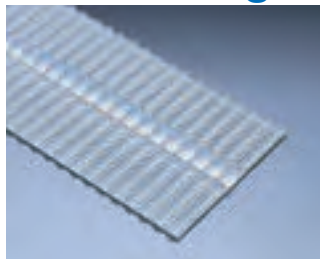

Self-tracking belt have self-tracking V-guides molded into the toothed surface. It is not necessary to attach a flange to the pulley.

Please refer to pages 39 to 43 for more details.

## Self-tracking flat belt

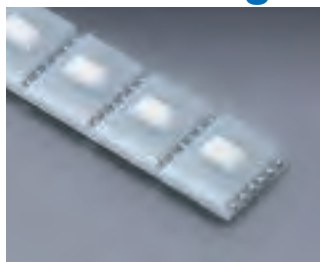

Self-tracking flat belt have V-guides integrated into the belt. It is suitable for light-weight conveyance of circuit boards etc. when used in a parallel configuration.

Please refer to pages 49 to 50 for more details.

## Lining belts



Lining belts has high friction coefficient rough lining. It is suitable for transporting on inclined angles due to slip prevention characteristics. It is soft-touch artificial leather lining. It is suitable for the transportation of easily damaged articles. It is a superior polyurethane form pad lining. It is suitable for sandwich belt conveyance and the protection of transported articles.

Please refer to page 75 for more details.

## High-friction nylon faced belt

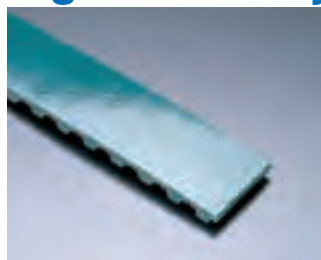

One-piece molded belt fabricated by coating the rear side of the belt with special urethane-impregnated fabric. Has a high friction coefficient and thus suits use with inclined angles. (Will become slippery if the belt gets contaminated with oil or dirt.) Please refer to page 21 for more details.

## Machined belts



Machined belts can be machined according to requirements in order to position the transported article etc. It is also possible to machine the toothed side as necessary to provide a guide function etc.

Please refer to page 75 for more details.

## Perforated belts



Perforated belts have perforations which can be machined into the belts as necessary for vacuum transportation or the fitting of attachments etc.

Please refer to page 75 for more details.

## FAT belt

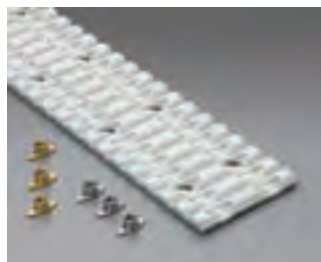

Can be used with secondary attachments with special nuts. The belt is equipped with spot-faced holes for use with the special nuts. Secondary attachment can be mounted using the holes in the pertinent positions.

Please refer to pages 54 to 55 for more details.

# Selection conditions and instructions

The belts (their design) can be selected according to calculations based on the power or transmission torque. The model and width of the belt can be determined using calculations. Please consult us for advice on selecting any additional specifications.

The selection process does not take into consideration external factors such as the environment, and hence you will need to confirm their compliance before use.

## 1. Necessary conditions for making a selection

- ① Power:  $P_0$  (kW); or transmission torque:  $M_{d0}$  (Nm)
- ② Pulley pitch circle diameter:  $d_p$  (mm)
- ③ Pulley rotation:  $n$  (rpm)
- ④ Belt rolling angle:  $\theta$  (°)
- ⑤ Number of idlers to the rear
- ⑥ Operating time per day
- ⑦ Number of starts/stops per day
- ⑧ Usage of the belt (power transmission or conveyor)

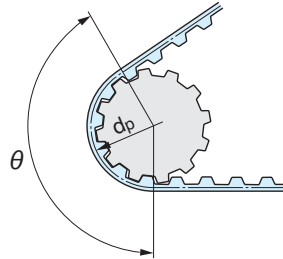

\*Please select the smallest pulley in the layout.

## 2. Selection instructions

### (1) Power and transmission torque

Use of the actual load of the power or transmission torque is the most ideal in making a selection; however, please use the maximum value of the motor in any calculation for the sake of safety.

### (2) For power transmission

Please use a flex type belt with power transmission.

### (3) Power transmission and linear drive (as described on page 86)

Please use a MA or AT belt.

\* Please ensure to use a belt lined with fabric on the tooth-side if the operating environment and usage allows it. (To reduce the friction coefficient between the belt and pulley)

Note that the belt needs to be at least 1.35 m long with flex type belts that are lined with fabric on the tooth-side.

	Pitch of teeth (mm)				
	3	5	8	10	20
<b>MA belt</b>	MA3	MA5	MA8	—	—
<b>AT belt</b>	—	AT5	—	AT10	AT20

### (4) Multiple belt configurations

If the load gets evenly distributed over belts placed in parallel then please divide the load by the number of belts and use that value in any calculations.

Please ensure to use the maximum load applicable to a single belt in any calculations if the possibility of an uneven load distribution exists.

### (5) Minimum number of pulley tooth

Please exercise caution as the minimum number of pulley tooth can vary depending on the belt model and speed of rotations. Please refer to page 78 for the minimum number of pulley tooth.

### (6) When using a backside idler

Please exercise caution as the minimum diameter of the backside idler can vary depending on the belt model.

Please refer to page 79 for the minimum diameter of the backside idler.

Please ensure to use a High-flex cord (flex type) with multi-shaft layouts such as roller conveyors.

### (7) When using a servo motor

Please select the belt according to the torque when a servo motor is used.

# Selection procedure

## Step 1 Determining the design power and design torque

Multiply the power/transmission torque by a correction coefficient (safety factor) when determining the design power/design torque.

[How to determine the design power/design torque]

- Design power:  $P = P_0 \times (1 + K_1 + K_2 + K_3 + K_4 + K_5)$
- Design torque:  $M_d = M_{d0} \times (1 + K_1 + K_2 + K_3 + K_4 + K_5)$

Correction coefficient for operating time (K1)

Operating time (time per day)	Correction coefficient
<8	0.0
8~16	0.2
16<	0.4

Correction coefficient for starts and stops (K2)

Number of starts and stops (times per day)	Correction coefficient
none	0.0
1~10	0.2
11~99	0.3
100~499	0.4
500≤	0.5

Correction coefficient for belt type (K3)

Belt type	Correction coefficient
Flex type	0.2
Liner type	0.5
Joint type	2.0

Correction coefficient for the backside idler (K4)

Number of backside idlers (pieces)	Correction coefficient
none	0.0
1	0.1
2	0.2
3	0.3
4	0.4
5 or more	0.5

\*Please perform the correction using the number of pulleys on the back side with double sided teethered belts.

Correction coefficient for the cord specification (K5)

Tension member specification	Correction coefficient
Steel cord, High-flex steel cord	0.0
Stainless-steel cord, High-flex stainless cord	0.2
Aramid fiber cord	0.0

- P: Design power (kW)
- P<sub>0</sub>: Power (kW)
- M<sub>d</sub>: Design torque (Nm)
- M<sub>d0</sub>: Transmission torque (Nm)

- K<sub>1</sub>: Correction coefficient for operating time
- K<sub>2</sub>: Correction coefficient for starts and stops
- K<sub>3</sub>: Correction coefficient for belt type
- K<sub>4</sub>: Correction coefficient for the backside idler
- K<sub>5</sub>: Correction coefficient for the cord specification

## Step 2 Deciding the belt model

Make the decision on the belt model to be used according to the simplified selection diagram provided on pages 18 and 19. To make a selection according to the power first decide the belt model according to the design power determined in Step 1 and the pulley rotations.

To make a selection according to the transmission torque first decide the belt model according to the design torque determined in Step 1 and the pulley rotations.

## Step 3 Deciding the number of pulley teeth

Decide the number of pulley teeth (z) corresponding to the belt model according to the usage conditions (pulley diameter).

\*Please pay attention to the minimum number of pulley tooth (see page 78).

- z: Number of pulley tooth
- Z<sub>E</sub>: Number of teeth in mesh

## Step 4 Determining the number of teeth in mesh: Z<sub>E</sub>

Determine the number of teeth in mesh (Z<sub>E</sub>) where the belt engages the pulley according to the number of pulleys (z) and the rolling angle (θ).

$$Z_E = z \times \frac{\theta}{360} \quad (\text{Round down to a whole number.})$$

Note that the number of mating teeth can be **up to 12**.

If the Z<sub>E</sub> determined using the above calculation is 13 teeth or more then please select the belt using "12 teeth", which is the upper limit.

## Step 5 Determining the belt width: bc

Determine the belt width using the most acceptable value provided on page 17.

To select using the design power (P):

$$bc = \frac{P \times 10^4}{P_s \times Z_E \times z} \times fw + fx$$

To select using the design torque (M<sub>d</sub>):

$$bc = \frac{M_d \times 10^3}{M_{ds} \times Z_E \times z} \times fw + fx$$

	fw	fx	Selected model
T5-V	1	6	T5-J(L)
T10-V	1.5	10	T10-J(L)
AT10-V	1	10	AT10-J(L)
MA5-V	1	7	MA5-L
L-V	1	15.4	L-J
150-T10-J	1.5	0	T10-J
400-T10-J	3.5	0	T10-J
600-H-J	1.5	0	H-J
FAT1-J	2.5	0	AT10-J
Other	1	0	—

- bc: Belt width
- P<sub>s</sub>: Allowable power
- M<sub>ds</sub>: Acceptable transmission torque
- fw, fx: Coefficient of the width

# Example of selection

## Case 1 To select using the power (kW)

Necessary conditions for selecting:	•Power:	$P_0=10\text{kW}$
	•Driving pulley diameter:	$d \approx \varnothing 80$
	•Number of driving pulley rotations:	$n_1=2000\text{rpm}$ (Deceleration rate of 1: 2)
	•Belt rolling angle:	$\theta = 175^\circ$
	•Distance between shafts:	$C=900\text{mm}$
	•With or without backside idler:	0 piece
	•Operating time per day:	10 hours
	•Number of starts and stops per day:	none
	•Usage:	Power transmission

### Step 1 Determining the design power

Determine the design power according to the power and correction coefficient.

The usage is power transmission and hence the flex type (steel cord) is used and the calculation made as follows.

$$P = P_0 \times (1 + K_1 + K_2 + K_3 + K_4 + K_5) \\ = 10 \times (1 + 0.2 + 0.0 + 0.2 + 0.0 + 0.0) = 14 \text{ kW}$$

### Step 2 Deciding the belt model

The selection is made according to the power and hence the Belt selection diagram 1 should be used.

The decision is made to use the AT10 because the design power is 14 kW,

the pulley diameter approximately 80 mm, and the number of pulley rotations 2000 rpm.

(As the usage concerns power transmission ensure to select a MA and AT belt.)

### Step 3 Deciding the number of pulley teeth

The driving pulley diameter,  $d$ , is approximately  $\varnothing 80$ , and hence the decision is made to that the number of driving pulley teeth is 25.

$$(d_{p1} = 79.58 \quad d_{o1} = 77.70)$$

The deceleration rate is 1:2, and hence the decision is made that the number of driven pulley teeth is 50.

$$(d_{p2} = 159.15 \quad d_{o2} = 157.30)$$

### Step 4 Determining the number of teeth in mesh: $Z_E$

Determine the number of teeth in mesh in accordance with

$$Z_E = z_1 \times \frac{\theta}{360} \qquad Z_E = z_1 \times \frac{\theta}{360} = 25 \times \frac{175}{360} \\ = 12.2$$

The upper limit of the mating teeth is 12 and hence the  $Z_E$  is 12.

### Step 5 Determining the belt width

Determine the belt width using a belt width calculation and according to

$$bc = \frac{P \times 10^4}{P_s \times Z_E \times z_1} \times fw + fx \qquad bc = \frac{P \times 10^4}{P_s \times Z_E \times z_1} \times fw + fx = \frac{14 \times 10^4}{10.46 \times 12 \times 25} \times 1 + 0 = 44.6 \text{ mm} \rightarrow 50 \text{ mm}$$

(Pinpoint the  $P_s$  using the acceptable value on page 17.)

As described above the belt selected would be the

**050-AT10-○○○○E-F**

\*Please ensure to use a belt lined with fabric on the teeth-side if the operating environment and usage allows it (-F1).

## Case 2 To select using the torque (Nm)

Necessary conditions for selecting:	•Torque:	$Md_0=400\text{Nm}$
	•Driving pulley diameter:	$d \approx \varnothing 160$
	•Number of driving pulley rotations:	$n_1=200\text{rpm}$
	•Belt rolling angle:	$\theta = 180^\circ$
	•Distance between shafts:	$C=800\text{mm}$
	•With or without backside idler:	none
	•Operating time per day:	6 hours
	•Number of starts and stops per day:	approximately 300 times
	•Usage:	Power transmission (include the possibility of it getting wet)

### Step 1 Determining the design torque

Determine the design torque using the torque and correction coefficient.

The usage is power transmission and the possibility of it getting wet exists and hence flex type (stainless-steel cord) should be used and the calculation made as follows.

$$\begin{aligned} Md &= Md_0 \times (1+K_1+K_2+K_3+K_4+K_5) \\ &= 400 \times (1+0.0+0.4+0.2+0.0+0.2) = 720 \text{ Nm} \end{aligned}$$

### Step 2 Deciding the belt model

The selection is made according to the torque and hence Belt selection diagram 2 is used.

The decision is made to use an AT20 because the design torque is 720 Nm, the pulley diameter approximately 160 mm, and the number of pulley rotations 200 rpm.

(The usage is power transmission and hence a MA or AT belt should be used.)

### Step 3 Deciding the number of pulley teeth

The driving pulley diameter,  $d$ , is approximately  $\varnothing 160$ , and hence the decision is made to that the number of driving pulley teeth is 25.

$$(d_p = 159.15 \quad d_o = 156.30)$$

### Step 4 Determining the number of teeth in mesh: $Z_E$

Determine the number of teeth in mesh in accordance with

$$\begin{aligned} Z_E &= z \times \frac{\theta}{360} \\ Z_E &= z \times \frac{\theta}{360} = 25 \times \frac{180}{360} \\ &= 12.5 \end{aligned}$$

The upper limit of the mating teeth is 12 and hence the  $Z_E$  is 12.

### Step 5 Determining the belt width

Determine the belt width using a belt width calculation and according to

$$bc = \frac{Md \times 10^3}{Mds \times Z_E \times z} \times fw + fx \quad bc = \frac{Md \times 10^3}{Mds \times Z_E \times z} \times fw + fx = \frac{720 \times 10^3}{34.8 \times 12 \times 25} \times 1 + 0 = 69.0 \text{ mm} \rightarrow 75 \text{ mm}$$

(Pinpoint the  $Mds$  using the acceptable value on page 17.)

As described above the belt selected would be the

**075-AT20-○○○○E-FS**

\*Please ensure to use a belt lined with fabric on the teeth-side if the operating environment and usage allows it (-FS1).

# Example of selection

## Case 3 To select using the weight of goods conveyed (Nm)

Necessary conditions for selecting:

•Power/torque:	Not yet clarified because the motor specification has not been decided	•With or without backside idler: none
•Driving pulley :	$d \doteq$ approximately $\varnothing 95$	•Operating time per day: 18 hours
•Belt rolling angle:	$\theta = 180^\circ$	•Number of starts and stops: 1 time/3 s
•Belt speed:	$V = 0.3\text{m/s}$	•Work: $m = 18\text{ kg/piece} \times 10\text{ pieces}$
•Distance between shafts: $C = 5000\text{mm}$		•Guide rail material: SUS (to the belt: $\mu = 0.6$ ) conveyor
		•Usage:

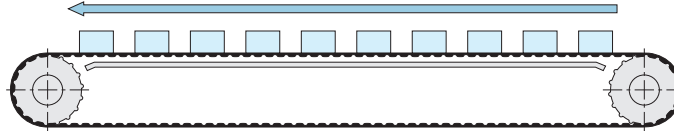

### Step 1 Determining the torque

(1) Determine the effective tension

$$(1) U = \mu \times m \times g$$

(2) Determine the number of pulley rotations using the following formula.

$$= 0.6 \times (18 \times 10) \times 9.8 = 1058 \text{ N}$$

$$n = \frac{19.1 \times 10^3 \times V}{d_p}$$

$$(2) n = \frac{19.1 \times 10^3 \times V}{d_p} \quad (\text{Tentative use of } \varnothing 95 \text{ for the } d_p.)$$

(3) Convert the effective tension into torque using the following formula.

$$= \frac{19.1 \times 10^3 \times 0.3}{95} = 60 \text{ rpm}$$

$$M_{d0} = \frac{U \times d_p}{2 \times 10^3}$$

$$(3) M_{d0} = \frac{U \times d_p}{2 \times 10^3} = \frac{1058 \times 95}{2 \times 10^3} = 50.3 \text{ Nm}$$

### Step 2 Determining the design torque

Determine the design torque according to the torque determined in Step 1 and the correction coefficient. The usage will be a conveyor and hence a joint type (steel cord) is used and the calculation made as follows. (\*Supports use of the flex type.)

$$M_d = M_{d0} \times (1 + K_1 + K_2 + K_3 + K_4 + K_5) \\ = 50.3 \times (1 + 0.4 + 0.5 + 2.0 + 0.0 + 0.0) = 196 \text{ Nm}$$

### Step 3 Deciding the belt model

The selection is made according to the torque and hence Belt selection diagram 2 is used. The decision is made to use an T10 because the design torque is 196 Nm, the pulley diameter approximately 95 mm, and the number of pulley rotations 60 rpm. (AT10 or H both available.)

### Step 4 Deciding the number of pulley teeth

The driving pulley diameter,  $d$ , is approximately  $\varnothing 95$ , and hence the decision is made to that the number of driving pulley teeth is 30.

$$(d_p = 95.49 \quad d_o = 93.65)$$

### Step 5 Determining the number of teeth in mesh: $Z_E$

Determine the number of teeth in mesh in accordance with

$$Z_E = z \times \frac{\theta}{360}$$

$$Z_E = z \times \frac{\theta}{360} = 30 \times \frac{180}{360} = 15$$

= pulley teeth is 15 (The upper limit of the mating teeth is 12 and hence the  $Z_E$  is 12.)

### Step 6 Determining the belt width

Determine the belt width using a belt width calculation and according to

$$bc = \frac{M_d \times 10^3}{M_{ds} \times Z_E \times z} \times fw + fx$$

$$bc = \frac{M_d \times 10^3}{M_{ds} \times Z_E \times z} \times fw + fx = \frac{196 \times 10^3}{8.14 \times 12 \times 30} \times 1 + 0 = 66.9 \text{ mm} \rightarrow 75 \text{ mm}$$

(Pinpoint the  $M_{ds}$  using the acceptable value on page 17.)

As described above the belt selected would be the

**075-T10-○○○○A-J**

\*The use of a belt lined with fabric on the teeth-side (-J1) is recommended in thereby reducing the friction coefficient between the belt and the guide.

\*After deciding the motor specifications please then reselect the belt.



# Case 4 Selection with operations that involve sudden acceleration or stops

Necessary conditions for selecting:

- Power/torque: not yet clarified because the motor specification has not been decided
- Driving pulley diameter:  $d \doteq \varnothing 200$
- Belt speed:  $V = 1 \text{ m/s}$
- Acceleration (deceleration) time:  $T = 0.2 \text{ s}$
- Distance between shafts:  $C = 5000 \text{ mm}$
- With or without backside idler: none
- Operating time per day: 12 hours
- Number of starts and stops per day: approximately 5000 times
- Work:  $m = 200 \text{ kg}$
- Work instruction: linear guide ( $\mu = 0.1$ )
- Usage: reciprocation of the work via a linear drive (horizontal)

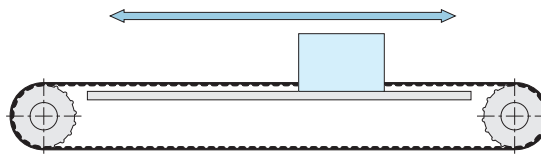
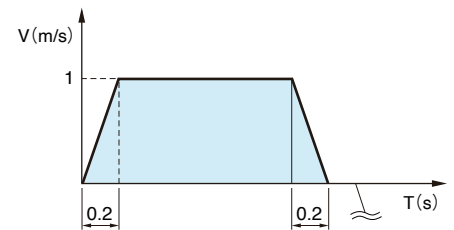

## Step 1 Determining the number of pulley rotations

Determine the number of pulley rotations according to

$$n = \frac{19.1 \times 10^3 \times V}{dp}$$

$$n = \frac{19.1 \times 10^3 \times V}{dp} = \frac{19.1 \times 10^3 \times 1}{200} \doteq 96 \text{ rpm}$$

## Step 2 Determining the sliding torque

(1) Determine the sliding resistance.

$$F = \mu \times m \times g$$

$$(1) F = \mu \times m \times g = 0.1 \times 200 \times 9.8 = 196 \text{ N}$$

(2) Convert the sliding resistance into torque using the following formula.

$$Md_A = \frac{F \times dp}{2 \times 10^3}$$

$$(2) Md_A = \frac{F \times dp}{2 \times 10^3} = \frac{196 \times 200}{2 \times 10^3} = 19.6 \text{ Nm}$$

## Step 3 Determining the inertia moment

(1) Determine the inertia moment of the rotor (such as driven pulley) according to

$$J_1 = \frac{m \times D^2}{8 \times 10^6}$$

$$(1) J_1 = \frac{m \times D^2}{8 \times 10^6} = \frac{8.8 \times 200^2}{8 \times 10^6} = 44 \times 10^{-3} \text{ kgm}^2$$

(2) Determine the inertia moment of the object moving horizontally according to

$$J_2 = \frac{m \times D^2}{4 \times 10^6}$$

$$(2) J_2 = \frac{m \times D^2}{4 \times 10^6} = \frac{200 \times 200^2}{4 \times 10^6} = 2.00 \text{ kgm}^2$$

(3) Determine the total of J.

$$(3) \Sigma J = J_1 + J_2 = 44 \times 10^{-3} + 2.00 = 2.04 \text{ kgm}^2$$

Calculate with the specific gravity 2.8 of the aluminum after assuming the pulley mass (do) to be 200 and W to be 100.

$$m = \frac{\left(\frac{d}{2}\right)^2 \times \pi \times W}{10^6} \times \gamma = \frac{\left(\frac{200}{2}\right)^2 \times \pi \times 100}{10^6} \times 2.8 = 8.8 \text{ kg}$$

## Step 4 Determining the acceleration torque

Determine the acceleration torque according to

$$Md_B = \frac{J \times \Delta n}{9.55 \times T}$$

$$Md_B = \frac{J \times \Delta n}{9.55 \times T} = \frac{2.04 \times (96 - 0)}{9.55 \times 0.2} = 103 \text{ Nm}$$

## Step 5 Determining the torque

Calculate the total of sliding torque and acceleration torque to determine the torque ( $Md_0$ ).

$$Md_0 = Md_A + Md_B = 19.6 + 103 = 123 \text{ Nm}$$

Continue the calculation after referring to Case 2 on page 13.

\*After deciding the motor specifications please then reselect the belt.

# List of formulas

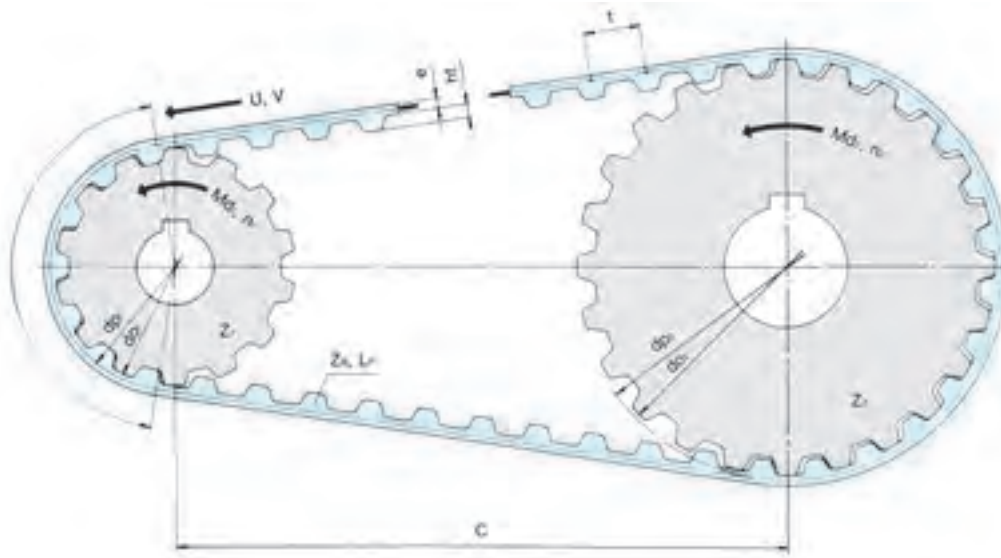

- LP: belt length (mm)
- ZB: number of belt teeth
- t: belt tooth pitch (mm)
- ht: belt tooth height (mm)
- e: belt back thickness (mm)
- b: belt width (mm)
- ZE: number of teeth in mesh
- C: distance between shafts (mm)
- z1: number of pulley teeth
- z2: number of pulley teeth
- dp1: pulley pitch circle diameter (mm)
- dp2: pulley pitch circle diameter (mm)
- i: Pulley teeth ratio (z1/z2)
- do1: pulley tooth tip circle diameter (mm)
- do2: pulley tooth tip circle diameter (mm)
- n1: number of pulley rotations (rpm)
- n2: number of pulley rotations (rpm)
- P0: power (kW)
- Md0: torque (Nm)
- U: effective tension (N)
- MdB: acceleration torque (Nm)
- T: acceleration time (s)
- J: inertia moment (kgm<sup>2</sup>)
- V: speed (m/s)
- ω: Angular speed (s<sup>-1</sup>)
- m: mass (kg)

Belt length (of two shafts)	LP	$i \neq 1$ $LP \div \frac{\pi}{2} (dp_1 + dp_2) + 2C + \frac{(dp_2 - dp_1)^2}{4C}$	$i = 1$ $LP = 2C + z \times t$
Power	P0	$P_0 = \frac{Md \times n}{9.55 \times 10^3}$	$P_0 = \frac{U \times dp \times n}{19.1 \times 10^6}$
Torque	Md0	$Md_0 = \frac{U \times dp}{2 \times 10^3}$	$Md_0 = \frac{9.55 \times 10^3 \times P}{n}$
Effective tension	U	$U = \frac{2 \times 10^3 \times Md}{dp}$	$U = \frac{19.1 \times 10^6 \times P}{n \times dp}$
Speed of rotations	n	$n = \frac{19.1 \times 10^3 \times V}{dp}$	
Belt speed	V	$V = \frac{dp \times n}{19.1 \times 10^3}$	
Angular speed	ω	$\omega = \frac{\pi \times n}{30}$	
Inertia moment J øD, ød: mm m: kg	Solid cylinder	$J = \frac{m \times D^2}{8 \times 10^6}$	Hollow cylinder $J = \frac{m \times (D^2 + d^2)}{8 \times 10^6}$
	Object moving horizontally	$J = \frac{m \times D^2}{4 \times 10^6}$	
Acceleration torque	MdB	$MdB = \frac{J \times \Delta P}{9.55 \times T}$	

## Conversion (engineering unit → SI unit)

Force	1 kgf = 9.807 N
Torque	1 kgf · m = 9.807 Nm
Power	1 HP = 0.746 kW
Inertia moment	1 kgf · m <sup>2</sup> = 4 kg · m <sup>2</sup>

## Specific gravity (for reference)

Aluminum	2.8
Steel	7.8
Stainless-steel	7.8

# Acceptable value

## Allowable power: Ps

Pulley rotations n1 (rpm)	MA3	MA5	MA8	AT5	AT10	AT20	T5	T10	T20	MXL	XL	L	H	XH
0	0	0	0	0	0	0	0	0	0	0	0	0	0	0
20	0.026	0.052	0.181	0.052	0.226	0.954	0.043	0.181	0.734	0.007	0.044	0.129	0.206	1.021
40	0.050	0.101	0.351	0.101	0.439	1.847	0.084	0.351	1.421	0.014	0.085	0.250	0.401	1.975
60	0.074	0.147	0.511	0.147	0.639	2.68	0.123	0.511	2.06	0.020	0.124	0.364	0.583	2.86
80	0.096	0.192	0.661	0.192	0.826	3.45	0.160	0.661	2.66	0.026	0.161	0.471	0.753	3.69
100	0.116	0.233	0.800	0.233	1.000	4.17	0.194	0.800	3.21	0.032	0.196	0.572	0.910	4.45
200	0.211	0.422	1.423	0.422	1.779	7.29	0.351	1.423	5.61	0.058	0.354	1.019	1.616	7.78
300	0.296	0.592	1.984	0.592	2.48	10.03	0.494	1.980	7.71	0.082	0.498	1.419	2.25	10.50
400	0.376	0.753	2.496	0.753	3.12	12.50	0.627	2.49	9.62	0.104	0.632	1.789	2.83	13.32
500	0.452	0.905	2.976	0.905	3.72	14.80	0.754	2.98	11.38	0.126	0.760	2.14	3.37	15.75
600	0.525	1.050	3.432	1.050	4.29	16.94	0.875	3.43	13.03	0.147	0.881	2.47	3.88	18.02
700	0.593	1.187	3.864	1.187	4.83	18.95	0.989	3.87	14.58	0.168	0.999	2.78	4.37	20.2
800	0.662	1.324	4.280	1.324	5.35	20.9	1.104	4.28	16.05	0.188	1.113	3.08	4.83	22.2
900	0.728	1.456	4.664	1.456	5.83	22.7	1.213	4.68	17.44	0.208	1.223	3.37	5.28	24.1
1000	0.791	1.578	5.064	1.578	6.33	24.4	1.319	5.07	18.77	0.227	1.330	3.65	5.72	25.9
1100	0.854	1.708	5.440	1.708	6.80	26.1	1.423	5.44	20.0	0.247	1.434	3.92	6.13	27.7
1200	0.914	1.829	5.800	1.829	7.25	27.6	1.524	5.80	21.3	0.266	1.536	4.19	6.54	29.4
1300	0.974	1.947	6.152	1.947	7.69	29.2	1.623	6.15	22.4	0.285	1.636	4.44	6.93	31.0
1400	1.031	2.06	6.496	2.06	8.12	30.6	1.719	6.49	23.6	0.303	1.733	4.69	7.31	32.5
1500	1.088	2.18	6.824	2.18	8.53	32.0	1.814	6.83	24.6	0.322	1.829	4.93	7.68	34.0
1600	1.144	2.29	7.152	2.29	8.94	33.4	1.907	7.15	25.7	0.340	1.923	5.17	8.04	35.4
1700	1.199	2.40	7.464	2.40	9.33	34.7	1.998	7.46	26.7	0.358	2.01	5.40	8.39	36.8
1800	1.254	2.51	7.776	2.51	9.72	36.0	2.09	7.77	27.7	0.378	2.11	5.62	8.73	38.2
1900	1.308	2.61	8.072	2.61	10.09	37.2	2.18	8.07	28.6	0.394	2.19	5.84	9.06	39.5
2000	1.356	2.72	8.368	2.72	10.46	38.4	2.26	8.37	29.5	0.413	2.28	6.06	9.39	40.7
2200	1.458	2.92	8.936	2.92	11.17	40.7	2.43	8.94	31.3	0.448	2.45	6.48	10.02	43.1
2400	1.560	3.12	9.480	3.12	11.85	42.8	2.60	9.48	32.9	0.485	2.62	6.88	10.63	45.3
2600	1.656	3.31	10.008	3.31	12.51	44.8	2.76	10.01	34.5	0.520	2.78	7.27	11.21	47.4
2800	1.746	3.49	10.512	3.49	13.14	46.7	2.91	10.51	35.9	0.556	2.94	7.64	11.76	49.4
3000	1.838	3.68	11.000	3.68	13.75	48.5	3.06	11.00	37.3	0.590	3.09	8.00	12.30	51.3

Selecting a belt

## Acceptable transmission torque: Mds

Pulley rotations n1 (rpm)	MA3	MA5	MA8	AT5	AT10	AT20	T5	T10	T20	MXL	XL	L	H	XH
0	1.26	2.52	8.888	2.52	11.11	47.0	2.10	8.89	36.1	0.344	2.13	6.31	10.15	50.3
20	1.23	2.46	8.640	2.46	10.80	45.5	2.05	8.64	35.0	0.339	2.08	6.14	9.86	48.7
40	1.20	2.40	8.392	2.40	10.49	44.0	2.00	8.39	33.9	0.328	2.03	5.97	9.56	47.2
60	1.173	2.35	8.136	2.35	10.17	42.7	1.955	8.14	32.8	0.319	1.976	5.80	9.27	45.6
80	1.144	2.29	7.888	2.29	9.86	41.2	1.906	7.89	31.7	0.311	1.923	5.63	8.98	44.0
100	1.114	2.23	7.640	2.23	9.55	39.8	1.857	7.64	30.6	0.303	1.871	5.46	8.69	42.4
200	1.006	2.01	6.800	2.01	8.50	34.8	1.677	6.80	26.8	0.276	1.690	4.86	7.72	37.1
300	0.943	1.887	6.304	1.887	7.88	31.9	1.572	6.30	24.6	0.260	1.584	4.52	7.15	34.0
400	0.898	1.797	5.952	1.797	7.44	29.9	1.497	5.95	23.0	0.249	1.509	4.27	6.74	31.8
500	0.864	1.728	5.680	1.728	7.10	28.3	1.440	5.68	21.7	0.241	1.451	4.08	6.43	30.1
600	0.836	1.671	5.456	1.671	6.82	27.0	1.393	5.46	20.7	0.234	1.403	3.92	6.18	28.7
700	0.811	1.623	5.272	1.623	6.59	25.9	1.352	5.27	19.89	0.229	1.363	3.79	5.96	27.5
800	0.791	1.581	5.112	1.581	6.39	24.9	1.318	5.11	19.15	0.225	1.328	3.68	5.77	26.5
900	0.772	1.545	4.968	1.545	6.21	24.1	1.287	4.97	18.50	0.221	1.298	3.58	5.61	25.6
1000	0.756	1.512	4.840	1.512	6.05	23.3	1.260	4.84	17.92	0.217	1.270	3.49	5.46	24.8
1100	0.741	1.482	4.720	1.482	5.90	22.6	1.235	4.72	17.40	0.214	1.245	3.41	5.32	24.0
1200	0.728	1.456	4.616	1.456	5.77	22.0	1.213	4.62	16.92	0.211	1.223	3.33	5.20	23.4
1300	0.715	1.430	4.520	1.430	5.65	21.4	1.192	4.52	16.48	0.209	1.202	3.26	5.09	22.7
1400	0.704	1.407	4.432	1.407	5.54	20.9	1.173	4.43	16.07	0.207	1.182	3.20	4.98	22.2
1500	0.693	1.386	4.344	1.386	5.43	20.4	1.155	4.35	15.69	0.205	1.164	3.14	4.89	21.6
1600	0.683	1.366	4.264	1.366	5.33	19.93	1.138	4.27	15.33	0.203	1.148	3.08	4.80	21.2
1700	0.673	1.347	4.192	1.347	5.24	19.50	1.122	4.19	15.00	0.201	1.132	3.03	4.71	20.7
1800	0.665	1.329	4.120	1.329	5.15	19.09	1.108	4.12	14.69	0.200	1.117	2.98	4.63	20.2
1900	0.656	1.312	4.056	1.312	5.07	18.70	1.094	4.06	14.39	0.198	1.103	2.94	4.56	19.83
2000	0.648	1.296	3.952	1.296	4.94	18.34	1.080	4.00	14.11	0.197	1.089	2.89	4.48	19.44
2200	0.634	1.267	3.880	1.267	4.85	17.65	1.056	3.88	13.58	0.195	1.065	2.81	4.35	18.70
2400	0.620	1.240	3.776	1.240	4.72	17.03	1.033	3.77	13.10	0.193	1.042	2.74	4.23	18.04
2600	0.607	1.215	3.672	1.215	4.59	16.64	1.012	3.68	12.66	0.191	1.021	2.67	4.12	17.42
2800	0.596	1.192	3.584	1.192	4.48	15.93	0.993	3.59	12.26	0.190	1.002	2.61	4.01	16.85
3000	0.585	1.170	3.504	1.170	4.38	15.43	0.975	3.50	11.87	0.188	0.984	2.55	3.91	16.32

# Diagram of simple version of the belt

## Selection diagram 1: Simple selection according to power

Select the belt model according to  $\frac{\text{Design power (P)} \times 10^3}{\text{Pulley diameter (d)}}$  and the number of pulley rotations (n).

### Selection diagram 1-1. MA belt

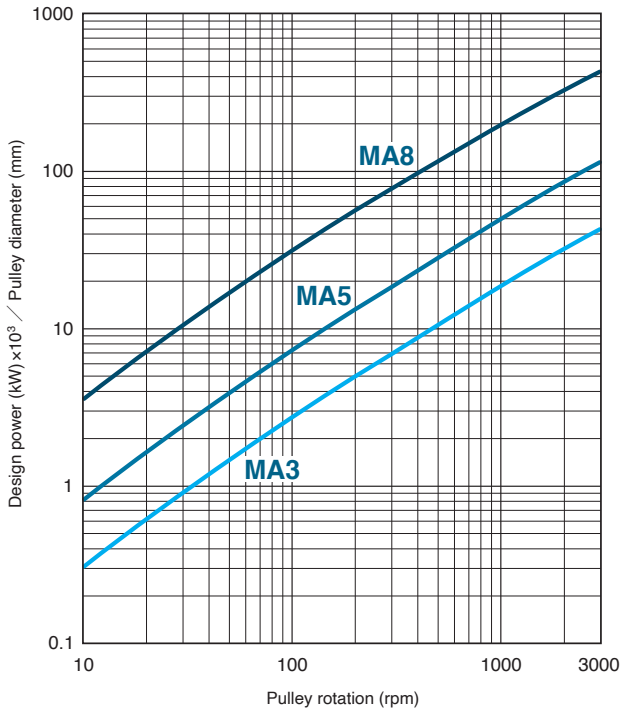

### Selection diagram 1-2. AT belt

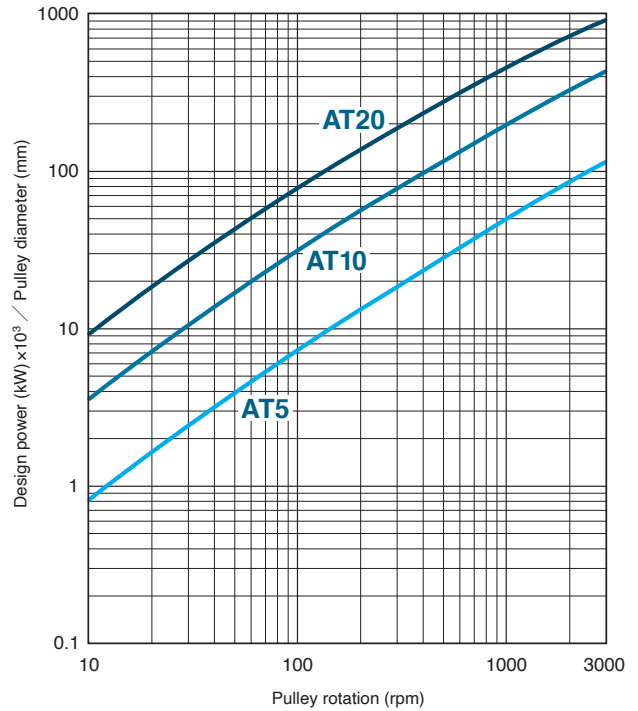

### Selection diagram 1-3. In meters belt

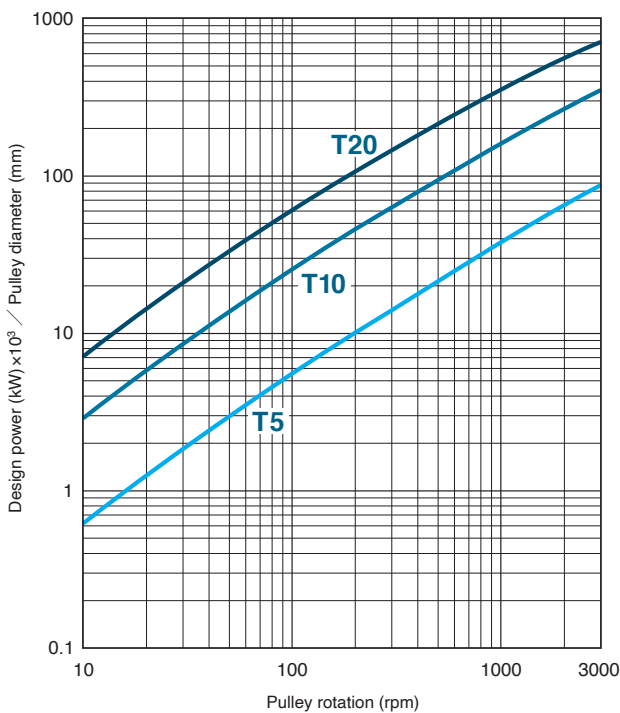

### Selection diagram 1-4. In inches belt

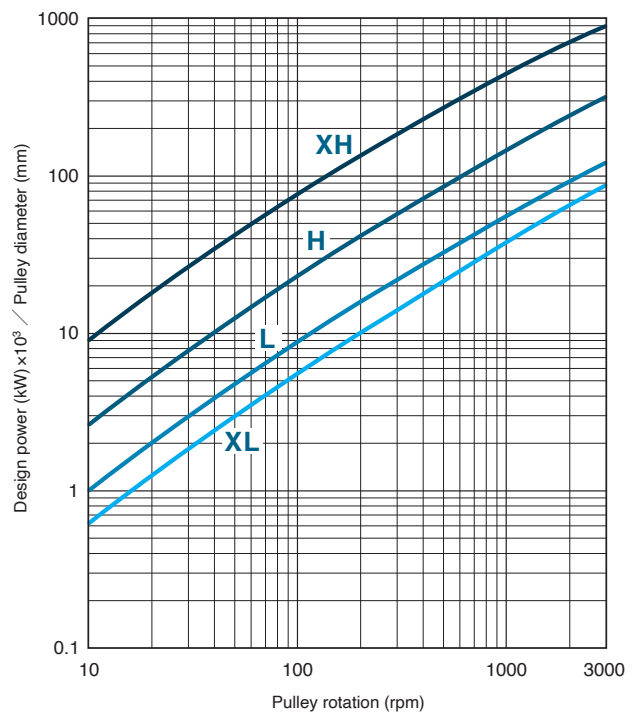

## Selection diagram 2: Simple selection according to the torque

Select the belt model according to  $\frac{\text{Design torque (Md)}}{\text{Pulley diameter (d)}}$  and the number of pulley rotations (n).

### Selection diagram 2-1. MA belt

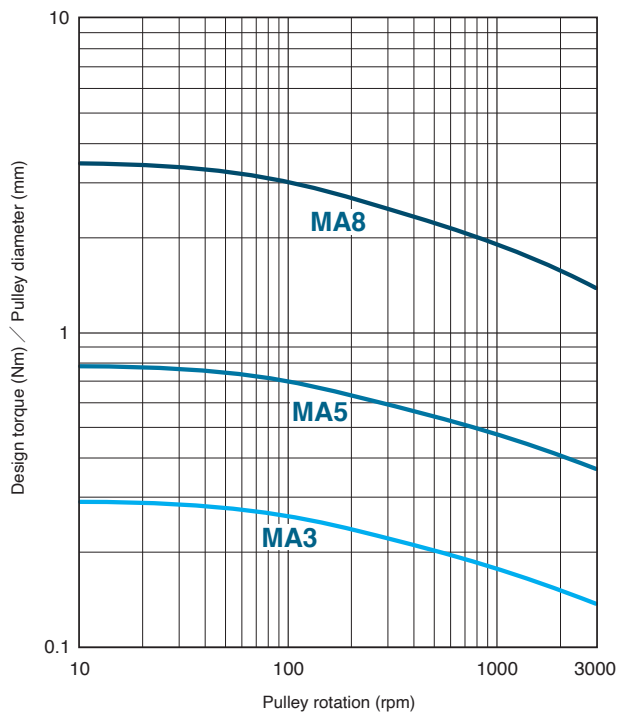

### Selection diagram 2-2. AT belt

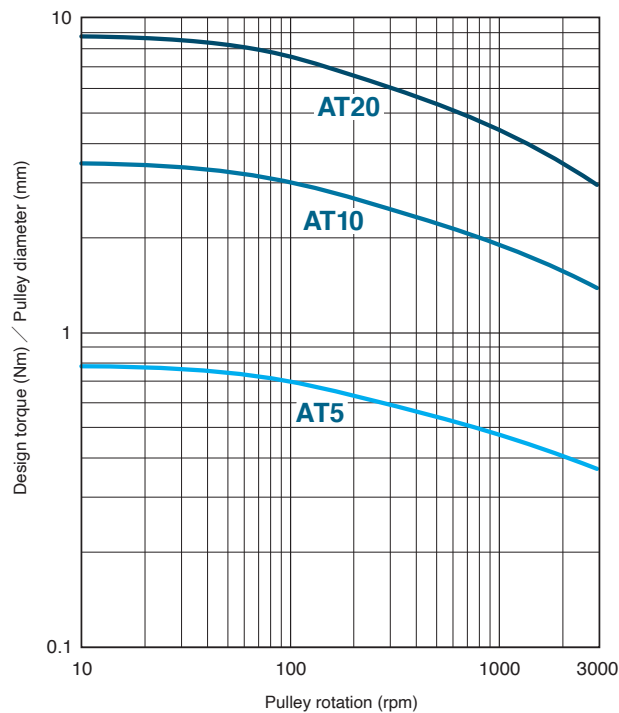

### Selection diagram 2-3. In meters belt

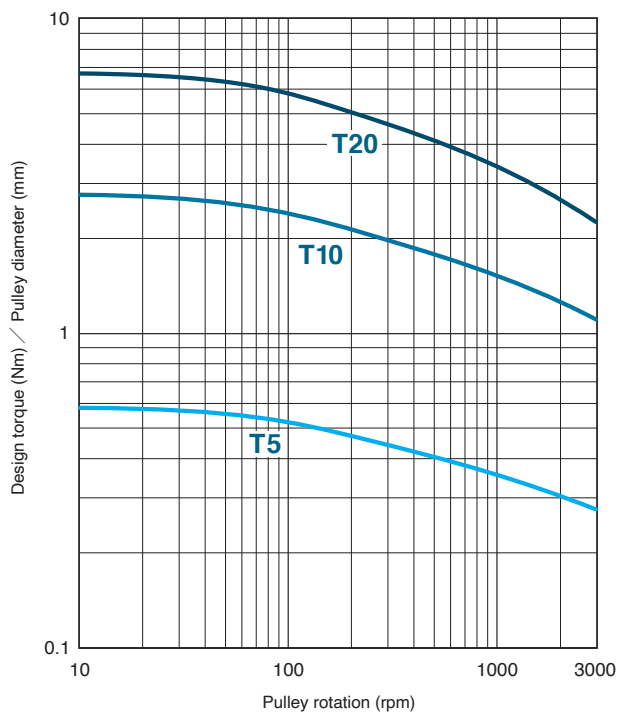

### Selection diagram 2-4. In inches belt

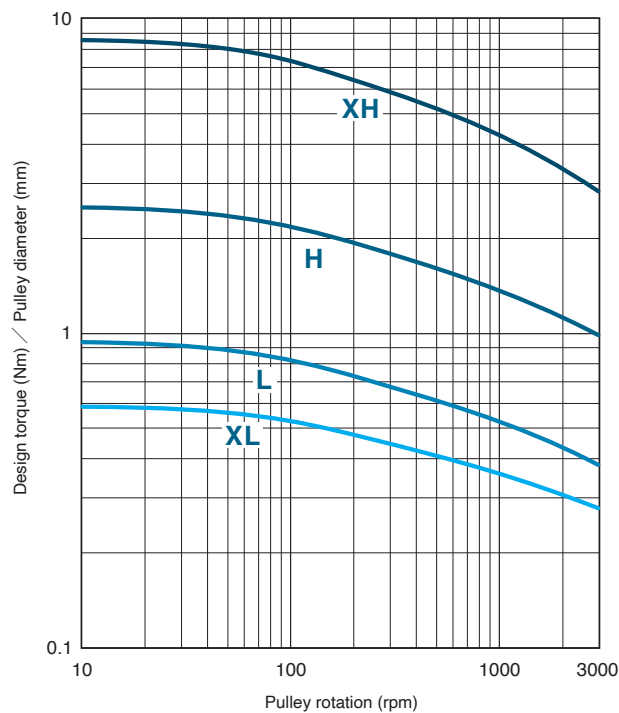

# Method used to select the dimensions of Iron Rubber Belt models

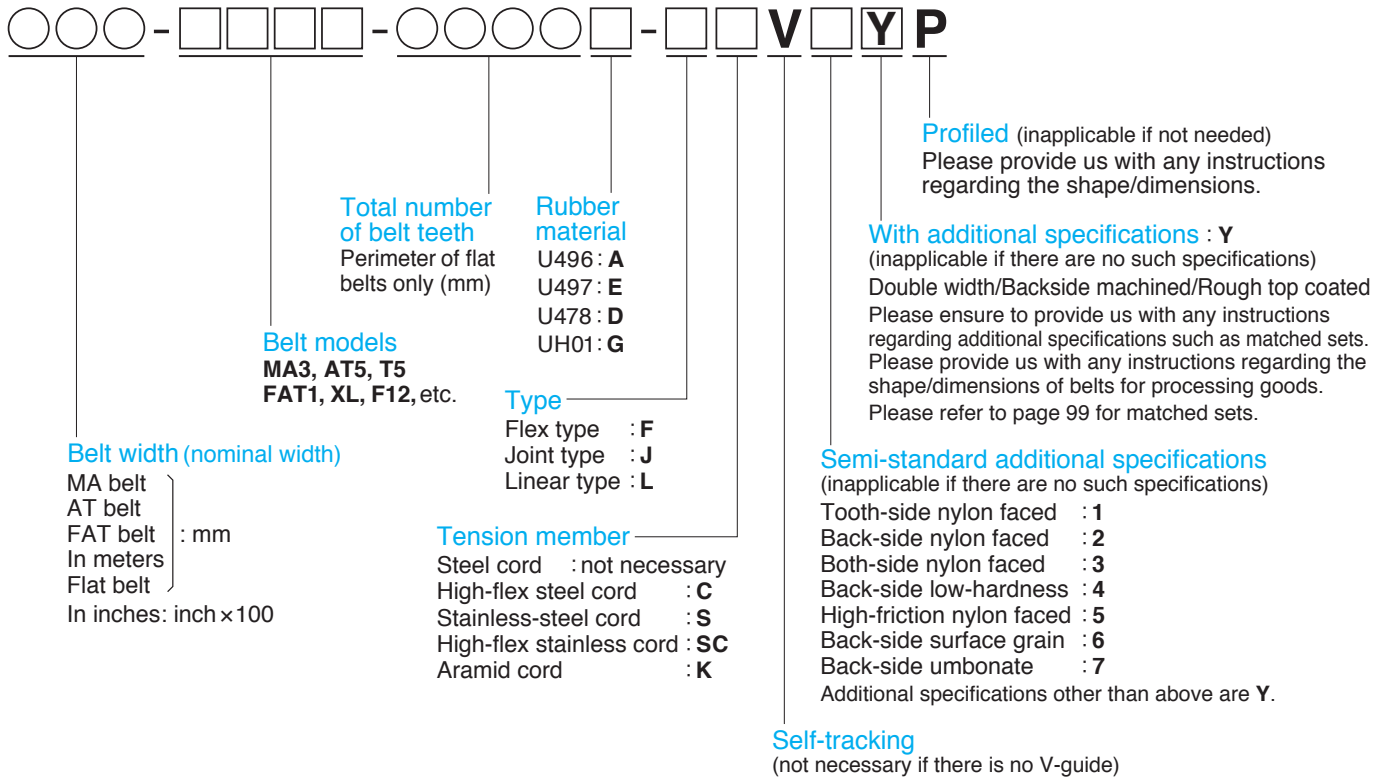

## Example and specifications

### 025-T5-0369A-J3

Belt width	: 25 mm
Belt model	: T5 (pitch: 5 mm)
Number of belt teeth	: 369 teeth (perimeter: 1845 mm)
Rubber material	: A (U496)
Type	: Joint type
Cord specification	: Steel cord
V-guide	: none
Semi-standard additional specifications	: Both-side nylon faced
Additional specifications	: none
Profiled	: none

### 100-T10-0432A-J2Y

Belt width	: 100 mm
Belt model	: T10 (pitch: 10 mm)
Number of belt teeth	: 432 teeth (perimeter: 4320 mm)
Rubber material	: A (U496)
Type	: Joint type
Cord specification	: Steel cord
V-guide	: none
Semi-standard additional specifications	: Back-side nylon faced
Additional specifications	: Toothed side machined
Profiled	: none

### 050-AT10-0321E-FS1P

Belt width	: 50 mm
Belt model	: AT10 (pitch: 10 mm)
Number of belt teeth	: 321 teeth (perimeter: 3210 mm)
Rubber material	: E (U497)
Type	: Flex type
Cord specification	: Stainless-steel cord
V-guide	: none
Semi-standard additional specifications	: Tooth-side nylon faced
Additional specifications	: none
Profiled	: included

### 100-L-0100A-JVY

Belt width	: 1 inch (25.4 mm)
Belt model	: L (pitch: 9.525 mm)
Number of belt teeth	: 100 teeth (perimeter: 952.5 mm)
Rubber material	: A (U496)
Type	: Joint type
Cord specification	: Steel cord
V-guide	: included
Semi-standard additional specifications	: none
Additional specifications	: Perforated
Profiled	: none

### 050-MA8-5000E-L

Belt width	: 50 mm
Belt model	: MA8 (pitch: 8 mm)
Number of belt teeth	: 5000 teeth (length: 40 m)
Rubber material	: E (U497)
Type	: Linear type
Cord specification	: Steel cord
V-guide	: none
Semi-standard additional specifications	: none
Additional specifications	: none
Profiled	: none

### 050-FAT1-0150E-J3Y

Belt width	: 50 mm
Belt model	: FAT1 (pitch: 10 mm)
Number of belt teeth	: 150 teeth (perimeter: 1500 mm)
Rubber material	: E (U497)
Type	: Joint type
Cord specification	: Steel cord
V-guide	: none
Semi-standard additional specifications	: Both-side nylon faced
Additional specifications	: Please inform us of the mounting pitch in the case that any perforations are needed to mount any supplied attachments perforated or with dedicated nut. (Please also inform us if perforations are not necessary.) Please inform us of the necessary quantity of dedicated nuts. (If no instructions are received the quantity will be the same number as the number of perforations.)
Profiled	: none

# Dimensions and specifications



This table shows the combination of dimensions and specifications that are supported when manufacturing Iron Rubber belts.

Please contact us in regard to any additional specifications not described in the table.



## How to read the table

### Example of T10 belt

**Type**  
This is used to describe the type of belt.  
**Flex type** : F  
**Joint type** : J  
**Linear type** : L

Type	Belt width (Nominal width)	Length in mm (Number of teeth)	Additional specifications: symbol	Steel cord	High-flex steel cord	Stainless-steel cord	High-flex stainless cord
				Rubber material U497 (E)	Rubber material U497 (E)	Rubber material U497 (E)	Rubber material U497 (E)
	015 020 025 040 050	Minimum: 600 (60) Maximum: 30000 (3000)	Without any additional specifications	E-F	E-FC	E-FS	E-FSC
			Tooth-side nylon faced: 1 Minimum: 1350 (135)	E-F1	E-FC1	E-FS1	E-FSC1
	075 100	Minimum: 1350 (135) Maximum: 30000 (3000)	Without any additional specifications	E-F	E-FC	E-FS	E-FSC
			Tooth-side nylon faced: 1	E-F1	E-FC1	E-FS1	E-FSC1

**Belt width (Nominal width)**  
The width of the belt is described using the nominal width.  
MA belt, AT belt, In meters  
025=25 mm, 100=100 mm  
In inches  
100=1 inch (25.4 mm)

Type	Belt width (Nominal width)	Length in mm (Number of teeth)	Additional specifications: symbol	Steel cord		Aramid cord		
				Rubber material U496 (A)	U497 (E)	Rubber material U496 (A)	U497 (E)	UH01 (G)
	(010) 015 020 025 040 050 075 100	Minimum: 700 (70) Maximum: 50000 (5000)	Without any additional specifications	A-J A-L	E-J E-L	A-JK A-LK	E-JK E-LK	G-JK G-LK
			Tooth-side nylon faced: 1	A-J1 A-L1	—	A-JK1 A-LK1	—	—
			Back-side nylon faced: 2	A-J2 A-L2	—	A-JK2 A-LK2	—	—
			Both-side nylon faced: 3	A-J3 A-L3	—	—	—	—
			Back-side low-hardness: 4	A-J4 A-L4	—	—	—	—
			High-friction nylon faced: 5	A-J5 A-L5	—	—	—	—
			Back-side surface grain: 6	A-J6 A-L6	—	—	—	—

With this example  
Belts lined with fabric on the teeth-side can only be manufactured with a width of at least 1350mm (135 teeth).

Maximum length of belts lined with fabric on the teeth-side, those lined with fabric on the rear, and those lined with nylon on both sides: 50,000 (10,000); and the maximum length of belts with a rear surface grain: 40,000 (4,000).  
With backside low-hardness belts the thickness is 1mm and the total height 5.5mm (minimum number of pulley teeth: 28).  
For high-friction nylon faced belts, the thickness is 0.5mm and the total height is 5.0mm (minimum number of pulley teeth: 20 teeth).  
A width of 10mm is only supported by the Linear type. Linear type belts have no minimum length.

**Length (number of teeth)**  
Provides the supported perimeter and number of the teeth of the belt.  
With this example  
Please use a length (number of the teeth) that is equal to or greater than the following values:  
Perimeter: 700 mm  
Number of teeth: 70

**Additional specifications: Symbols**  
Provides additional belt specifications (fabric coating, etc.) with respect to one-piece molds.  
A separate table should be used for specifications that require additional processing (double width, special backside, and machining).

**Combining specifications**  
Describes whether or not any additional specifications and materials can be combined.  
Provides symbols for supported combinations of model dimensions.  
Please contact us for any combinations marked with a "—" as they require special consideration.

## Materials

### Rubber material

Complies with the 1959 notification No. 370 of the Ministry of Health, Labor, and Welfare (1986 revised notification No. 85 of the Ministry of Health, Labor, and Welfare) and regarding the Food Sanitation Act: Standards for Rubber Equipment (excluding baby bottles etc.) and Containers and Packaging.

Material symbol	Abbreviations	Color	Hardness	Remarks
U496	A	Semi-transparent	A91	
U497	E	White	A91	
U478	D	Semi-transparent	A88	Low-hardness level
UH01	G	White	A91	Includes mold-proof and antimicrobial features

\*The numerical values in the table are actual measured values and are not necessarily standard values.

### Tension member

Type	Material	Remarks
High-tensile steel cord	Steel (galvanized)	—
High-flex steel cord	Steel (galvanized)	C
Stainless-steel cord	SUS304	S
High-flex stainless cord	SUS304	SC
Fiber cord	Aramid fiber	K

### Fabric

Type	Material
Toothed surface fabric/backside fabric	Nylon 6-6
High-friction fabric	Nylon 6-6 + special urethane

Method used to select the dimensions

# Dimensions and specification of MA belt

# MA3

This table provides the supported combinations of dimensions and specification with respect to Iron Rubber belts. Please contact us regarding any specifications not described in the table.

## Example of model dimension indication

### 015-MA3-1350E-FS1

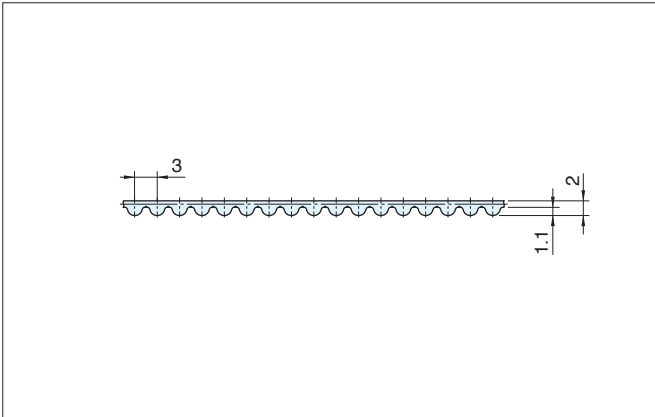
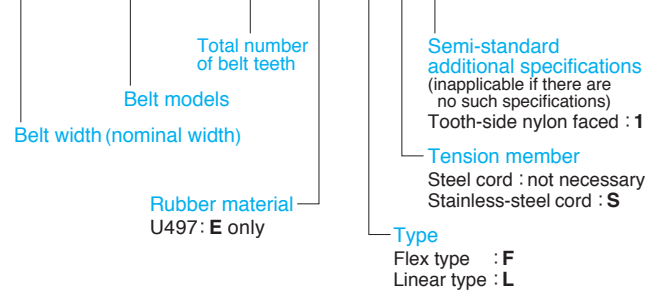

Type	Belt width (Nominal width)	Length in mm (Number of teeth)
<b>F</b> 	007	Minimum: 600 (200)  Maximum: 10002 (3334)
	010	
	015	
	020	
	025	
	040	
	050	

Additional specifications: symbol	Steel cord	Stainless-steel cord
	Rubber material	Rubber material
U497 (E)		
Without any additional specifications	<b>E-F</b>	<b>E-FS</b>
Tooth-side nylon faced : 1 Minimum : 1350 (450)	<b>E-F1</b>	<b>E-FS1</b>

Type	Belt width (Nominal width)	Length in mm (Number of teeth)
<b>L</b> 	007	Maximum: 60000 (20000)
	010	
	015	
	020	
	025	
	040	
	050	

Additional specifications: symbol	Steel cord
	Rubber material
U497 (E)	
Without any additional specifications	<b>E-L</b>
Tooth-side nylon faced : 1	<b>E-L1</b>

The maximum length of any belt lined with fabric on the teeth-side is 50001 (16667).

## Allowable tension F

Unit: N

Belt width mm	Flex type <b>F</b>	Linear type <b>L</b>
7	180	160
10	270	250
15	400	360
20	560	490
25	690	620
40	1140	980
50	1430	1250

The allowable tension only pertains to the tensile load and should not be used as part of the selection criteria.

Please calculate the initial tension setting using the procedure provided on page 76.

Provides numerical values for steel cords.

Set the allowable tension for stainless-steel cords at 80% of the value provided in the table.

## Product mass (reference value)

Unit: g

Model	Flex type <b>F</b>	Joint type <b>J</b>	Linear type <b>L</b>	Remarks
<b>MA3</b>	52	—	52	Width: 25mm, length: 1m



# Dimensions and specification of MA belt

# MA5

This table provides the supported combinations of dimensions and specification with respect to Iron Rubber belts. Please contact us regarding any specifications not described in the table.

## Example of model dimension indication

### 007-MA5-1350E-FS1

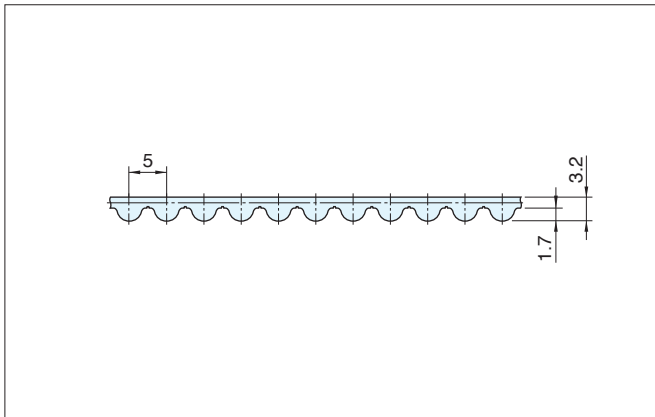
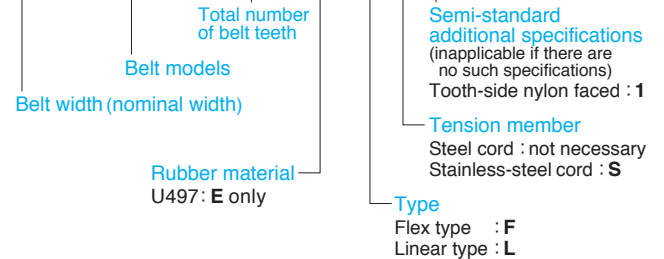

Type	Belt width (Nominal width)	Length in mm (Number of teeth)	Additional specifications: symbol	Steel cord	Stainless-steel cord
				Rubber material	Rubber material
<b>F</b> 	007 010 015 020 025 040 050	Minimum: 600 (120) Maximum: 10000 (2000)	Without any additional specifications	U497 (E)	U497 (E)
				<b>E-F</b>	<b>E-FS</b>
			Tooth-side nylon faced : <b>1</b>	<b>E-F1</b>	<b>E-FS1</b>
			Minimum : 1350 (270)		

Type	Belt width (Nominal width)	Length in mm (Number of teeth)	Additional specifications: symbol	Steel cord	Stainless-steel cord
				Rubber material	Rubber material
<b>L</b> 	007 010 015 020 025 040 050	Maximum: 60000 (12000)	Without any additional specifications	U497 (E)	
				<b>E-L</b>	
			Tooth-side nylon faced : <b>1</b>	<b>E-L1</b>	

The maximum length of any belt lined with fabric on the teeth-side is 50000 (10000).

## Allowable tension **F**

Unit : N

Belt width mm	Flex type <b>F</b>	Linear type <b>L</b>
7	260	310
10	420	470
15	690	740
20	950	960
25	1220	1270
40	2010	2010
50	2540	2540

## Product mass (reference value)

Unit : g

Model	Flex type <b>F</b>	Joint type <b>J</b>	Linear type <b>L</b>	Remarks
<b>MA5</b>	96	—	96	Width: 25mm, length: 1m

The allowable tension only pertains to the tensile load and should not be used as part of the selection criteria.

Please calculate the initial tension setting using the procedure provided on page 76.

Provides numerical values for steel cords.

Set the allowable tension for stainless-steel cords at 80% of the value provided in the table.

# Dimensions and specification of MA belt

# MA8

This table provides the supported combinations of dimensions and specification with respect to Iron Rubber belts. Please contact us regarding any specifications not described in the table.

## Example of model dimension indication

### 075-MA8-1360E-FS1

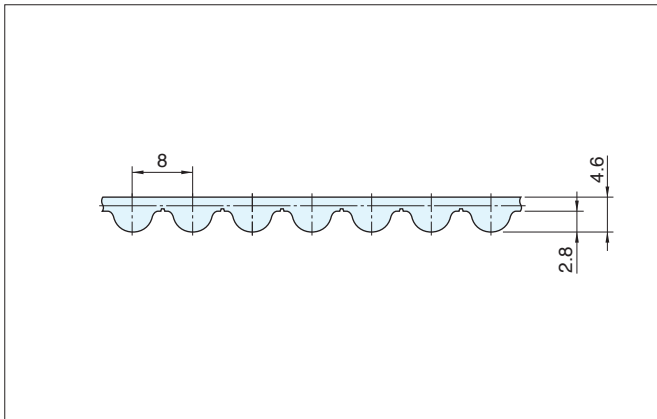
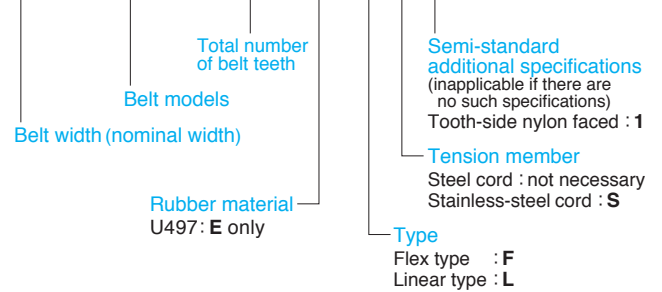

Type	Belt width (Nominal width)	Length in mm (Number of teeth)
<b>F</b> 	015 020 025 040 050	Minimum: 600 (75) Maximum: 30000 (3750)
	075 100	Minimum: 1352 (169) Maximum: 30000 (3750)

Additional specifications: symbol	Steel cord	Stainless-steel cord
	Rubber material U497 (E)	Rubber material U497 (E)
Without any additional specifications	<b>E-F</b>	<b>E-FS</b>
Tooth-side nylon faced : 1 Minimum: 1352 (169)	<b>E-F1</b>	<b>E-FS1</b>
Without any additional specifications	<b>E-F</b>	<b>E-FS</b>
Tooth-side nylon faced : 1	<b>E-F1</b>	<b>E-FS1</b>

Type	Belt width (Nominal width)	Length in mm (Number of teeth)
<b>L</b> 	015 020 025 040 050 075 100	Maximum: 40000 (5000)

Additional specifications: symbol	Steel cord
	Rubber material U497 (E)
Without any additional specifications	<b>E-L</b>
Tooth-side nylon faced : 1	<b>E-L1</b>

## Allowable tension **F**

Unit : N

Belt width mm	Flex type <b>F</b>	Linear type <b>L</b>
15	1440	1620
20	2160	2160
25	2700	2700
40	4500	4320
50	5760	5400
75	8640	8100
100	11700	10800

The allowable tension only pertains to the tensile load and should not be used as part of the selection criteria.

Please calculate the initial tension setting using the procedure provided on page 76.

Provides numerical values for steel cords.

Set the allowable tension for stainless-steel cords at 80% of the value provided in the table.

## Product mass (reference value)

Unit : g

Model	Flex type <b>F</b>	Joint type <b>J</b>	Linear type <b>L</b>	Remarks
<b>MA8</b>	148	—	148	Width: 25mm, length: 1m

# Dimensions and specification of AT belt

# AT5

This table provides the supported combinations of dimensions and specification with respect to Iron Rubber belts. Please contact us regarding any specifications not described in the table.

## Example of model dimension indication

### 015-AT5-1350E-FC1

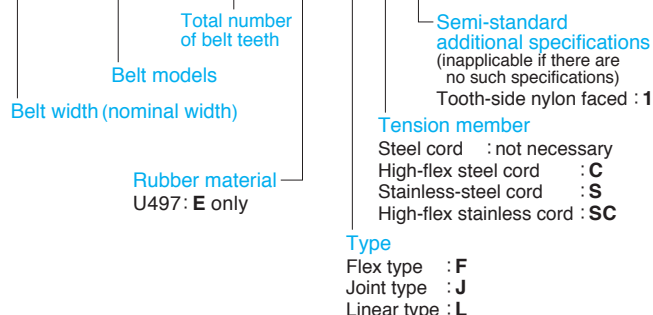
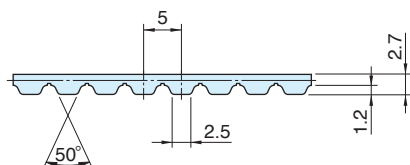

Type	Belt width (Nominal width)	Length in mm (Number of teeth)
<b>F</b>	007	Minimum: 600 (120) Maximum: 10000 (2000)
	010	
	015	
	020	
	025	
	040	
	050	

Additional specifications: symbol	Steel cord	High-flex steel cord	Stainless-steel cord	High-flex stainless cord
	Rubber material U497 (E)	Rubber material U497 (E)	Rubber material U497 (E)	Rubber material U497 (E)
Without any additional specifications	<b>E-F</b>	<b>E-FC</b>	<b>E-FS</b>	<b>E-FSC</b>
Tooth-side nylon faced : 1 Minimum : 1350 (270)	<b>E-F1</b>	<b>E-FC1</b>	<b>E-FS1</b>	<b>E-FSC1</b>

Type	Belt width (Nominal width)	Length in mm (Number of teeth)
<b>J</b>	007	Minimum: 460 (92) Maximum: 60000 (12000)
	010	
	015	
	020	
	025	
<b>L</b>	040	
	050	

Additional specifications: symbol	Steel cord
	Rubber material U497 (E)
Without any additional specifications	<b>E-J</b> <b>E-L</b>
Tooth-side nylon faced : 1	<b>E-J1</b> <b>E-L1</b>

The maximum length of any belt lined with fabric on the teeth-side is 50000 (10000). Linear type belts have no minimum length.

## Allowable tension F

Unit: N

Belt width mm	Flex type <b>F</b>	Joint type <b>F</b>	Linear type <b>L</b>
7	260	130	310
10	420	210	470
15	690	320	740
20	950	410	960
25	1220	620	1270
40	2010	920	2010
50	2540	1240	2540

The allowable tension only pertains to the tensile load and should not be used as part of the selection criteria.

Please calculate the initial tension setting using the procedure provided on page 76.

Provides numerical values for steel cords.

Set the allowable tension for stainless-steel cords at 80% of the value provided in the table.

## Product mass (reference value)

Unit: g

Model	Flex type <b>F</b>	Joint type <b>J</b>	Linear type <b>L</b>	Remarks
<b>AT5</b>	82	82		Width: 25mm, length: 1m

# Dimensions and specification of AT belt

# AT10

This table provides the supported combinations of dimensions and specification with respect to Iron Rubber belts. Please contact us regarding any specifications not described in the table.

## Example of model dimension indication

### 015-AT10-1350E-FC1

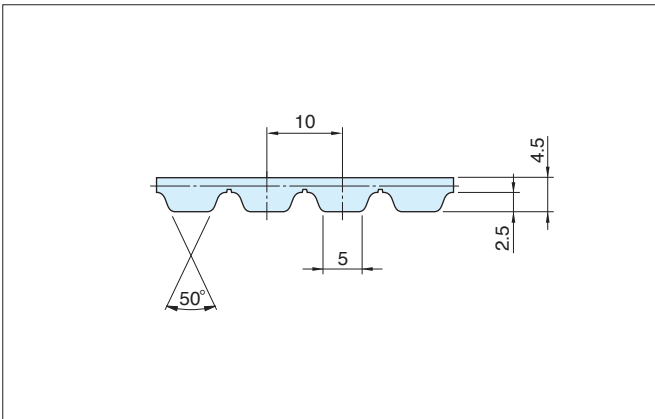
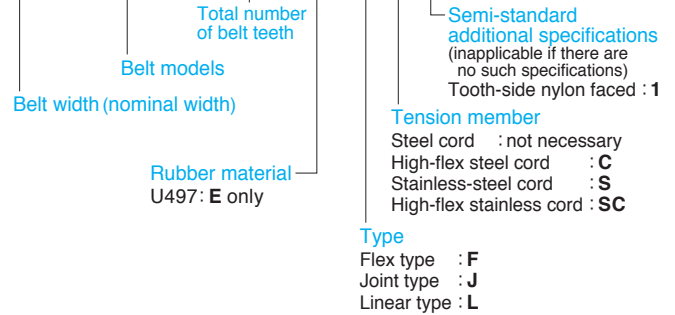

Type	Belt width (Nominal width)	Length in mm (Number of teeth)	Additional specifications: symbol	Steel cord	High-flex steel cord	Stainless-steel cord	High-flex stainless cord
				Rubber material	Rubber material	Rubber material	Rubber material
				U497 (E)	U497 (E)	U497 (E)	U497 (E)
<b>F</b> 	015 020 025 040 050	Minimum: 600 (60)	Without any additional specifications	<b>E-F</b>	<b>E-FC</b>	<b>E-FS</b>	<b>E-FSC</b>
		Maximum: 30000 (3000)	Tooth-side nylon faced : 1 Minimum: 1350 (135)	<b>E-F1</b>	<b>E-FC1</b>	<b>E-FS1</b>	<b>E-FSC1</b>
	075 100	Minimum: 1350 (135)	Without any additional specifications	<b>E-F</b>	<b>E-FC</b>	<b>E-FS</b>	<b>E-FSC</b>
		Maximum: 30000 (3000)	Tooth-side nylon faced : 1	<b>E-F1</b>	<b>E-FC1</b>	<b>E-FS1</b>	<b>E-FSC1</b>

Type	Belt width (Nominal width)	Length in mm (Number of teeth)	Additional specifications: symbol	Steel cord	
				Rubber material	
				U497 (E)	
<b>J</b>  <b>L</b> 	015 020 025 040 050 075 100	Minimum: 700 (70)	Without any additional specifications	<b>E-J</b> <b>E-L</b>	
		Maximum: 40000 (4000)	Tooth-side nylon faced : 1	<b>E-J1</b> <b>E-L1</b>	

Linear type belts have no minimum length.

## Allowable tension **F**

Unit: N

Belt width mm	Flex type <b>F</b>	Joint type <b>F</b>	Linear type <b>L</b>
15	1440	710	1620
20	2160	890	2160
25	2700	1070	2700
40	4500	1960	4320
50	5760	2500	5400
75	8640	3650	8100
100	11700	5000	10800

The allowable tension only pertains to the tensile load and should not be used as part of the selection criteria.

Please calculate the initial tension setting using the procedure provided on page 76.

Provides numerical values for steel cords.

Set the allowable tension for stainless-steel cords at 80% of the value provided in the table.

## Product mass (reference value)

Unit: g

Model	Flex type <b>F</b>	Joint type <b>J</b>	Linear type <b>L</b>	Remarks
<b>AT10</b>	150	150		Width: 25mm, length: 1m

# Dimensions and specification of AT belt

## AT20

This table provides the supported combinations of dimensions and specification with respect to Iron Rubber belts. Please contact us regarding any specifications not described in the table.

### Example of model dimension indication

#### 025-AT20-0136E-FS 1

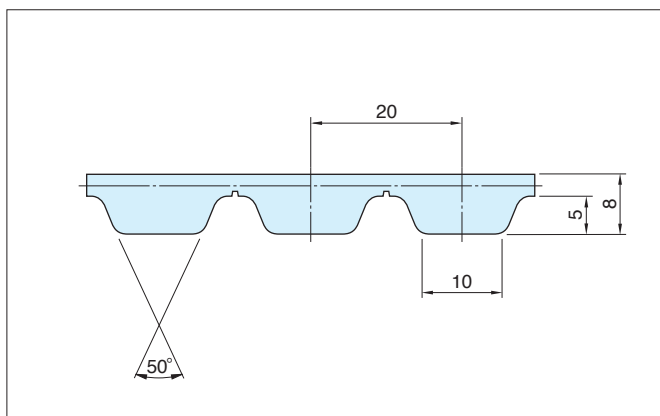
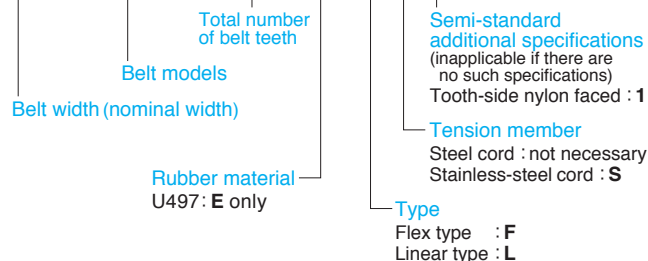

Type	Belt width (Nominal width)	Length in mm (Number of teeth)
<b>F</b> 	025	Minimum: 1360 (68)
	040	
	050	Maximum: 30000 (1500)
	075	
	100	

Additional specifications: symbol	Steel cord	Stainless-steel cord
	Rubber material	Rubber material
	U497 (E)	U497 (E)
Without any additional specifications	<b>E-F</b>	<b>E-FS</b>
Tooth-side nylon faced : 1	<b>E-F1</b>	<b>E-FS1</b>

Type	Belt width (Nominal width)	Length in mm (Number of teeth)
<b>L</b> 	025	Maximum: 25000 (1250)
	040	
	050	
	075	
	100	

Additional specifications: symbol	Steel cord
	Rubber material
	U497 (E)
Without any additional specifications	<b>E-L</b>
Tooth-side nylon faced : 1	<b>E-L1</b>

### Allowable tension **F**

Unit: N

Belt width mm	Flex type <b>F</b>	Linear type <b>L</b>
25	4360	4700
40	7390	7720
50	9220	9740
75	14440	14440
100	19150	19480

The allowable tension only pertains to the tensile load and should not be used as part of the selection criteria. Please calculate the initial tension setting using the procedure provided on page 76. Provides numerical values for steel cords. Set the allowable tension for stainless-steel cords at 80% of the value provided in the table.

### Product mass (reference value)

Unit: g

Model	Flex type <b>F</b>	Joint type <b>J</b>	Linear type <b>L</b>	Remarks
<b>AT20</b>	265	—	265	Width: 25mm, length: 1m

# Dimensions and specifications of trapezium teathed belts (meters)

## T5

This table provides the supported combinations of dimensions and specification with respect to Iron Rubber belts. Please contact us regarding any specifications not described in the table.

### Example of model dimension indication

#### 025-T5-0350E-FS1

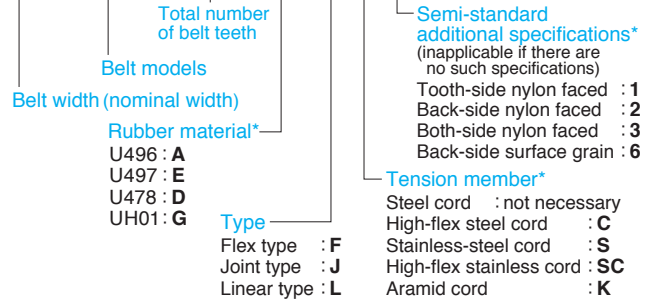

\*Please refer to the table below for the supported combinations of rubber material, tension member, and additional specifications.

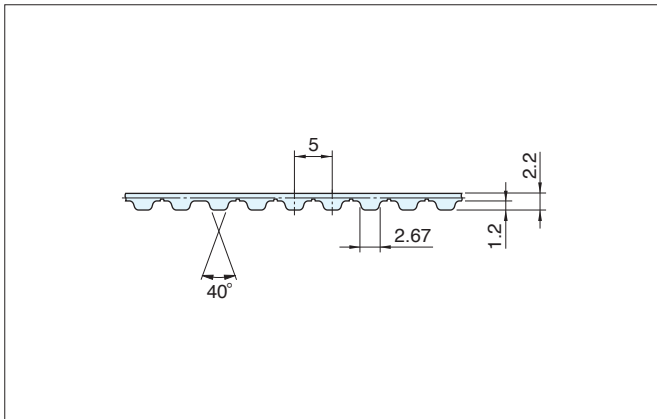

Type	Belt width (Nominal width)	Length in mm (Number of teeth)
<b>F</b> 	007	Minimum: 600 (120)
	010	
	015	Maximum: 10000 (2000)
	020	
	025	
	040	
	050	

Additional specifications: symbol	Steel cord	High-flex steel cord	Stainless-steel cord	High-flex stainless cord
	Rubber material	Rubber material	Rubber material	Rubber material
Without any additional specifications	U497 (E)	U497 (E)	U497 (E)	U497 (E)
Without any additional specifications	<b>E-F</b>	<b>E-FC</b>	<b>E-FS</b>	<b>E-FSC</b>
Tooth-side nylon faced : 1 Minimum: 1350 (270)	<b>E-F1</b>	<b>E-FC1</b>	<b>E-FS1</b>	<b>E-FSC1</b>

Type	Belt width (Nominal width)	Length in mm (Number of teeth)
<b>J</b> 	007	Minimum: 250 (50)
	010	
	015	Maximum: 60000 (12000)
	020	
	025	
<b>L</b> 	040	Minimum: 455 (91)
	050	

Additional specifications: symbol	Steel cord			Aramid cord		
	Rubber material			Rubber material		
	U496 (A)	U497 (E)	U478 (D)	U496 (A)	U497 (E)	UH01 (G)
Without any additional specifications	<b>A-J</b> <b>A-L</b>	<b>E-J</b> <b>E-L</b>	<b>D-J</b> <b>D-L</b>	<b>A-JK</b> <b>A-LK</b>	<b>E-JK</b> <b>E-LK</b>	<b>G-JK</b> <b>G-LK</b>
Tooth-side nylon faced : 1	<b>A-J1</b> <b>A-L1</b>	—	—	—	—	—
Back-side nylon faced : 2	<b>A-J2</b> <b>A-L2</b>	—	—	—	—	—
Both-side nylon faced : 3	<b>A-J3</b> <b>A-L3</b>	—	—	—	—	—
Back-side surface grain : 6	<b>A-J6</b> <b>A-L6</b>	—	—	—	—	—

Maximum length of belts lined with fabric on the teeth-side, those lined with fabric on the rear, and those lined with nylon on both sides: 50,000 (10,000); and the maximum length of belts with a rear surface grain: 40,000 (8,000)  
 Linear type belts have no minimum length.

### Allowable tension **F** Unit: N

Belt width mm	Flex type <b>F</b>	Joint type <b>J</b>	Linear type <b>L</b>
7	180	75	160
10	270	110	250
15	400	160	360
20	560	210	490
25	690	310	620
40	1140	490	980
50	1430	630	1250

The allowable tension only pertains to the tensile load and should not be used as part of the selection criteria. Please calculate the initial tension setting using the procedure provided on page 76. Provides numerical values for steel cords and aramid cords. Set the allowable tension for stainless-steel cords at 80% of the value provided in the table.

### Product mass (reference value) Unit: g

Model	Flex type <b>F</b>	Joint type <b>J</b>	Linear type <b>L</b>	Remarks
<b>T5</b>	53	52 (48)		Width: 25mm, length: 1m

( ) : aramid fiber cord products

# Dimensions and specifications of trapezium teathed belts (meters)

# T10

This table provides the supported combinations of dimensions and specification with respect to Iron Rubber belts. Please contact us regarding any specifications not described in the table.

## Example of model dimension indication

### 025-T10-1500A-JK1

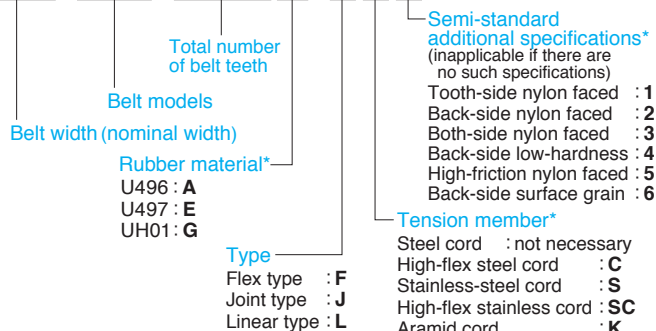
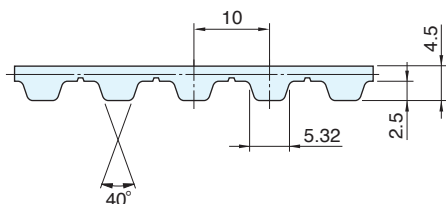

\*Please refer to the table below for the supported combinations of rubber material, tension member, and additional specifications.

Type	Belt width (Nominal width)	Length in mm (Number of teeth)	Additional specifications: symbol	Steel cord	High-flex steel cord	Stainless-steel cord	High-flex stainless cord
				Rubber material	Rubber material	Rubber material	Rubber material
<b>F</b> 	015 020 025 040 050	Minimum: 600 (60) Maximum: 30000 (3000)	Without any additional specifications	<b>E-F</b>	<b>E-FC</b>	<b>E-FS</b>	<b>E-FSC</b>
			Tooth-side nylon faced : 1 Minimum: 1350 (135)	<b>E-F1</b>	<b>E-FC1</b>	<b>E-FS1</b>	<b>E-FSC1</b>
	075 100	Minimum: 1350 (135) Maximum: 30000 (3000)	Without any additional specifications	<b>E-F</b>	<b>E-FC</b>	<b>E-FS</b>	<b>E-FSC</b>
			Tooth-side nylon faced : 1	<b>E-F1</b>	<b>E-FC1</b>	<b>E-FS1</b>	<b>E-FSC1</b>

Type	Belt width (Nominal width)	Length in mm (Number of teeth)	Additional specifications: symbol	Steel cord		Aramid cord		
				Rubber material		Rubber material		
				U496 (A)	U497 (E)	U496 (A)	U497 (E)	UH01 (G)
<b>J</b>  <b>L</b> 	(010) 015 020 025 040 050 075 100	Minimum: 700 (70) Maximum: 50000 (5000)	Without any additional specifications	<b>A-J</b> <b>A-L</b>	<b>E-J</b> <b>E-L</b>	<b>A-JK</b> <b>A-LK</b>	<b>E-JK</b> <b>E-LK</b>	<b>G-JK</b> <b>G-LK</b>
			Tooth-side nylon faced : 1	<b>A-J1</b> <b>A-L1</b>	—	<b>A-JK1</b> <b>A-LK1</b>	—	—
			Back-side nylon faced : 2	<b>A-J2</b> <b>A-L2</b>	—	<b>A-JK2</b> <b>A-LK2</b>	—	—
			Both-side nylon faced : 3	<b>A-J3</b> <b>A-L3</b>	—	—	—	—
			Back-side low-hardness : 4	<b>A-J4</b> <b>A-L4</b>	—	—	—	—
			High-friction nylon faced : 5	<b>A-J5</b> <b>A-L5</b>	—	—	—	—
			Back-side surface grain : 6	<b>A-J6</b> <b>A-L6</b>	—	—	—	—

Maximum length of belts lined with fabric on the teeth-side, those lined with fabric on the rear, and those lined with nylon on both sides: 50,000 (5,000); and the maximum length of belts with a rear surface grain: 40,000 (4,000). With backside low-hardness belts the thickness is 1mm and the total height 5.5mm (minimum number of pulley teeth: 28). For high-friction nylon faced belts, the thickness is 0.5mm and the total height is 5.0mm (minimum number of pulley teeth: 20 teeth). A width of 10mm is only supported by the Linear type. Linear type belts have no minimum length.

## Allowable tension **F** Unit : N

Belt width mm	Flex type <b>F</b>	Joint type <b>J</b>	Linear type <b>L</b>
10	—	—	470
15	790	290	640
20	1100	400	880
25	1420	640	1280
40	2400	960	1920
50	3040	1280	2560
75	4560	1920	3840
100	6160	2560	5120

## Product mass (reference value) Unit : g

Model	Flex type <b>F</b>	Joint type <b>J</b>	Linear type <b>L</b>	Remarks
<b>T10</b>	110	110 (92)		Width: 25mm, length: 1m

( ) : aramid fiber cord products

The allowable tension only pertains to the tensile load and should not be used as part of the selection criteria. Please calculate the initial tension setting using the procedure provided on page 76. Provides numerical values for steel cords and aramid cords. Set the allowable tension for stainless-steel cords at 80% of the value provided in the table.

# Dimensions and specifications of trapezium teathed belts (meters)

## T20

This table provides the supported combinations of dimensions and specification with respect to Iron Rubber belts. Please contact us regarding any specifications not described in the table.

### Example of model dimension indication

#### 075-T20-1200E-FS1

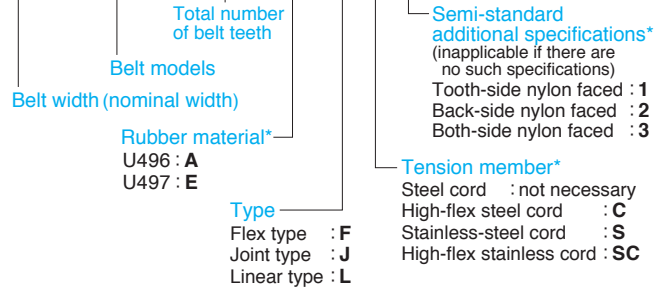

\*Please refer to the table below for the supported combinations of rubber material, tension member, and additional specifications.

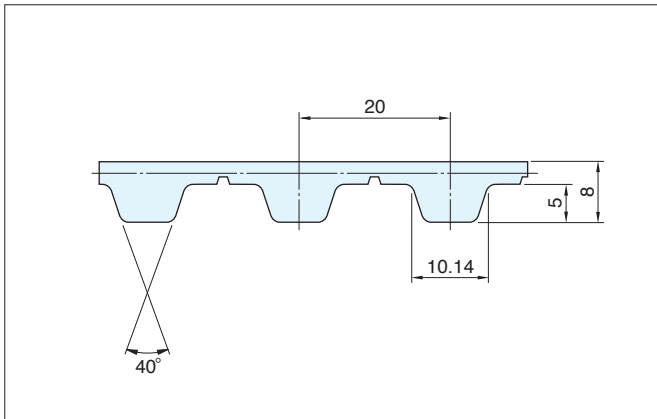

Type	Belt width (Nominal width)	Length in mm (Number of teeth)
<b>F</b> 	025	Minimum: 1360 (68)
	040	
	050	Maximum: 30000 (1500)
	075	
	100	

Additional specifications: symbol	Steel cord	High-flex steel cord	Stainless-steel cord	High-flex stainless cord
	Rubber material	Rubber material	Rubber material	Rubber material
	U497 (E)	U497 (E)	U497 (E)	U497 (E)
Without any additional specifications	<b>E-F</b>	<b>E-FC</b>	<b>E-FS</b>	<b>E-FSC</b>
Tooth-side nylon faced : 1	<b>E-F1</b>	<b>E-FC1</b>	<b>E-FS1</b>	<b>E-FSC1</b>

Type	Belt width (Nominal width)	Length in mm (Number of teeth)
<b>J</b> 	(020)	Minimum: 1000 (50)
	025	
	040	Maximum: 30000 (1500)
	050	
	075	
<b>L</b> 	100	

Additional specifications: symbol	Steel cord	
	Rubber material	
	U496 (A)	U497 (E)
Without any additional specifications	<b>A-J</b> <b>A-L</b>	<b>E-J</b> <b>E-L</b>
Tooth-side nylon faced : 1	<b>A-J1</b> <b>A-L1</b>	<b>E-J1</b> <b>E-L1</b>
Back-side nylon faced : 2	<b>A-J2</b> <b>A-L2</b>	—
Both-side nylon faced : 3	<b>A-J3</b> <b>A-L3</b>	—

A width of 20mm is only supported by the Linear type. Linear type belts have no minimum length.

### Allowable tension F

Unit : N

Belt width mm	Flex type <b>F</b>	Joint type <b>J</b>	Linear type <b>L</b>
20	—	—	1800
25	2700	800	2340
40	4320	1620	3960
50	5400	2500	5040
75	8280	3780	7560
100	11000	5040	10080

The allowable tension only pertains to the tensile load and should not be used as part of the selection criteria.

Please calculate the initial tension setting using the procedure provided on page 76.

Provides numerical values for steel cords.

Set the allowable tension for stainless-steel cords at 80% of the value provided in the table.

### Product mass (reference value)

Unit : g

Model	Flex type <b>F</b>	Joint type <b>J</b>	Linear type <b>L</b>	Remarks
<b>T20</b>	188	180		Width: 25mm, length: 1m



# Dimensions and specifications of trapezium teathed belts (inches)

# MXL

This table provides the supported combinations of dimensions and specification with respect to Iron Rubber belts. Please contact us regarding any specifications not described in the table.

## Example of model dimension indication

### 013-MXL-1000D-LK

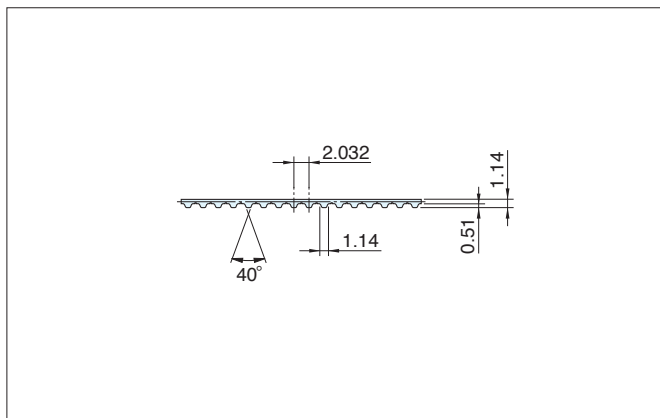
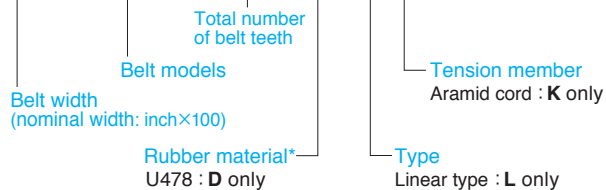

Type	Belt width (Nominal width)		Length in mm (Number of teeth)	Additional specifications: symbol	Aramid cord	
		mm			Rubber material	
	013	3.2	Maximum: 50000 (24607)	Without any additional specifications	U478 (D)	
	019	4.8			D-LK	
	025	6.4				
	031	7.9				
	037	9.5				
	050	12.7				
	075	19.1				
	100	25.4				

Dimensions and specifications

## Allowable tension **F**

Unit : N

Belt width		Linear type <b>L</b>
Nominal width	mm	
013	3.2	45
019	4.8	65
025	6.4	90
031	7.9	120
037	9.5	140
050	12.7	175
075	19.1	260
100	25.4	350

The allowable tension only pertains to the tensile load and should not be used as part of the selection criteria. Please calculate the initial tension setting using the procedure provided on page 76.

## Product mass (reference value)

Unit : g

Model	Flex type <b>F</b>	Joint type <b>J</b>	Linear type <b>L</b>	Remarks
<b>MXL</b>	—	—	25	Width: 25mm, length: 1m

# Dimensions and specifications of trapezium teathed belts (inches)

# XL

This table provides the supported combinations of dimensions and specification with respect to Iron Rubber belts. Please contact us regarding any specifications not described in the table.

## Example of model dimension indication

### 025-XL-1250E-FS1

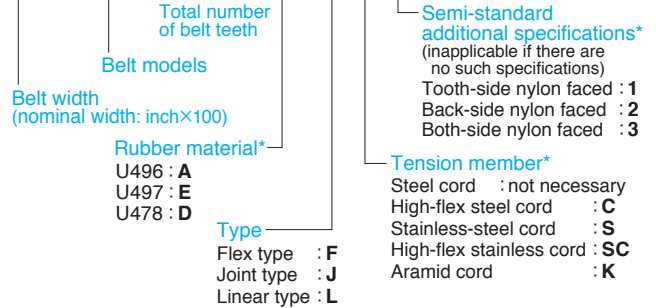
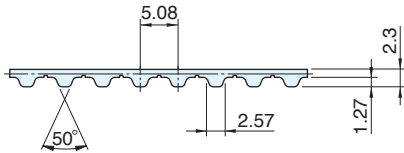

\*Please refer to the table below for the supported combinations of rubber material, tension member, and additional specifications.

Type	Belt width (Nominal width)		Length in mm (Number of teeth)
	mm		
<b>F</b> 	025	6.4	Minimum: 609.6 (120) Maximum: 10007.6 (1970)
	031	7.9	
	037	9.5	
	050	12.7	
	075	19.1	
	100	25.4	
	200	50.8	

Additional specifications: symbol	Steel cord	High-flex steel cord	Stainless-steel cord	High-flex stainless cord
	Rubber material	Rubber material	Rubber material	Rubber material
	U497 (E)	U497 (E)	U497 (E)	U497 (E)
Without any additional specifications	<b>E-F</b>	<b>E-FC</b>	<b>E-FS</b>	<b>E-FSC</b>
Tooth-side nylon faced : 1 Minimum: 1351.28 (266)	<b>E-F1</b>	<b>E-FC1</b>	<b>E-FS1</b>	<b>E-FSC1</b>

Type	Belt width (Nominal width)		Length in mm (Number of teeth)
	mm		
<b>J</b> 	025	6.4	Minimum: 254 (50) Maximum: 60000 (11812)
	031	7.9	
	037	9.5	
	050	12.7	
	075	19.1	
<b>L</b> 	100	25.4	Minimum: 457.2 (90) Maximum: 60000 (11812)
	150	38.1	
	200	50.8	

Additional specifications: symbol	Steel cord			Aramid cord	
	Rubber material			Rubber material	
	U496 (A)	U497 (E)	U478 (D)	U496 (A)	U497 (E)
Without any additional specifications	<b>A-J</b> <b>A-L</b>	<b>E-J</b> <b>E-L</b>	<b>D-J</b> <b>D-L</b>	<b>A-JK</b> <b>A-LK</b>	<b>E-JK</b> <b>E-LK</b>
Tooth-side nylon faced : 1	<b>A-J1</b> <b>A-L1</b>	—	—	—	—
Back-side nylon faced : 2	<b>A-J2</b> <b>A-L2</b>	—	—	—	—
Both-side nylon faced : 3	<b>A-J3</b> <b>A-L3</b>	—	—	—	—

Maximum length of belts lined with fabric on the teeth-side, those lined with fabric on the rear, and those lined with nylon on both sides: 50,000 (10,000)  
Linear type belts have no minimum length.

## Allowable tension **F**

Unit: N

Belt width		Flex type <b>F</b>	Joint type <b>J</b>	Linear type <b>L</b>
Nominal width	mm			
025	6.4	155	70	160
031	7.9	200	90	180
037	9.5	245	110	220
050	12.7	330	155	310
075	19.1	530	235	470
100	25.4	690	310	620
150	38.1	1050	470	940
200	50.8	1450	630	1250

The allowable tension only pertains to the tensile load and should not be used as part of the selection criteria.

Please calculate the initial tension setting using the procedure provided on page 76.

Provides numerical values for steel cords and aramid cords.

Set the allowable tension for stainless-steel cords at 80% of the value provided in the table.

## Product mass (reference value)

Unit: g

Model	Flex type <b>F</b>	Joint type <b>J</b>	Linear type <b>L</b>	Remarks
<b>XL</b>	57	56 (52)		Width: 25.4mm, length: 1m

( ) : aramid fiber cord products

# Dimensions and specifications of trapezium teathed belts (inches)



This table provides the supported combinations of dimensions and specification with respect to Iron Rubber belts. Please contact us regarding any specifications not described in the table.

## Example of model dimension indication

### 200-L-0250E-FC1

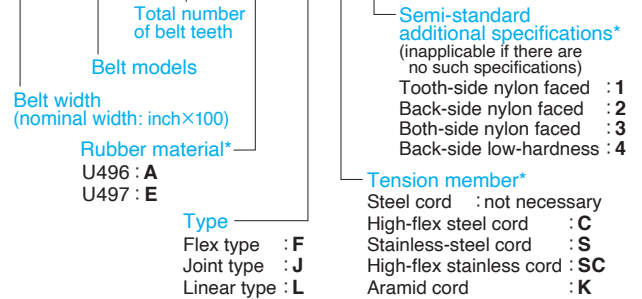

\*Please refer to the table below for the supported combinations of rubber material, tension member, and additional specifications.

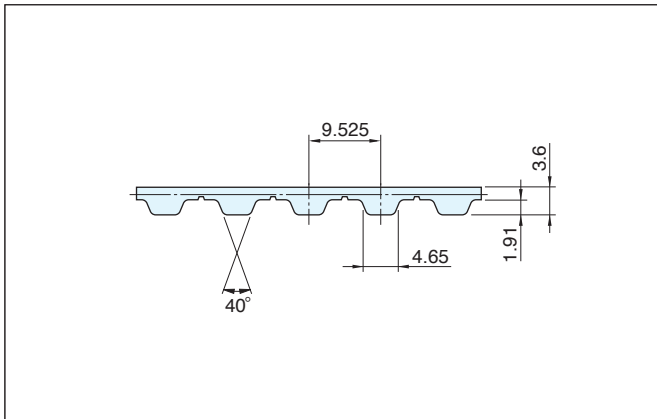

Type	Belt width (Nominal width)		Length in mm (Number of teeth)	Additional specifications: symbol	Steel cord	High-flex steel cord	Stainless-steel cord	High-flex stainless cord
	mm				Rubber material	Rubber material	Rubber material	Rubber material
					U497 (E)	U497 (E)	U497 (E)	U497 (E)
<b>F</b> 	050	12.7	Minimum: 600.08 (63) Maximum: 10001.25 (1050)	Without any additional specifications	<b>E-F</b>	<b>E-FC</b>	<b>E-FS</b>	<b>E-FSC</b>
	075	19.1		Tooth-side nylon faced : 1	<b>E-F1</b>	<b>E-FC1</b>	<b>E-FS1</b>	<b>E-FSC1</b>
	100	25.4		Minimum: 1352.55 (142)	<b>E-F</b>	<b>E-FC</b>	<b>E-FS</b>	<b>E-FSC</b>
	150	38.1	Maximum: 10001.25 (1050)	Without any additional specifications	<b>E-F</b>	<b>E-FC</b>	<b>E-FS</b>	<b>E-FSC</b>
	200	50.8		Tooth-side nylon faced : 1	<b>E-F1</b>	<b>E-FC1</b>	<b>E-FS1</b>	<b>E-FSC1</b>
	300	76.2		Minimum: 1352.55 (142)	<b>E-F</b>	<b>E-FC</b>	<b>E-FS</b>	<b>E-FSC</b>
400	101.6	Maximum: 10001.25 (1050)	Tooth-side nylon faced : 1	<b>E-F1</b>	<b>E-FC1</b>	<b>E-FS1</b>	<b>E-FSC1</b>	

Type	Belt width (Nominal width)		Length in mm (Number of teeth)	Additional specifications: symbol	Steel cord		Aramid cord	
	mm				Rubber material		Rubber material	
					U496 (A)	U497 (E)	U496 (A)	U497 (E)
<b>J</b>  <b>L</b> 	050	12.7	Minimum: 666.75 (70) Maximum: 59998 (6299)	Without any additional specifications	<b>A-J</b> <b>A-L</b>	<b>E-J</b> <b>E-L</b>	<b>A-JK</b> <b>A-LK</b>	<b>E-JK</b> <b>E-LK</b>
	075	19.1		Tooth-side nylon faced : 1	<b>A-J1</b> <b>A-L1</b>	—	—	—
	100	25.4		Back-side nylon faced : 2	<b>A-J2</b> <b>A-L2</b>	—	—	—
	150	38.1	Maximum: 59998 (6299)	Both-side nylon faced : 3	<b>A-J3</b> <b>A-L3</b>	—	—	—
	200	50.8		Back-side low-hardness : 4	<b>A-J4</b> <b>A-L4</b>	—	—	—

Maximum length of belts lined with fabric on the teeth-side, those lined with fabric on the rear, and those lined with nylon on both sides: 50,000 (5,250)

With backside low-hardness belts the thickness is 1mm and the total height 4.6mm (minimum number of pulley teeth: 18). Linear type belts have no minimum length.

## Allowable tension **F**

Unit : N

Belt width		Flex type <b>F</b>	Joint type <b>J</b>	Linear type <b>L</b>
Nominal width	mm			
050	12.7	530	320	640
075	19.1	900	480	960
100	25.4	1280	640	1280
150	38.1	1900	950	1900
200	50.8	2600	1270	2540
300	76.2	3820	—	—
400	101.6	5250	—	—

## Product mass (reference value)

Unit : g

Model	Flex type <b>F</b>	Joint type <b>J</b>	Linear type <b>L</b>	Remarks
<b>L</b>	92	92 (84)		Width: 25.4mm, length: 1m

( ) : aramid fiber cord products

The allowable tension only pertains to the tensile load and should not be used as part of the selection criteria. Please calculate the initial tension setting using the procedure provided on page 76. Provides numerical values for steel cords and aramid cords. Set the allowable tension for stainless-steel cords at 80% of the value provided in the table.

# Dimensions and specifications of trapezium teathed belts (inches)

# H

This table provides the supported combinations of dimensions and specification with respect to Iron Rubber belts. Please contact us regarding any specifications not described in the table.

## Example of model dimension indication

### 075-H-0250E-FC1

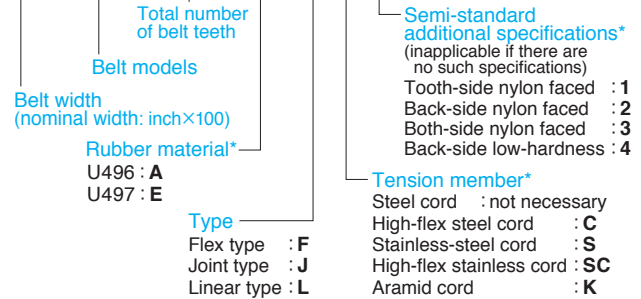

\*Please refer to the table below for the supported combinations of rubber material, tension member, and additional specifications.

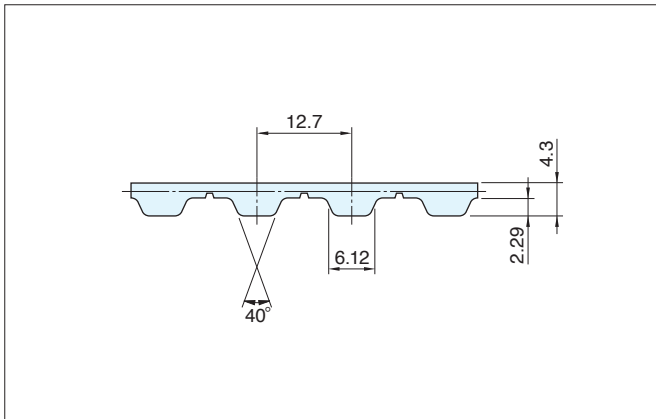

Type	Belt width (Nominal width)		Length in mm (Number of teeth)	Additional specifications: symbol	Steel cord	High-flex steel cord	Stainless-steel cord	High-flex stainless cord	
	mm	mm			Rubber material	Rubber material	Rubber material	Rubber material	
					U497 (E)	U497 (E)	U497 (E)	U497 (E)	
<b>F</b> 	075	19.1	Minimum: 609.6 (48)	Without any additional specifications	<b>E-F</b>	<b>E-FC</b>	<b>E-FS</b>	<b>E-FSC</b>	
	100	25.4		Maximum: 30010 (2363)	Tooth-side nylon faced : 1	<b>E-F1</b>	<b>E-FC1</b>	<b>E-FS1</b>	<b>E-FSC1</b>
	150	38.1	Minimum: 1358.9 (107)		Without any additional specifications	<b>E-F</b>	<b>E-FC</b>	<b>E-FS</b>	<b>E-FSC</b>
	200	50.8			Tooth-side nylon faced : 1	<b>E-F1</b>	<b>E-FC1</b>	<b>E-FS1</b>	<b>E-FSC1</b>
	300	76.2	Maximum: 30010 (2363)		Without any additional specifications	<b>E-F</b>	<b>E-FC</b>	<b>E-FS</b>	<b>E-FSC</b>
	400	101.6		Tooth-side nylon faced : 1	<b>E-F1</b>	<b>E-FC1</b>	<b>E-FS1</b>	<b>E-FSC1</b>	

Type	Belt width (Nominal width)		Length in mm (Number of teeth)	Additional specifications: symbol	Steel cord		Aramid cord	
	mm	mm			Rubber material	Rubber material	Rubber material	Rubber material
					U496 (A)	U497 (E)	U496 (A)	U497 (E)
<b>J</b>  <b>L</b> 	075	19.1	Minimum: 711.2 (56)	Without any additional specifications	<b>A-J</b> <b>A-L</b>	<b>E-J</b> <b>E-L</b>	<b>A-JK</b> <b>A-LK</b>	<b>E-JK</b> <b>E-LK</b>
	100	25.4		Maximum: 50000 (3938)	Tooth-side nylon faced : 1	<b>A-J1</b> <b>A-L1</b>	—	<b>A-JK1</b> <b>A-LK1</b>
	150	38.1	Back-side nylon faced : 2		<b>A-J2</b> <b>A-L2</b>	—	—	—
	200	50.8			Both-side nylon faced : 3	<b>A-J3</b> <b>A-L3</b>	—	—
	300	76.2	Back-side low-hardness : 4			<b>A-J4</b> <b>A-L4</b>	—	—
	400	101.6						

With backside low-hardness belts the thickness is 1mm and the total height 5.3mm (minimum number of pulley teeth: 25). Linear type belts have no minimum length.

## Allowable tension F

Unit : N

Belt width		Flex type F	Joint type J	Linear type L
Nominal width	mm			
075	19.1	1040	380	960
100	25.4	1440	640	1280
150	38.1	2240	960	1920
200	50.8	3040	1280	2560
300	76.2	4640	1920	3840
400	101.6	6320	2560	5120

## Product mass (reference value)

Unit : g

Model	Flex type F	Joint type J	Linear type L	Remarks
<b>H</b>	113	113 (95)		Width: 25.4mm, length: 1m

( ) : aramid fiber cord products

The allowable tension only pertains to the tensile load and should not be used as part of the selection criteria. Please calculate the initial tension setting using the procedure provided on page 76. Provides numerical values for steel cords and aramid cords. Set the allowable tension for stainless-steel cords at 80% of the value provided in the table.

# Dimensions and specifications of trapezium teathed belts (inches)

# XH

This table provides the supported combinations of dimensions and specification with respect to Iron Rubber belts. Please contact us regarding any specifications not described in the table.

## Example of model dimension indication

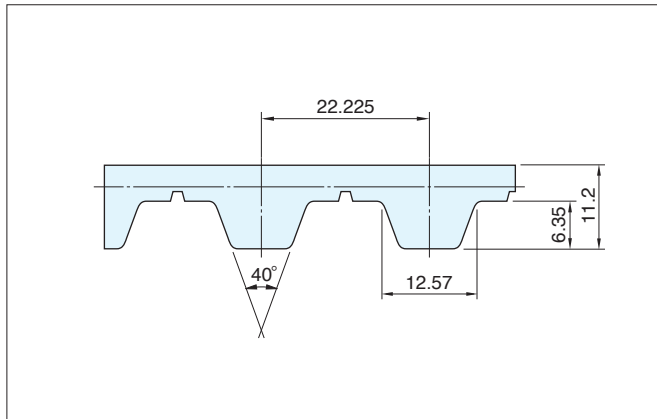

### 200-XH-0250E-FC1

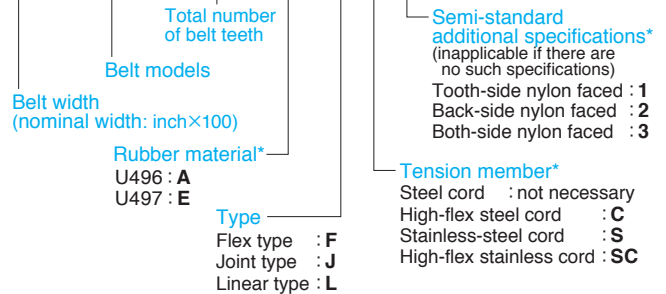

\*Please refer to the table below for the supported combinations of rubber material, tension member, and additional specifications.

Type	Belt width (Nominal width)		Length in mm (Number of teeth)
	mm		
<b>F</b> 	100	25.4	Minimum: 1355.73 (61) Maximum: 30003 (1350)
	150	38.1	
	200	50.8	
	300	76.2	
	400	101.6	

Additional specifications: symbol	Steel cord	High-flex steel cord	Stainless-steel cord	High-flex stainless cord
	Rubber material	Rubber material	Rubber material	Rubber material
	U497 (E)	U497 (E)	U497 (E)	U497 (E)
Without any additional specifications	<b>E-F</b>	<b>E-FC</b>	<b>E-FS</b>	<b>E-FSC</b>
Tooth-side nylon faced : 1	<b>E-F1</b>	<b>E-FC1</b>	<b>E-FS1</b>	<b>E-FSC1</b>

Type	Belt width (Nominal width)		Length in mm (Number of teeth)
	mm		
<b>J</b> 	100	25.4	Minimum: 1000.13 (45) Maximum: 25000 (1125)
	150	38.1	
	200	50.8	
	300	76.2	
	400	101.6	
<b>L</b> 	100	25.4	
	150	38.1	

Additional specifications: symbol	Steel cord	
	Rubber material	
	U496 (A)	U497 (E)
Without any additional specifications	<b>A-J</b> <b>A-L</b>	<b>E-J</b> <b>E-L</b>
Tooth-side nylon faced : 1	<b>A-J1</b> <b>A-L1</b>	—
Back-side nylon faced : 2	<b>A-J2</b> <b>A-L2</b>	—
Both-side nylon faced : 3	<b>A-J3</b> <b>A-L3</b>	—

Linear type belts have no minimum length.

## Allowable tension **F**

Unit : N

Belt width		Flex type <b>F</b>	Joint type <b>J</b>	Linear type <b>L</b>
Nominal width	mm			
100	25.4	2700	900	2340
150	38.1	4140	1800	3600
200	50.8	5400	2340	5040
300	76.2	8280	3780	7560
400	101.6	11200	4680	10080

The allowable tension only pertains to the tensile load and should not be used as part of the selection criteria.

Please calculate the initial tension setting using the procedure provided on page 76.

Provides numerical values for steel cords.

Set the allowable tension for stainless-steel cords at 80% of the value provided in the table.

## Product mass (reference value)

Unit : g

Model	Flex type <b>F</b>	Joint type <b>J</b>	Linear type <b>L</b>	Remarks
<b>XH</b>	268	260		Width: 25.4mm, length: 1m

# Dimensions and specifications of double sided teathed belts

## DT5

This table provides the supported combinations of dimensions and specification with respect to Iron Rubber belts. Please contact us regarding any specifications not described in the table.

### Example of model dimension indication

#### 010-DT5-0270E-FS1

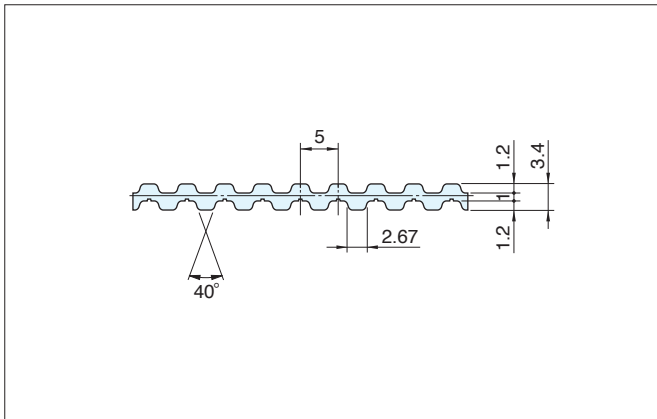
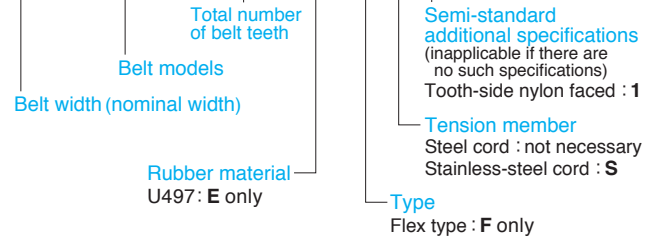

Type	Belt width (Nominal width)	Length in mm (Number of teeth)
<b>F</b> 	007	Minimum: 1350 (270)  Maximum: 10000 (2000)
	010	
	015	
	020	
	025	
	040	
	050	

Additional specifications: symbol	Steel cord	Stainless-steel cord
	Rubber material	Rubber material
	U497 (E)	U497 (E)
Without any additional specifications	<b>E-F</b>	<b>E-FS</b>
Tooth-side nylon faced : 1 (per side only)	<b>E-F1</b>	<b>E-FS1</b>

### Allowable tension **F**

Unit : N

Belt width mm	Flex type <b>F</b>
7	155
10	250
15	400
20	530
25	690
40	1140
50	1430

The allowable tension only pertains to the tensile load and should not be used as part of the selection criteria. Please calculate the initial tension setting using the procedure provided on page 76.

Provides numerical values for steel cords. Set the allowable tension for stainless-steel cords at 80% of the value provided in the table.

### Product mass (reference value)

Unit : g

Model	Flex type <b>F</b>	Joint type <b>J</b>	Linear type <b>L</b>	Remarks
<b>DT5</b>	79	—	—	Width: 25mm, length: 1m

# Dimensions and specifications of double sided teathed belts

# DT10

This table provides the supported combinations of dimensions and specification with respect to Iron Rubber belts. Please contact us regarding any specifications not described in the table.

## Example of model dimension indication

### 050-DT10-1500E-FS1

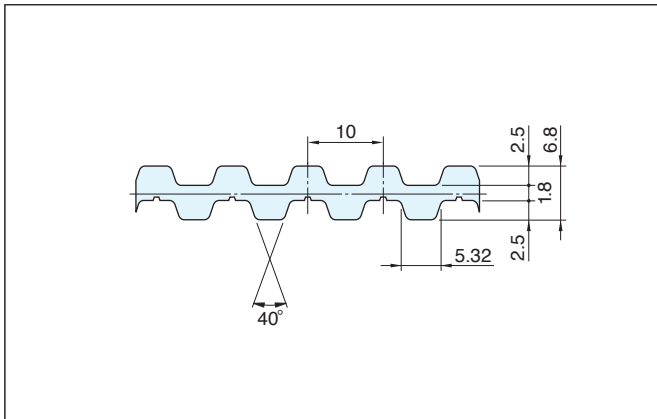
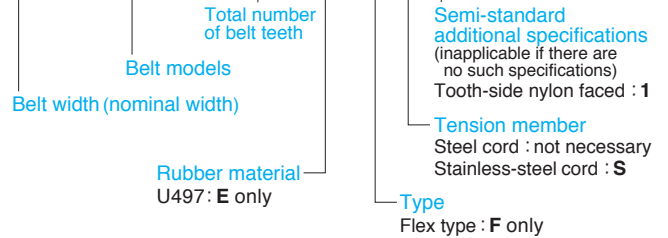

Type	Belt width (Nominal width)	Length in mm (Number of teeth)	Additional specifications: symbol	Steel cord		Stainless-steel cord	
				Rubber material	Rubber material	Rubber material	Rubber material
<b>F</b> 	015	Minimum: 1350 (135)  Maximum: 30000 (3000)	Without any additional specifications	U497 (E)		U497 (E)	
	020			<b>E-F</b>		<b>E-FS</b>	
	025		Tooth-side nylon faced : 1 (per side only)	<b>E-F1</b>		<b>E-FS1</b>	
	040			<b>E-F1</b>		<b>E-FS1</b>	
	050			<b>E-F1</b>		<b>E-FS1</b>	
	075			<b>E-F1</b>		<b>E-FS1</b>	
	100		<b>E-F1</b>		<b>E-FS1</b>		

## Allowable tension **F**

Unit: N

Belt width mm	Flex type <b>F</b>
10	—
15	790
20	1100
25	1420
40	2400
50	3040
75	4560
100	6160

The allowable tension only pertains to the tensile load and should not be used as part of the selection criteria. Please calculate the initial tension setting using the procedure provided on page 76.

Provides numerical values for steel cords.

Set the allowable tension for stainless-steel cords at 80% of the value provided in the table.

## Product mass (reference value)

Unit: g

Model	Flex type <b>F</b>	Joint type <b>J</b>	Linear type <b>L</b>	Remarks
<b>DT10</b>	157	—	—	Width: 25mm, length: 1m

# Dimensions and specifications of double sided teathed belts (inches)

# DH

This table provides the supported combinations of dimensions and specification with respect to Iron Rubber belts. Please contact us regarding any specifications not described in the table.

## Example of model dimension indication

### 075-DH-0250E-FS1

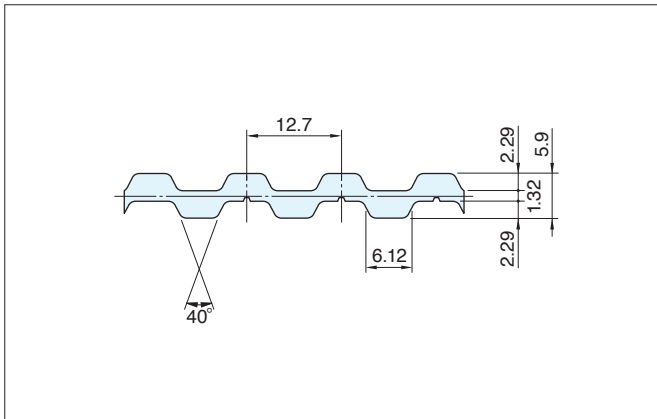
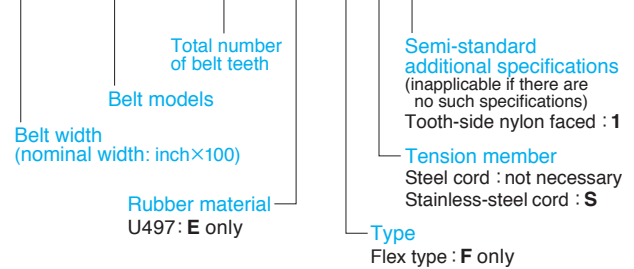

Type	Belt width (Nominal width)		Length in mm (Number of teeth)
		mm	
<b>F</b> 	075	19.1	Minimum: 1358.9 (107) Maximum: 30010 (2363)
	100	25.4	
	150	38.1	
	200	50.8	
	300	76.2	
	400	101.6	

Additional specifications: symbol	Steel cord	Stainless-steel cord
	Rubber material	Rubber material
	U497 (E)	U497 (E)
Without any additional specifications	<b>E-F</b>	<b>E-FS</b>
Tooth-side nylon faced : 1 (per side only)	<b>E-F1</b>	<b>E-FS1</b>

## Allowable tension F

Unit: N

Belt width		Flex type <b>F</b>
Nominal width	mm	
075	19.1	1040
100	25.4	1440
150	38.1	2240
200	50.8	3040
300	76.2	4640
400	101.6	6320

The allowable tension only pertains to the tensile load and should not be used as part of the selection criteria. Please calculate the initial tension setting using the procedure provided on page 76.

Provides numerical values for steel cords. Set the allowable tension for stainless-steel cords at 80% of the value provided in the table.

## Product mass (reference value)

Unit: g

Model	Flex type <b>F</b>	Joint type <b>J</b>	Linear type <b>L</b>	Remarks
<b>DH</b>	134	—	—	Width: 25.4mm, length: 1m



# Dimensions and specifications of self-tracking belts

## MA5-V

This table provides the supported combinations of dimensions and specification with respect to Iron Rubber belts. Please contact us regarding any specifications not described in the table.

### Example of model dimension indication

#### 050-MA5-2000E-LV1

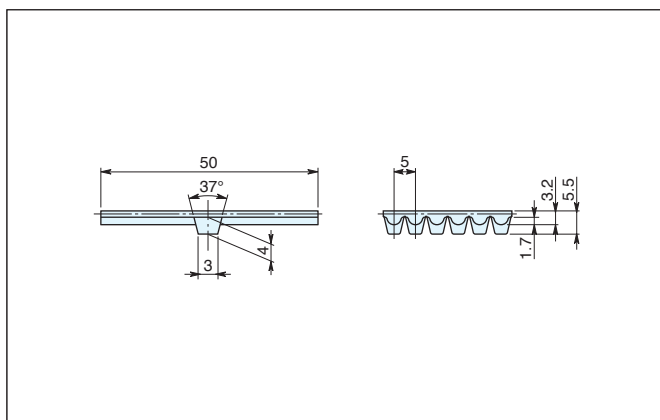
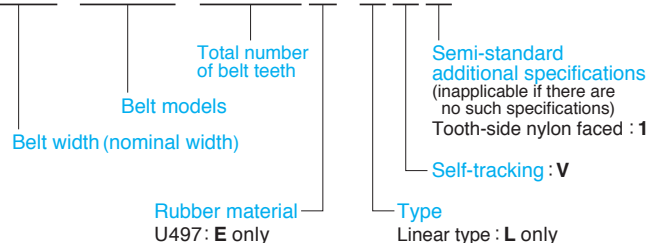

Type	Belt width (Nominal width)	Length in mm (Number of teeth)	Additional specifications: symbol	Steel cord
				Rubber material
	025 040 050	Maximum: 60000 (12000)	Without any additional specifications	U497 (E)
				<b>E-LV</b>
			Tooth-side nylon faced : 1	<b>E-LV1</b>

Maximum length of belts lined with fabric on the teeth-side is 40,000 (8,000). White fabric is used for any belts lined with fabric on the teeth-side.

### Allowable tension F

Unit: N

Belt width mm	Linear type L
25	1270
40	2010
50	2540

The allowable tension only pertains to the tensile load and should not be used as part of the selection criteria. Please calculate the initial tension setting using the procedure provided on page 76.

### Product mass (reference value)

Unit: g

Model	Flex type F	Joint type J	Linear type L	Remarks
<b>MA5-V</b>	—	—	95	Width: 25mm, length: 1m

# Dimensions and specifications of self-tracking belts



## AT10-V

This table provides the supported combinations of dimensions and specification with respect to Iron Rubber belts. Please contact us regarding any specifications not described in the table.

### Example of model dimension indication

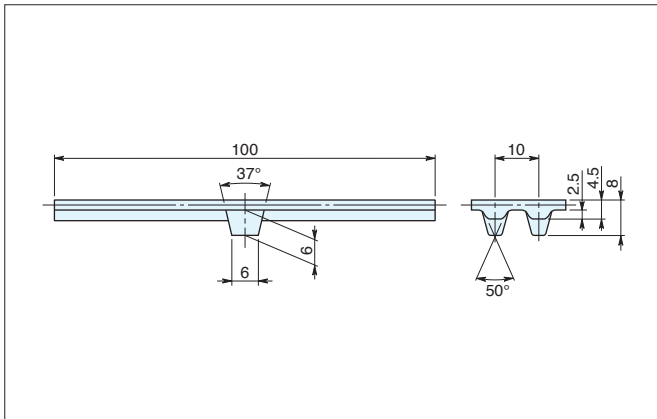
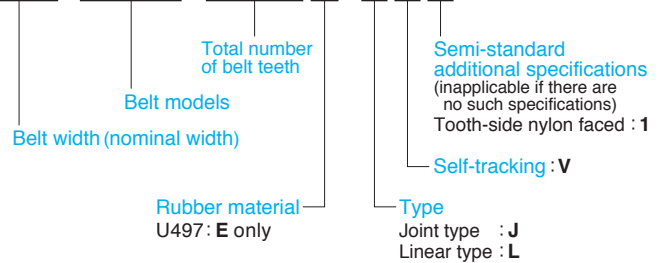
#### 025-AT10-1000E-JV1



Type	Belt width (Nominal width)	Length in mm (Number of teeth)	Additional specifications: symbol	Steel cord
				Rubber material
				U497 (E)
<b>J</b> 	025 040 050	Minimum: 930 (93)	Without any additional specifications	<b>E-JV, E-LV</b>
<b>L</b> 	075 100	Maximum: 40000 (4000)	Tooth-side nylon faced : 1	
				<b>E-JV1, E-LV1</b>

Linear type belts have no minimum length. Minimum number of pulley teeth is 20. White fabric is used for any belts lined with fabric on the teeth-side.

### Allowable tension F

Unit : N

Belt width mm	Joint type J	Linear type L
25	1000	2700
40	1800	4300
50	2100	5400
75	3600	8100
100	4600	10800

The allowable tension only pertains to the tensile load and should not be used as part of the selection criteria. Please calculate the initial tension setting using the procedure provided on page 76.

### Product mass (reference value)

Unit : g

Model	Flex type F	Joint type J	Linear type L	Remarks
<b>AT10-V</b>	—	160		Width: 25mm, length: 1m

# Dimensions and specifications of self-tracking belts



## T5-V

This table provides the supported combinations of dimensions and specification with respect to Iron Rubber belts. Please contact us regarding any specifications not described in the table.

### Example of model dimension indication

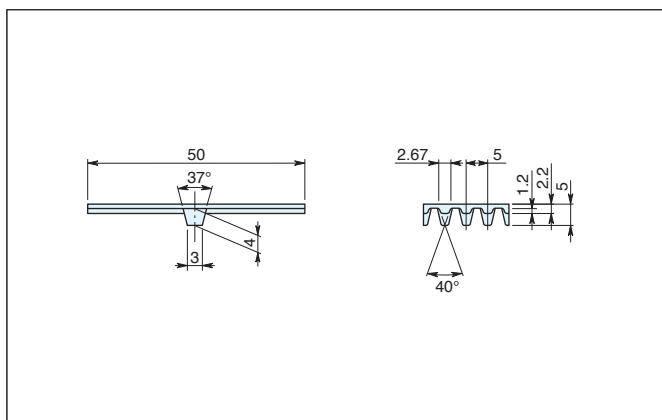
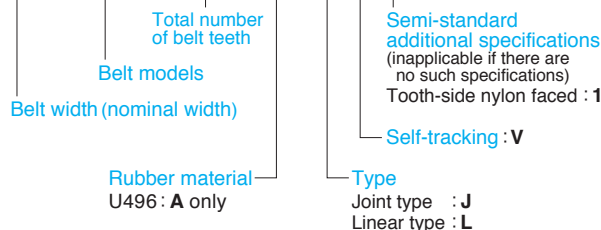
#### 030-T5-1000 A-JV1



Type	Belt width (Nominal width)	Length in mm (Number of teeth)	Additional specifications: symbol	Steel cord
				Rubber material
 <b>J</b>	030 040 050	Minimum: 465 (93)  Maximum: 30000 (6000)	Without any additional specifications	U496 (A)
				<b>A-JV, A-LV</b>
 <b>L</b>			Tooth-side nylon faced : 1	<b>A-JV1, A-LV1</b>

Linear type belts have no minimum length.  
 Minimum number of pulley teeth is 18.  
 White fabric is used for any belts lined with fabric on the teeth-side.

### Allowable tension F

Unit : N

Belt width mm	Joint type <b>J</b>	Linear type <b>L</b>
30	310	670
40	440	980
50	580	1250

The allowable tension only pertains to the tensile load and should not be used as part of the selection criteria. Please calculate the initial tension setting using the procedure provided on page 76.

### Product mass (reference value)

Unit : g

Model	Flex type <b>F</b>	Joint type <b>J</b>	Linear type <b>L</b>	Remarks
<b>T5-V</b>	—	50		Width: 25mm, length: 1m

# Dimensions and specifications of self-tracking belts

## T10-V

This table provides the supported combinations of dimensions and specification with respect to Iron Rubber belts. Please contact us regarding any specifications not described in the table.

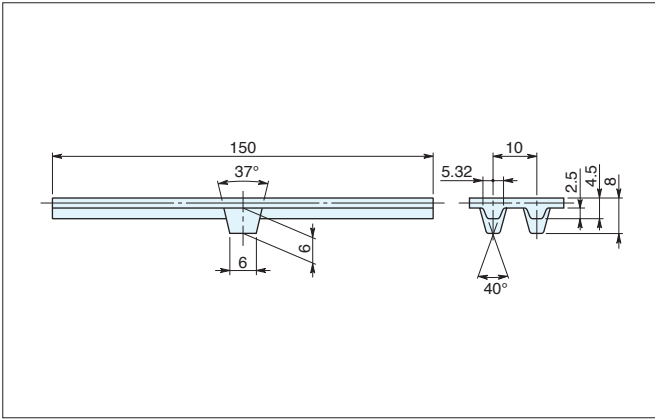

### Example of model dimension indication

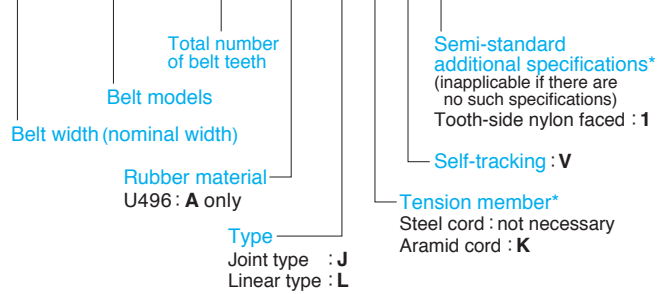

### 150-T10-1000A-JKV1



\*Please refer to the table below for the supported combinations of tension member and additional specifications.

Type	Belt width (Nominal width)	Length in mm (Number of teeth)
<b>J</b> 	050 075 100	Minimum: 730 (73)
<b>L</b> 	125 150	Maximum: 40000 (4000)

Additional specifications: symbol	Steel cord	Aramid cord
	Rubber material U496 (A)	Rubber material U496 (A)
Without any additional specifications	<b>A-JV</b> <b>A-LV</b>	<b>A-JKV</b> <b>A-LKV</b>
Tooth-side nylon faced : 1	<b>A-JV1</b> <b>A-LV1</b>	—

Linear type belts have no minimum length. Minimum number of pulley teeth is 20. White fabric is used for any belts lined with fabric on the teeth-side.

### Allowable tension F

Unit : N

Belt width mm	Joint type J	Linear type L
50	640	1600
75	1100	2400
100	1600	3300
125	1900	4100
150	2400	5120

The allowable tension only pertains to the tensile load and should not be used as part of the selection criteria. Please calculate the initial tension setting using the procedure provided on page 76. Provides numerical values for steel cords and aramid cords.

### Product mass (reference value)

Unit : g

Model	Flex type F	Joint type J	Linear type L	Remarks
<b>T10-V</b>	—	118 (106)		Width: 25mm, length: 1m

( ): aramid fiber cord products

# Dimensions and specifications of self-tracking belts (inches)

# L-V

This table provides the supported combinations of dimensions and specification with respect to Iron Rubber belts. Please contact us regarding any specifications not described in the table.

## Example of model dimension indication

### 100-L-2000A-JV

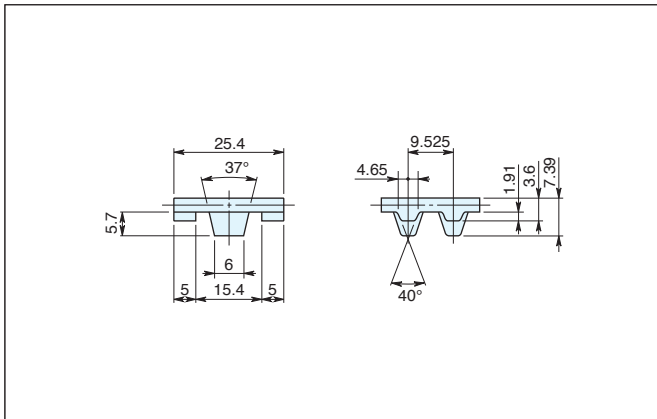
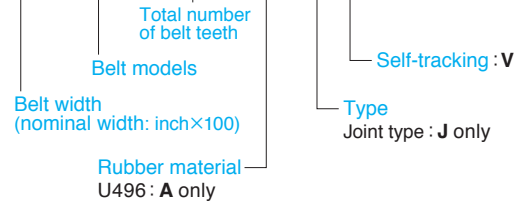

Type	Belt width (Nominal width)		Length in mm (Number of teeth)	Additional specifications: symbol	Steel cord
	mm				Rubber material
	100	25.4	Minimum: 895.35 (94) Maximum: 40005 (4200)	Without any additional specifications	U496 (A)
					<b>A-JV</b>

Please contact us, when a linear type is required. Minimum number of pulley teeth is 15.

## Allowable tension F

Unit: N

Belt width		Joint type J
Nominal width	mm	
100	25.4	320

The allowable tension only pertains to the tensile load and should not be used as part of the selection criteria. Please calculate the initial tension setting using the procedure provided on page 76.

## Product mass (reference value)

Unit: g

Model	Flex type F	Joint type J	Linear type L	Remarks
L-V	—	91	—	Width: 25.4mm, length: 1m

# Dimensions and specifications of wide toothed belts

## Wide T10

This table provides the supported combinations of dimensions and specification with respect to Iron Rubber belts. Please contact us regarding any specifications not described in the table.

### Example of model dimension indication

#### 300-T10-0250 E-JK5

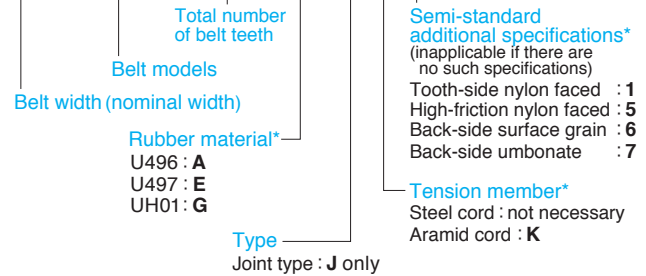

\*Please refer to the table below for the supported combinations of rubber material, tension member, and additional specifications.

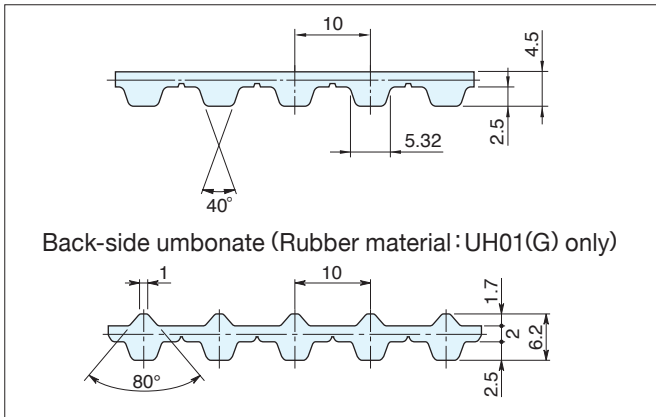

Type	Belt width (Nominal width)	Length in mm (Number of teeth)	Additional specifications: symbol	Steel cord		Aramid cord		
				Rubber material		Rubber material		
				U496 (A)	U497 (E)	U496 (A)	U497 (E)	UH01 (G)
<b>J</b> 	150	Minimum: 700 (70) Maximum: 50000 (5000)	Without any additional specifications	<b>A-J</b>	—	<b>A-JK</b>	<b>E-JK</b>	<b>G-JK</b>
			Tooth-side nylon faced : 1	<b>A-J1</b>	—	—	—	—
			High-friction nylon faced : 5	<b>A-J5</b>	—	—	—	—
			Back-side surface grain : 6	<b>A-J6</b>	—	<b>A-JK6</b>	—	—
	200 250 300 350 400	(Back-side umbonate only) Minimum: 790 (79) Maximum: 50000 (5000)	Without any additional specifications	—	—	—	<b>E-JK</b>	<b>G-JK</b>
			High-friction nylon faced : 5	—	—	—	<b>E-JK5</b>	—
			Back-side surface grain : 6	—	—	—	<b>E-JK6</b>	—
			Back-side umbonate : 7	—	—	—	—	<b>G-JK7</b>
			—	—	—	—	—	—
			—	—	—	—	—	—

Please contact us, when a linear type is required.

For high-friction nylon faced belts, the thickness is 0.5mm and the total height is 5.0mm (minimum number of pulley teeth: 20 teeth). Maximum length of belts with a rear surface grain: 40,000 (4,000)

### Allowable tension F

Unit: N

Belt width mm	Joint type J
150	2400
200	1100
250	1370
300	1650
350	1920
400	2200

The allowable tension only pertains to the tensile load and should not be used as part of the selection criteria. Please calculate the initial tension setting using the procedure provided on page 76.

Provides numerical values for steel cords and aramid cords.

### Product mass (reference value)

Unit: g

Model	Flex type F	Joint type J	Linear type L	Remarks
<b>T10</b>	—	102 (92)	—	Width: 25mm, length: 1m

( ): aramid fiber cord products

# Dimensions and specifications of wide toothed belts (inches)

## Wide H

This table provides the supported combinations of dimensions and specification with respect to Iron Rubber belts. Please contact us regarding any specifications not described in the table.

### Example of model dimension indication

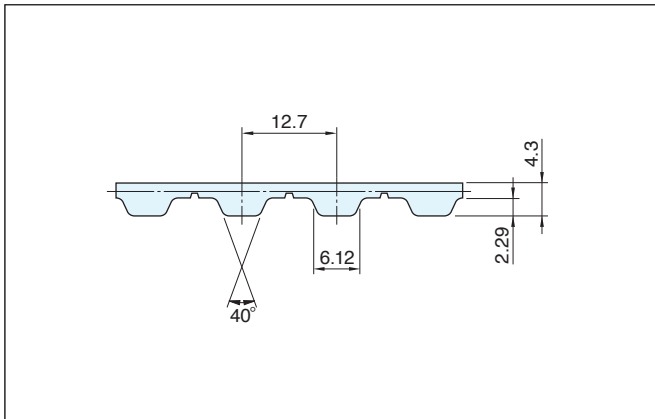

### 500-H-0250A-JK1

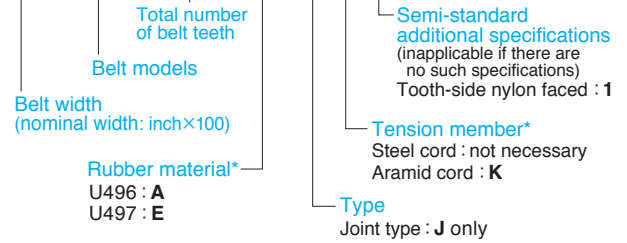

Type	Belt width (Nominal width)		Length in mm (Number of teeth)
	mm		
	500	127.0	Minimum: 850.9 (67)
	600	152.4	Maximum: 40005 (3150)

Additional specifications: symbol	Steel cord		Aramid cord	
	Rubber material		Rubber material	
	U496 (A)	U497 (E)	U496 (A)	U497 (E)
Without any additional specifications	A-J	E-J	A-JK	—
Tooth-side nylon faced : 1	A-J1	—	A-JK1	—

Please contact us, when a linear type is required.

### Allowable tension F

Unit : N

Belt width		Joint type J
Nominal width	mm	
500	127.0	2030
600	152.4	2560

The allowable tension only pertains to the tensile load and should not be used as part of the selection criteria. Please calculate the initial tension setting using the procedure provided on page 76. Provides numerical values for steel cords and aramid cords.

### Product mass (reference value)

Unit : g

Model	Flex type F	Joint type J	Linear type L	Remarks
H	—	111 (95)	—	Width: 25.4mm, length: 1m

( ) : aramid fiber cord products

# Dimensions and specifications of flat belts

## F12

This table provides the supported combinations of dimensions and specification with respect to Iron Rubber belts. Please contact us regarding any specifications not described in the table.

### Example of model dimension indication

#### 025-F12-2500A-FS

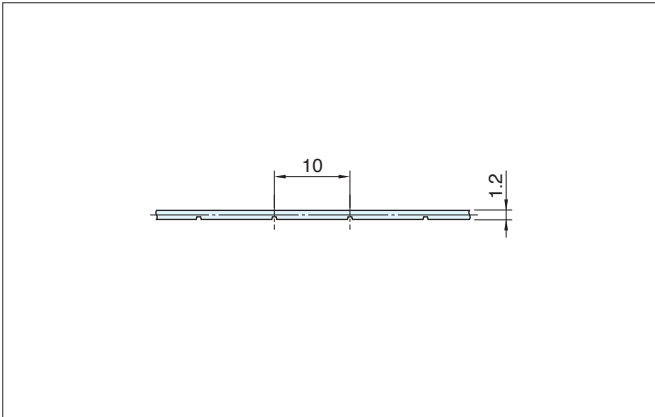
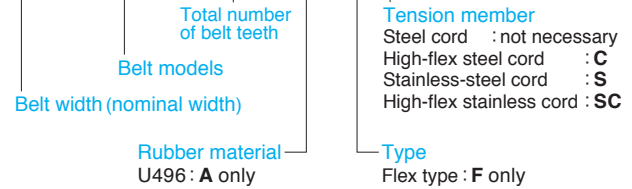

Type	Belt width (Nominal width)	Length in mm (Number of teeth)	Additional specifications: symbol	Steel cord	High-flex steel cord	Stainless-steel cord	High-flex stainless cord
				Rubber material	Rubber material	Rubber material	Rubber material
				U496 (A)	U496 (A)	U496 (A)	U496 (A)
<b>F</b> 	010	Minimum: 1500 Maximum: 10000	Without any additional specifications	<b>A-F</b>	<b>A-FC</b>	<b>A-FS</b>	<b>A-FSC</b>
	015						
	020						
	025						
	040						
	050						

Please ensure to specify a belt length that is equal to or longer than the minimum length and in multiples of 10mm. The minimum pulley diameter is  $\phi 20$ .

### Allowable tension F

Unit: N

Belt width mm	Flex type <b>F</b>
10	250
15	400
20	530
25	690
40	1140
50	1430

The allowable tension only pertains to the tensile load and should not be used as part of the selection criteria. Provides numerical values for steel cords. Set the allowable tension for stainless-steel cords at 80% of the value provided in the table.

### Product mass (reference value)

Unit: g

Model	Flex type <b>F</b>	Joint type <b>J</b>	Linear type <b>L</b>	Remarks
<b>F12</b>	44	—	—	Width: 25mm, length: 1m



# Dimensions and specifications of flat belts

## F20

This table provides the supported combinations of dimensions and specification with respect to Iron Rubber belts. Please contact us regarding any specifications not described in the table.

### Example of model dimension indication

#### 025-F20-2500A-FS

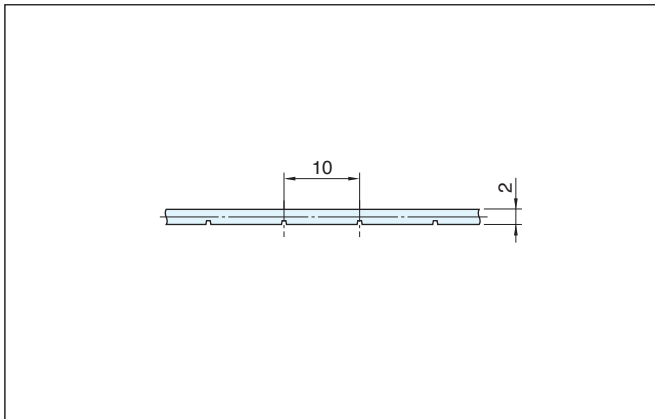
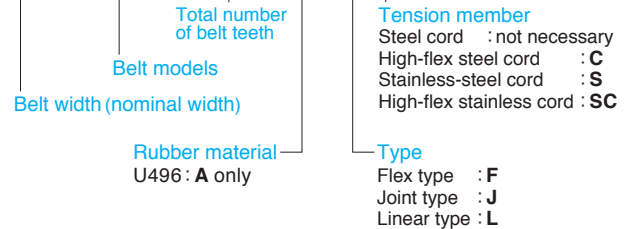

Type	Belt width (Nominal width)	Length in mm (Number of teeth)	Additional specifications: symbol	Steel cord	High-flex steel cord	Stainless-steel cord	High-flex stainless cord
				Rubber material	Rubber material	Rubber material	Rubber material
 <b>F</b>	015	Minimum: 1500 Maximum: 24000	Without any additional specifications	U496 ( <b>A</b> )	U496 ( <b>A</b> )	U496 ( <b>A</b> )	U496 ( <b>A</b> )
	020			<b>A-F</b>	<b>A-FC</b>	<b>A-FS</b>	<b>A-FSC</b>
	025						
	040						
	050						
	100						

Please ensure to specify a belt length that is equal to or longer than the minimum length and in multiples of 10mm. The minimum pulley diameter is  $\phi 50$ .

Type	Belt width (Nominal width)	Length in mm (Number of teeth)	Additional specifications: symbol	Steel cord		
				Rubber material	U496 ( <b>A</b> )	
 <b>J</b>   <b>L</b>	015	Minimum: 800 Maximum: 50000	Without any additional specifications			
	020			<b>A-J</b>		
	025					
	040					
	050					
	100					

Please ensure to specify a belt length that is equal to or longer than the minimum length and in multiples of 10mm. The minimum pulley diameter is  $\phi 50$ . Linear type belts have no minimum length.

### Allowable tension **F**

Unit : N

Belt width mm	Flex type <b>F</b>	Joint type <b>J</b>	Linear type <b>L</b>
10	—	—	470
15	790	190	640
20	1100	250	880
25	1420	510	1280
40	2400	760	1920
50	3040	1020	2560
75	4560	1530	3840
100	6160	2050	5120

### Product mass (reference value)

Unit : g

Model	Flex type <b>F</b>	Joint type <b>J</b>	Linear type <b>L</b>	Remarks
<b>F20</b>	77	75		Width: 25mm, length: 1m

The allowable tension only pertains to the tensile load and should not be used as part of the selection criteria. Provides numerical values for steel cords. Set the allowable tension for stainless-steel cords at 80% of the value provided in the table.

# Dimensions and specifications of flat belts

## F60

This table provides the supported combinations of dimensions and specification with respect to Iron Rubber belts. Please contact us regarding any specifications not described in the table.

### Example of model dimension indication

#### 025-F60-2500D-FS

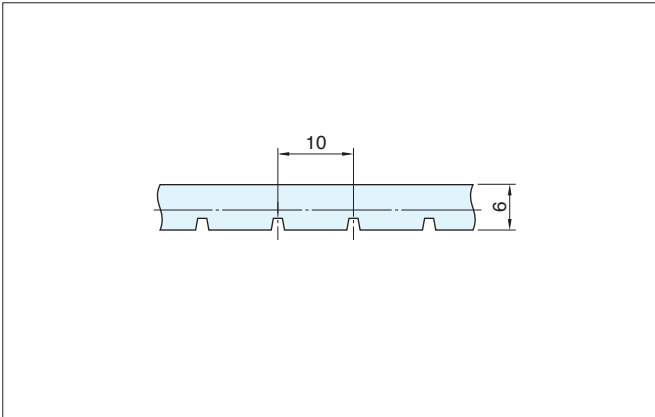
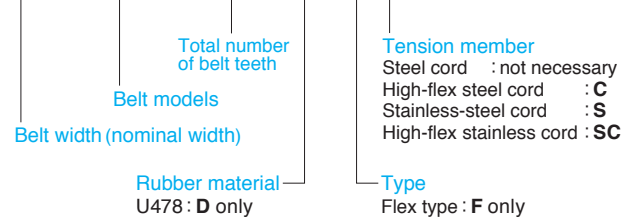

Type	Belt width (Nominal width)	Length in mm (Number of teeth)	Additional specifications: symbol	Steel cord	High-flex steel cord	Stainless-steel cord	High-flex stainless cord
				Rubber material	Rubber material	Rubber material	Rubber material
				U478 (D)	U478 (D)	U478 (D)	U478 (D)
<b>F</b> 	015	Minimum: 1500 Maximum: 24000	Without any additional specifications	<b>D-F</b>	<b>D-FC</b>	<b>D-FS</b>	<b>D-FSC</b>
	020						
	025						
	040						
	050						
	075						
	100						

Please ensure to specify a belt length that is equal to or longer than the minimum length and in multiples of 10mm. The minimum pulley diameter is  $\phi 100$ .

### Allowable tension F

Unit: N

Belt width mm	Flex type F
15	790
20	1100
25	1420
40	2400
50	3040
75	4560
100	6160

The allowable tension only pertains to the tensile load and should not be used as part of the selection criteria. Provides numerical values for steel cords. Set the allowable tension for stainless-steel cords at 80% of the value provided in the table.

### Product mass (reference value)

Unit: g

Model	Flex type F	Joint type J	Linear type L	Remarks
<b>F60</b>	198	—	—	Width: 25mm, length: 1m

# Dimensions and specifications of self-tracking flat belts

## F10-V

This table provides the supported combinations of dimensions and specification with respect to Iron Rubber belts. Please contact us regarding any specifications not described in the table.

### Example of model dimension indication

#### 006-F10-1000E-JV

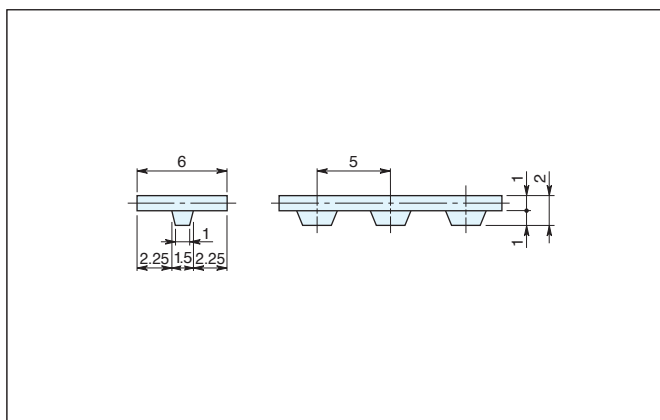
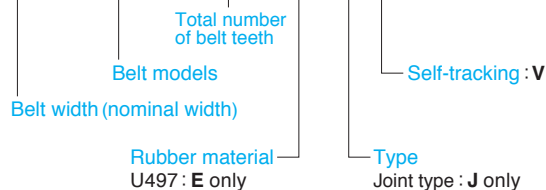

Type	Belt width (Nominal width)	Length in mm (Number of teeth)	Additional specifications: symbol	Steel cord
				Rubber material
	006	Minimum: 850 Maximum: 60000	Without any additional specifications	U497 (E)
				E-JV

Please ensure to specify a belt length that is equal to or longer than the minimum length and in multiples of 5mm. The minimum pulley diameter is  $\phi 15$ .

### Allowable tension F

Unit: N

Belt width mm	Joint type J
6	40

The allowable tension only pertains to the tensile load and should not be used as part of the selection criteria.

### Product mass (reference value)

Unit: g

Model	Flex type F	Joint type J	Linear type L	Remarks
F10-V	—	9	—	Width: 6mm, length: 1m

# Dimensions and specifications of self-tracking flat belts

## F20-V

This table provides the supported combinations of dimensions and specification with respect to Iron Rubber belts. Please contact us regarding any specifications not described in the table.

### Example of model dimension indication

#### 040-F20-1000A-JV

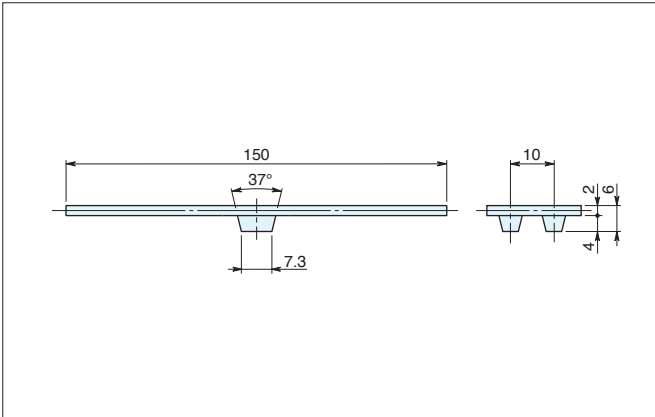
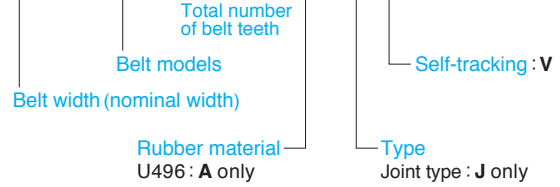

Type	Belt width (Nominal width)	Length in mm (Number of teeth)	Additional specifications: symbol	Steel cord
				Rubber material
	040	Minimum: 900 Maximum: 50000	Without any additional specifications	U496 (A)
	050			<b>A-JV</b>
	075			
	100			
	125			
	150			

Please ensure to specify a belt length that is equal to or longer than the minimum length and in multiples of 10mm. The minimum pulley diameter is  $\phi 50$ .

### Allowable tension F

Unit: N

Belt width mm	Joint type J
40	540
50	680
75	1020
100	1350
125	1700
150	2050

The allowable tension only pertains to the tensile load and should not be used as part of the selection criteria.

### Product mass (reference value)

Unit: g

Model	Flex type F	Joint type J	Linear type L	Remarks
F20-V	—	78	—	Width: 25mm, length: 1m

# Dimensions and specifications of double width teathed belts

## AT10

Please note that grooves in the pulleys and guide rails will be needed as burrs get generated with heat-welds on the backsides and teeth side.

### Example of model dimension indication

#### 200-AT10-1350E-FC1Y

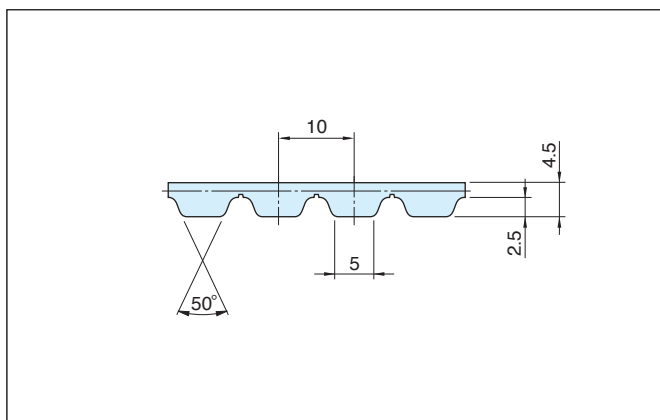
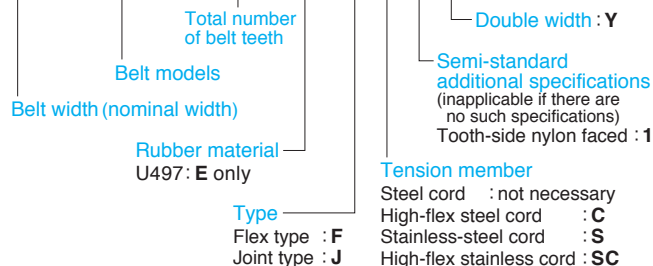

Type	Belt width (Nominal width)	Length in mm (Number of teeth)
<b>F</b> 	200	Minimum: 2500 (250) Maximum: 30000 (3000)

Additional specifications: symbol	Steel cord	High-flex steel cord	Stainless-steel cord	High-flex stainless cord
	Rubber material U497 (E)	Rubber material U497 (E)	Rubber material U497 (E)	Rubber material U497 (E)
Double width: Y	<b>E-FY</b>	<b>E-FCY</b>	<b>E-FSY</b>	<b>E-FSCY</b>
Tooth-side nylon faced: 1 + Double width: Y	<b>E-F1Y</b>	<b>E-FC1Y</b>	<b>E-FS1Y</b>	<b>E-FSC1Y</b>

Type	Belt width (Nominal width)	Length in mm (Number of teeth)
<b>J</b> 	200	Minimum: 2500 (250) Maximum: 40000 (4000)

Additional specifications: symbol	Steel cord
	Rubber material U497 (E)
Double width: Y	<b>E-JY</b>

Attention: Ensure not to use backlash-less pulleys.

### Allowable tension F

Unit: N

Belt width mm	Flex type F	Joint type J
200	23400	10000

The allowable tension only pertains to the tensile load and should not be used as part of the selection criteria. Provides numerical values for steel cords. Set the allowable tension for stainless-steel cords at 80% of the value provided in the table.

### Product mass (reference value)

Unit: g

Model	Flex type F	Joint type J	Linear type L	Remarks
<b>AT10</b>	150	150	—	Width: 25mm, length: 1m

# Dimensions and specifications of double width teathed belts

## T10

Please note that grooves in the pulleys and guide rails will be needed as burrs get generated with heat-welds on the backsides and teeth side.

### Example of model dimension indication

#### 200-T10-1350E-FC1Y

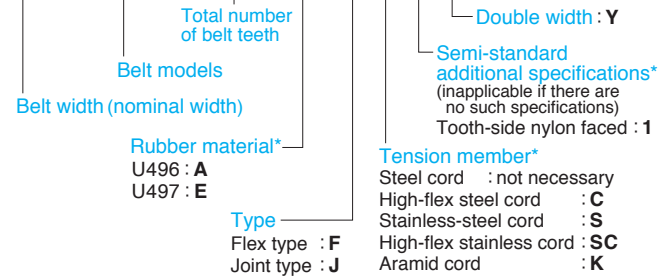

\*Please refer to the table below for the supported combinations of rubber material, tension member, and additional specifications.

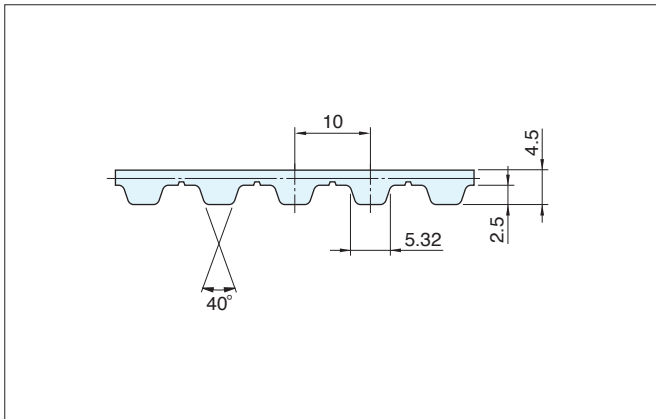

Type	Belt width (Nominal width)	Length in mm (Number of teeth)	Additional specifications: symbol	Steel cord	High-flex steel cord	Stainless-steel cord	High-flex stainless cord
				Rubber material	Rubber material	Rubber material	Rubber material
				U497 (E)	U497 (E)	U497 (E)	U497 (E)
 F	200	Minimum: 2500 (250) Maximum: 30000 (3000)	Double width: Y	E-FY	E-FCY	E-FSY	E-FSCY
			Tooth-side nylon faced: 1 + Double width: Y	E-F1Y	E-FC1Y	E-FS1Y	E-FSC1Y

Type	Belt width (Nominal width)	Length in mm (Number of teeth)	Additional specifications: symbol	Steel cord		Aramid cord	
				Rubber material		Rubber material	
				U496 (A)	U497 (E)	U496 (A)	U497 (E)
 J	200	Minimum: 2500 (250) Maximum: 50000 (5000)	Double width: Y	A-JY	E-JY	A-JKY	E-JKY
	300		Double width: Y	A-JY	—	A-JKY	E-JKY
	500 600 700 800		Double width: Y	—	—	—	E-JKY

### Allowable tension F

Unit: N

Belt width mm	Flex type F	Joint type J
200	12320	5120
300	—	4800
500	—	2740
600	—	3300
700	—	3840
800	—	4400

The allowable tension only pertains to the tensile load and should not be used as part of the selection criteria. Please calculate the initial tension setting using the procedure provided on page 76.

Provides numerical values for steel cords and aramid cords. Set the allowable tension for stainless-steel cords at 80% of the value provided in the table.

### Product mass (reference value)

Unit: g

Model	Flex type F	Joint type J	Linear type L	Remarks
T10	110	102 (92)	—	Width: 25mm, length: 1m

( ): aramid fiber cord products

# Dimensions and specifications of double width toothed belts (inches)

# H

Please note that grooves in the pulleys and guide rails will be needed as burrs get generated with heat-welds on the backsides and teeth side.

## Example of model dimension indication

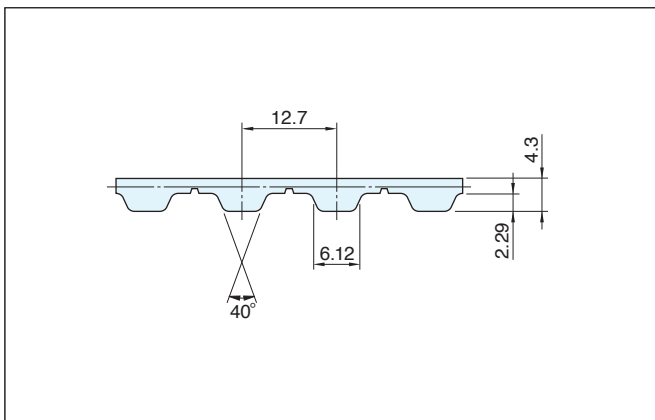

### 800-H-1350E-FC1Y

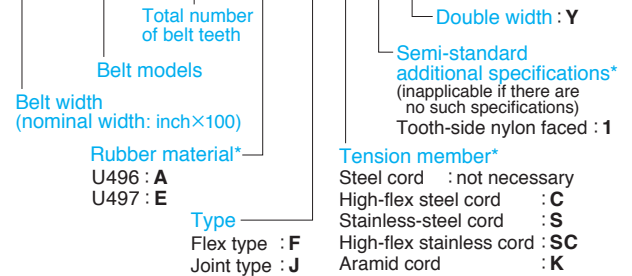

\*Please refer to the table below for the supported combinations of rubber material, tension member, and additional specifications.

Type	Belt width (Nominal width)		Length in mm (Number of teeth)
	mm	mm	
<b>F</b> 	800	203.2	Minimum: 2540 (200) Maximum: 30010 (2363)

Additional specifications: symbol	Steel cord	High-flex steel cord	Stainless-steel cord	High-flex stainless cord
	Rubber material	Rubber material	Rubber material	Rubber material
	U497 (E)	U497 (E)	U497 (E)	U497 (E)
Double width : Y	<b>E-FY</b>	<b>E-FCY</b>	<b>E-FSY</b>	<b>E-FSCY</b>
Tooth-side nylon faced : 1 + Double width : Y	<b>E-F1Y</b>	<b>E-FC1Y</b>	<b>E-FS1Y</b>	<b>E-FSC1Y</b>

Type	Belt width (Nominal width)		Length in mm (Number of teeth)
	mm	mm	
<b>J</b> 	800	203.2	Minimum: 2540 (200) Maximum: 40005 (3150)
	1000	254.0	
	1200	304.8	

Additional specifications: symbol	Steel cord		Aramid cord	
	Rubber material		Rubber material	
	U496 (A)	U497 (E)	U496 (A)	U497 (E)
Double width : Y	<b>A-JY</b>	<b>E-JY</b>	<b>A-JKY</b>	<b>E-JKY</b>
Double width : Y	<b>A-JY</b>	<b>E-JY</b>	<b>A-JKY</b>	—

## Allowable tension F

Unit : N

Belt width		Flex type <b>F</b>	Joint type <b>J</b>
Nominal width	mm		
800	203.2	12640	5120
1000	254.0	—	4060
1200	304.8	—	5120

The allowable tension only pertains to the tensile load and should not be used as part of the selection criteria. Please calculate the initial tension setting using the procedure provided on page 76.

Provides numerical values for steel cords and aramid cords. Set the allowable tension for stainless-steel cords at 80% of the value provided in the table.

## Product mass (reference value)

Unit : g

Model	Flex type <b>F</b>	Joint type <b>J</b>	Linear type <b>L</b>	Remarks
<b>H</b>	113	111 (95)	—	Width: 25.4mm, length: 1m

( ) : aramid fiber cord products

## Free Attachment belts

# FAT belt

This table provides the supported combinations of dimensions and specification with respect to Iron Rubber belts. Please contact us regarding any specifications not described in the table.

## Characteristics of the product

Spot-faced holes for nuts require one-piece molds.

- Any attachments that are supported by the conveyor can be mounted in any position.

Utilizes the implant system for the nuts.

- Ensures the secure mounting of attachments.
- The belt teeth shape is the same as that of the AT10 and the standard AT10 pulley can be used.

Utilizes the bolt system.

- Simplifies the mounting of attachments.

Note) Please note that the bolts and attachments are not provided. The dedicated nuts supplied with the product are required when mounting anything.

Iron Rubber teathed belts include the following features.

- Synchronous conveyor,
- Superior abrasion resistance,
- Superior mechanical strength, and
- Superior ozone resistance

Joint types include the following features.

- High-tensile steel cords get implanted in parallel and in a one-piece Iron Rubber mold process.
- The molding process is used with any endless teathed belts 960mm or longer.

Fabric-faced belts provide the following features.

- Reduced conveyor load.
- Reduced conveyance noise.

## Dimensions of spot-faced holes for use with attachments/Bolt length

Bolt lengths can be roughly calculated using the thickness of the attachment + 4.5mm.

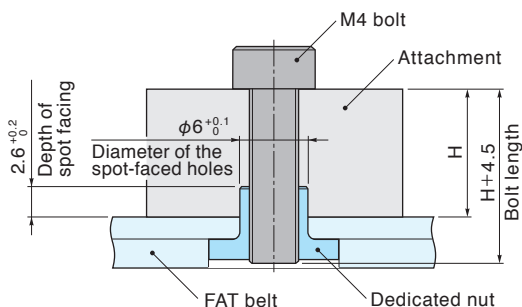

- Ensure to avoid any excessive tightening of the bolts. (Reference torque value: 0.2 ~ 0.5Nm)  
Any excessive tightening of the bolts could warp the belt, loosen the nuts, or lead to other problems.
- If the bolts do loosen please ensure to use a preventative agent.
- Please appropriately adjust in preventing the edges of the bolts from protruding from the belt.

## Product shape

### [Backside of belt]

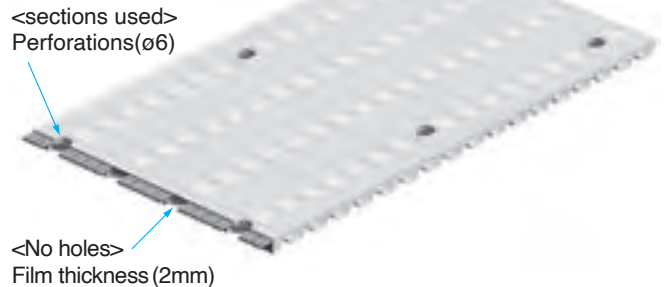

### [Belt tooth-side]



## How to mount the attachment

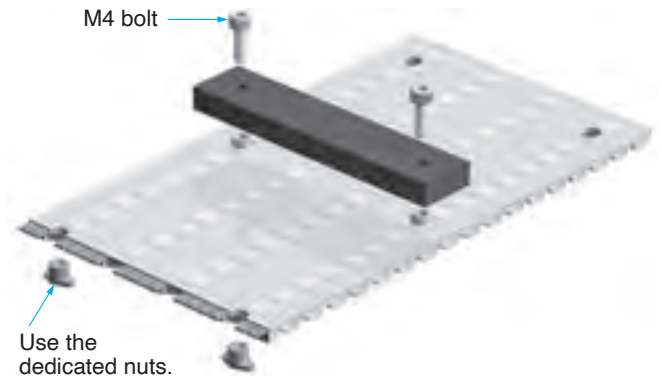

## Dedicated nut

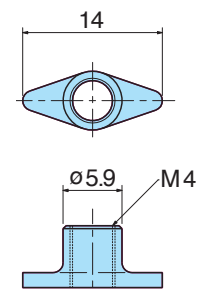

- Brass used as the standard material. (Brass is utilized unless specified Unless specified, the material is brass)
- We can also provide stainless-steel nuts.



# FAT

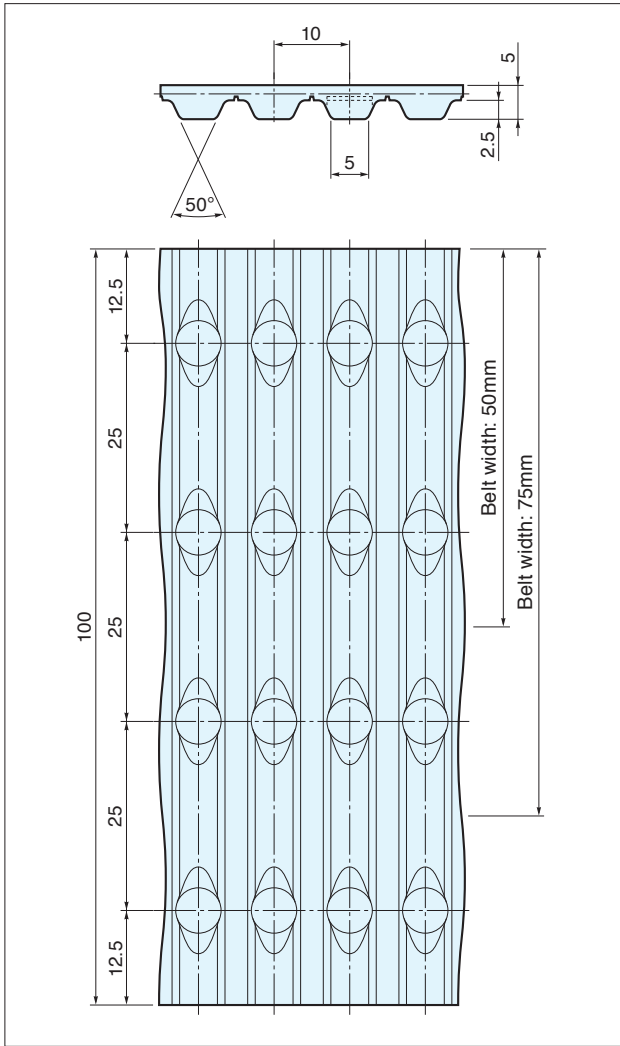

## Example of model dimension indication

**050-FAT1-2000E-J3Y**

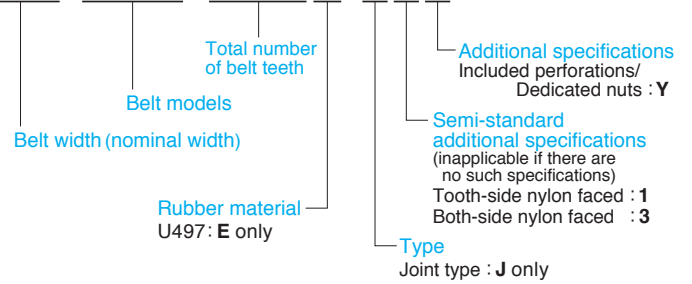

**Additional specifications : Y**  
 Included perforations/Dedicated nuts

Please ensure to inform us of the pitch if any perforations are needed to mount any attachments. (Please also inform us if no perforations are needed.)  
 Please ensure to inform us of the necessary quantity of dedicated nuts. (If no specific instructions are received then the quantity will be the same number as the number of perforations.)

Type	Belt width (Nominal width)	Length in mm (Number of teeth)	Additional specifications: symbol	Steel cord
				Rubber material
<b>J</b> 	050 075 100	Minimum: 960 (96) Maximum: 40000 (4000)	Without any additional specifications	<b>E-JY</b>
			Tooth-side nylon faced : 1	<b>E-J1Y</b>
			Both-side nylon faced : 3	<b>E-J3Y</b>

White fabric is used for any belts lined with fabric on the teeth-side.

## Allowable tension F

Unit : N

Belt width mm	Joint type J
50	1000
75	1500
100	2000

## Pulley

The minimum pulley diameter is 25.

•Utilizes the same pulley as the AT10.

# Profile

Individual profiles (attachments) can be provided to Iron Rubber toothed belts via heat-molding in thus fulfilling multiple functionality in the fields of conveyance and operating devices and the following usages.

- Positioning
- Switching
- Separation
- Timing

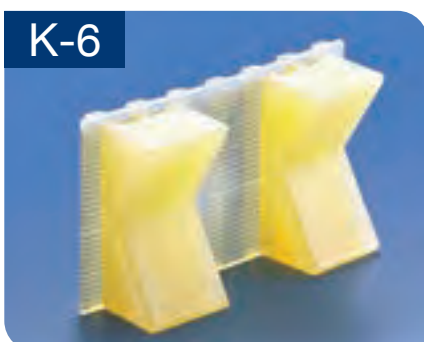
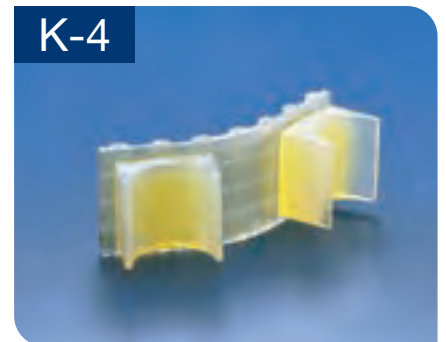
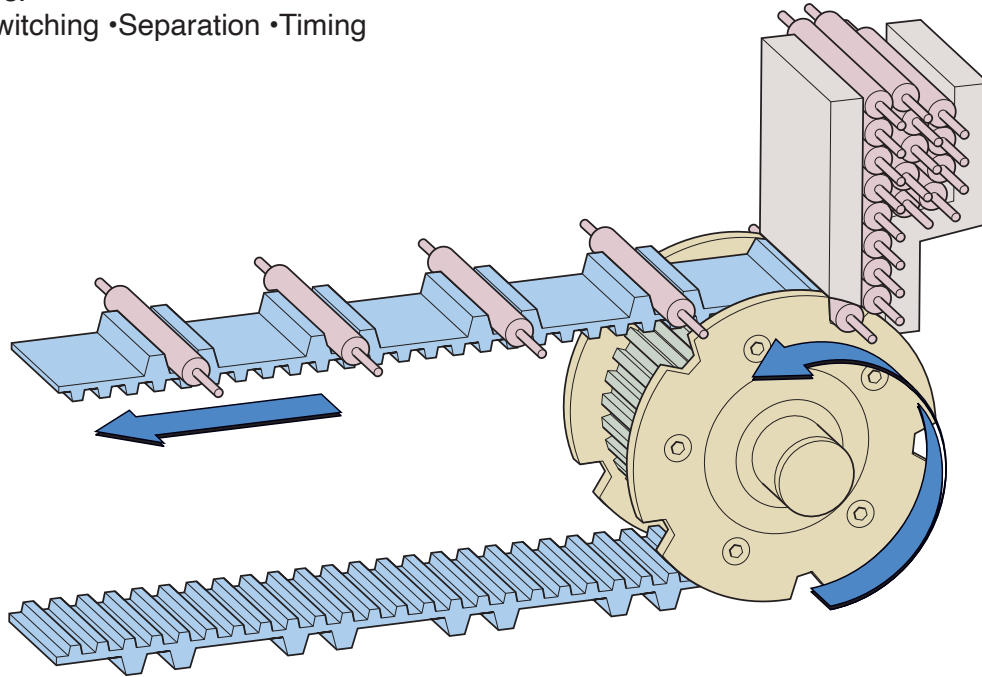

Please refer to pages 60 to 74 for more details on profile dimensions.

Various profiles supported. Please refer to the profile dimensions table for the different shapes and dimensions available.  
 Please contact us in any case where a standard product will not meet the conditions of use as we can machine or manufacture profiles using dedicated molds.

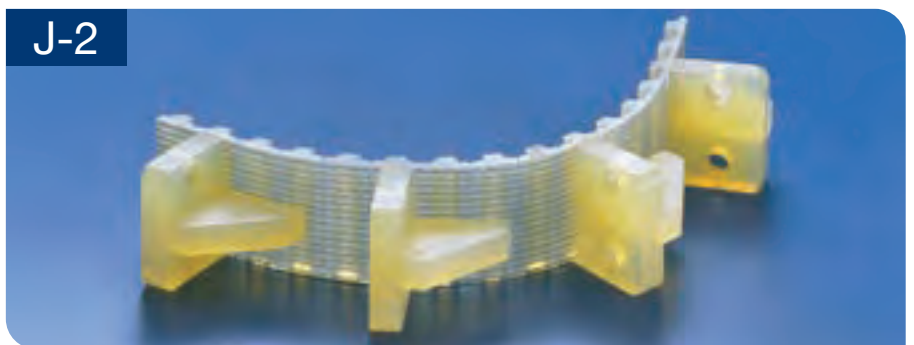
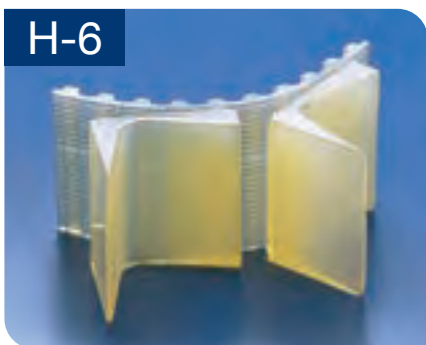
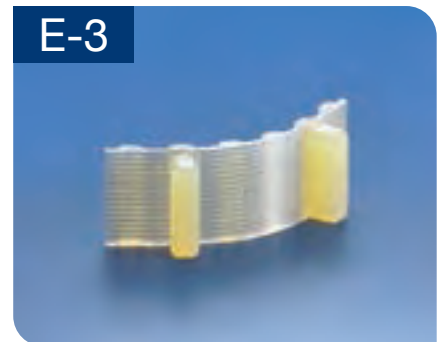
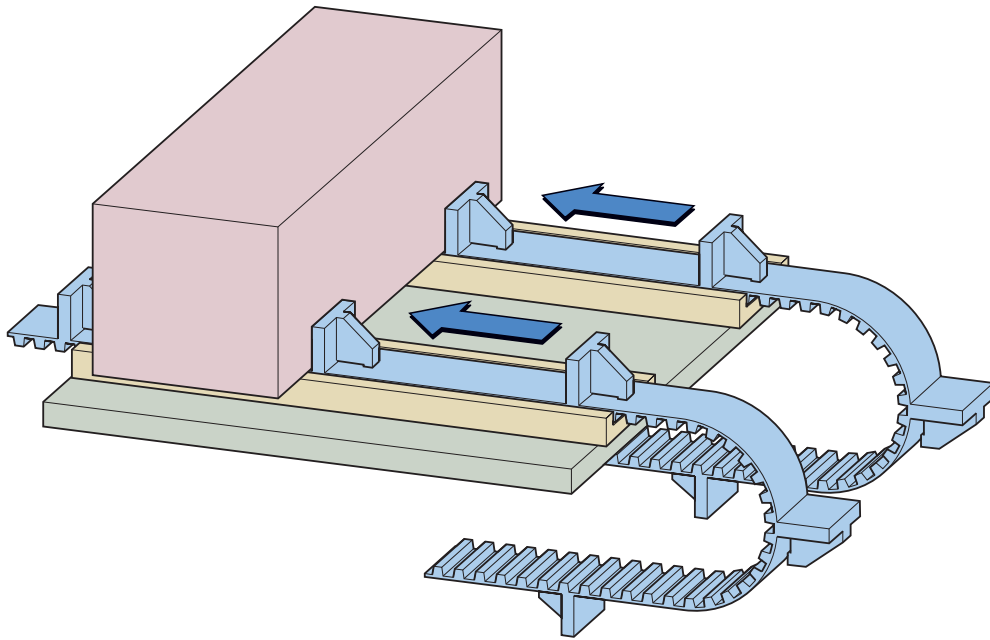

# Profile belt design instructions

## Mold width and number of pulley teeth

Please ensure that any profile to the rear of the belt teeth (Figure A) utilizes multiples of the belt pitch. If there is no other choice, however, the profile can be included in the back of the bottom of the teeth (Figure B). Thick objects (Figure C) being included in the rear of the bottom of the teeth in this way can however influence the belt rolling onto the pulleys and result in damage, thus making it necessary that the width of the mold ( $S_1$ ) be decreased (Figure D). Please refer to the below table as the width of the mold can vary depending on the number of pulley teeth.

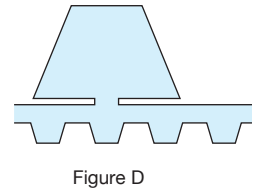
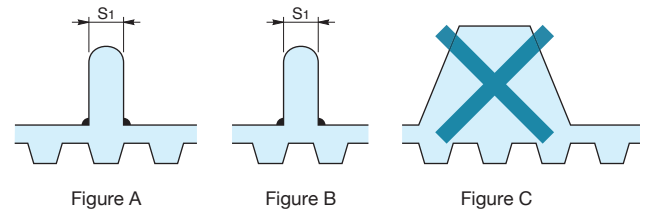

### Maximum dimensions of profile mold width ( $S_1$ ) (mm)

Belt model	Pulley teeth	14	15	16,17	18,19	20~24	25~29	30~39	40~49	50~59	60 or more
		Figure A	Figure B	Figure A	Figure B	Figure A	Figure B	Figure A	Figure B	Figure A	Figure B
MA3	Figure A	—	—	—	—	—	2	3	3	4	4
MA3	Figure B	—	—	—	—	—	—	—	—	—	—
MA5	Figure A	—	2	2	3	3	4	4	5	6	7
MA5	Figure B	—	—	—	—	—	—	—	2	4	5
MA8	Figure A	—	—	—	—	4	5	6	7	9	10
MA8	Figure B	—	—	—	—	—	—	2	2	4	6
AT5	Figure A	—	2	2	3	3	4	4	5	6	7
AT5	Figure B	—	—	—	—	—	—	—	2	4	5
AT10	Figure A	—	4	4	5	5	6	7	9	10	11
AT10	Figure B	—	—	—	—	—	2	2	4	6	9
AT20	Figure A	—	—	—	8	9	9	11	13	15	17
AT20	Figure B	—	—	—	2	3	3	4	6	9	15
T5	Figure A	2	2	2	3	3	4	4	5	6	7
T5	Figure B	—	—	—	—	—	—	—	2	4	5
T10	Figure A	4	4	4	5	5	6	7	9	10	11
T10	Figure B	—	—	—	—	—	2	2	4	6	9
T20	Figure A	—	—	—	8	9	9	11	13	15	17
T20	Figure B	—	—	—	2	3	3	4	6	9	15
XL	Figure A	2	2	2	3	3	4	4	5	6	7
XL	Figure B	—	—	—	—	—	—	—	2	4	5
L	Figure A	3	3	3	4	4	4	5	7	9	9
L	Figure B	—	—	—	—	—	—	2	3	4	7
H	Figure A	4	4	4	5	5	6	7	9	10	11
H	Figure B	—	2	2	2	2	3	4	5	7	9
XH	Figure A	—	—	—	5	5	6	7	9	10	11
XH	Figure B	—	—	—	2	2	3	4	5	7	9

[Example]  
When a T10 Iron Rubber belt and 30 tooth pulleys are used according to the table in the left section of this page  
•Just above the teeth  
•Just above the bottom of the teeth (as described in Figure B above)

## Display method

Note that the belt length direction and belt width direction dimensions are needed in any schematic diagram, as shown in the figure in the right section of this page.

Please set the dimension A to be at least 0.5mm.

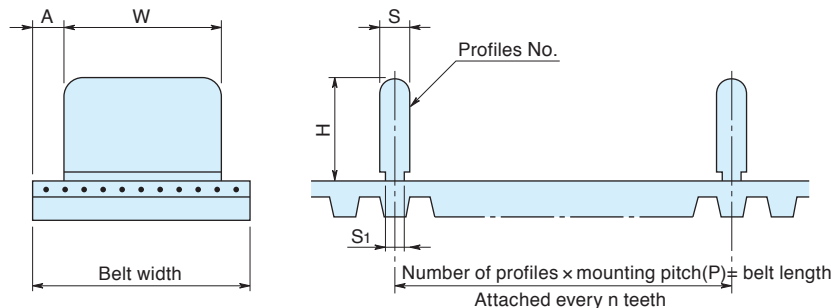

### Profile tolerance before molding

Dimensions S, S <sub>1</sub> , W, H <sub>0</sub>	Tolerance
up to 4	±0.2
Over 4 up to 16	±0.3
Over 16 up to 31	±0.4
Over 31 up to 63	±0.5

### Profile mold tolerance

Dimensions A, H	Tolerance
16	±0.5
Over 16 up to 31	±0.7
Over 31 up to 63	±1.0

Dimensions P	Tolerance	
	MA3, MA5, MA8, AT5, AT10, T5, T10, XL, L, H	AT20, T20, XH
up to 63	±0.4	±0.6
Over 63 up to 125	±0.5	±0.8
Over 125 up to 250	±0.6	±1.0
Over 250 up to 500	±0.9	±1.5

•If the profile is to be included just above the teeth or to the rear just above the bottom of the teeth

## Height of the profile

The dimensions of the profile height will decrease by approximately 0.5mm because of the space needed for the mold, although only if molded with the belt.

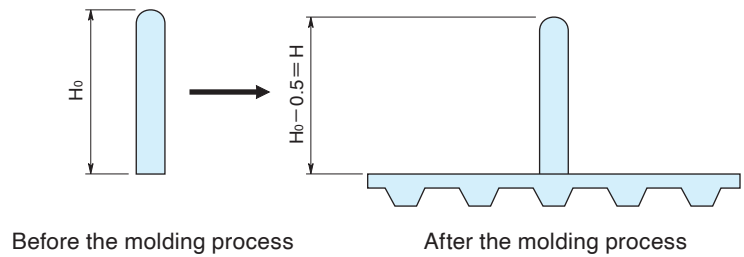

## Additional profile processing

Additional profiles to those provided in the Profile dimensions table are supported but ensure to contact us and specify the details (please include a schematic illustration). Ensure to contact us as the supported dimensions are limited.

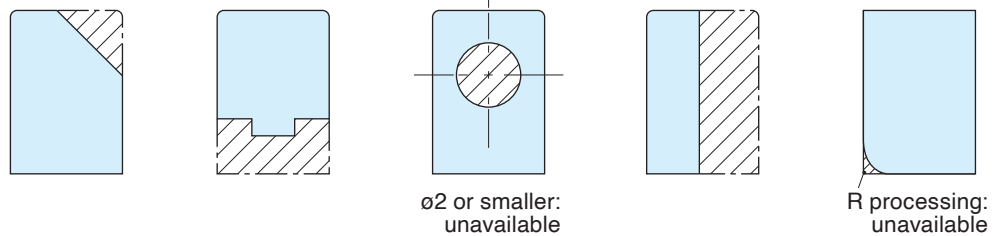

## Special profile molds

With any special shape profiles attention should be paid to the mold section and profile shape in maintaining the tracking between the pulleys and the belt.

In the case provided in Figure E the flexibility of the belt can be ensured by molding the center part only and spacing the left and right sides apart. In the case provided in Figure F the flexibility can be ensured by molding the left side only and spacing the right side apart.

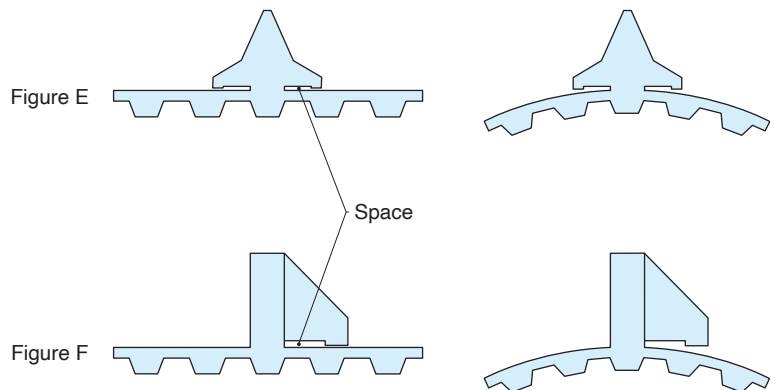

## Burring of molded parts

Burring of the molded parts can occur from the molding process.

If any burring could affect functionality then they will need to be removed. In this case please specify "No remaining burrs" on the schematic illustration you provide.

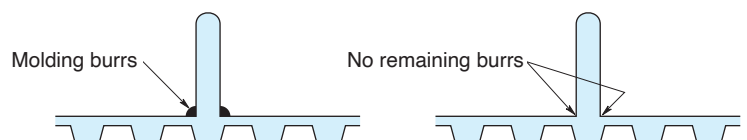

[Note]

That any burrs within the space shown in Figure E and Figure F cannot be removed.

- Repair and remolding of profiles not supported.
- Please ensure compatibility before use when mounting any other attachments onto a profile, or in the case that vibrations or sudden load will affect the profile due to intermittent feeds and other procedures.
- Please contact us regarding the molding of any profiles onto belts of a width of 150mm or over.

# Profile dimensions table

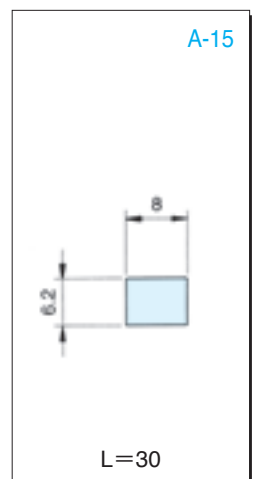
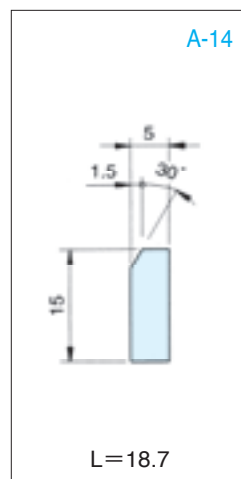
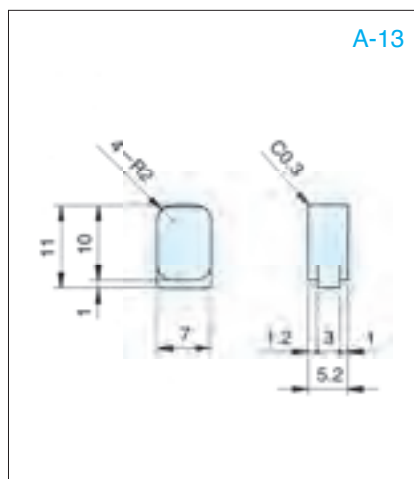
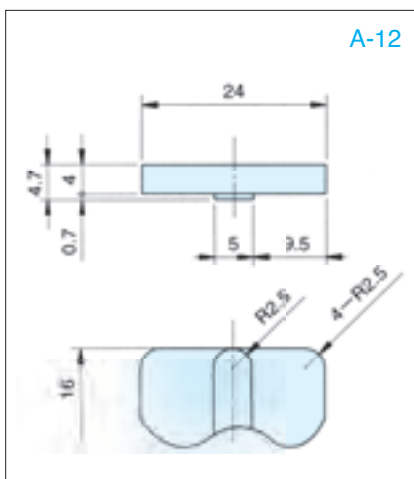
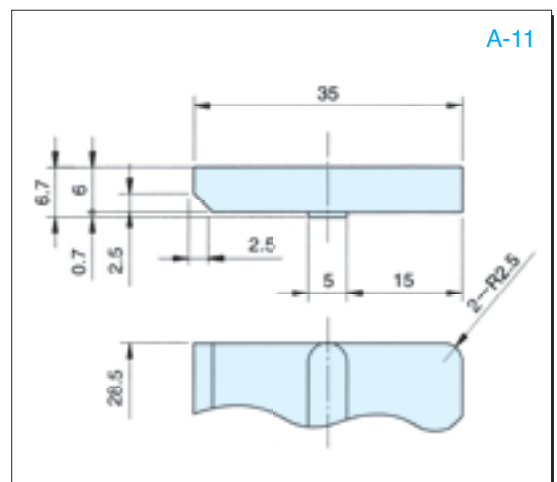
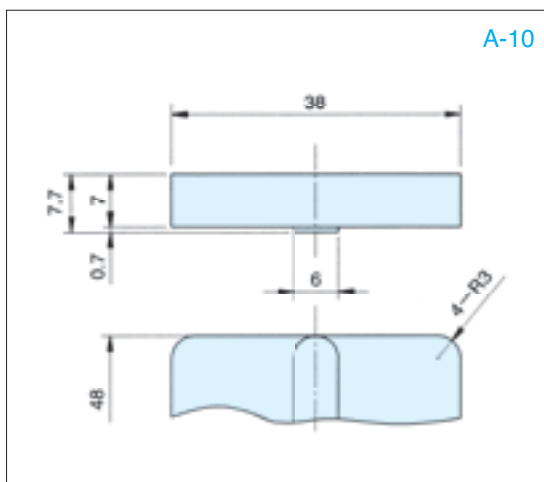
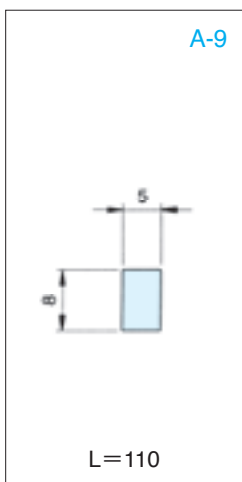
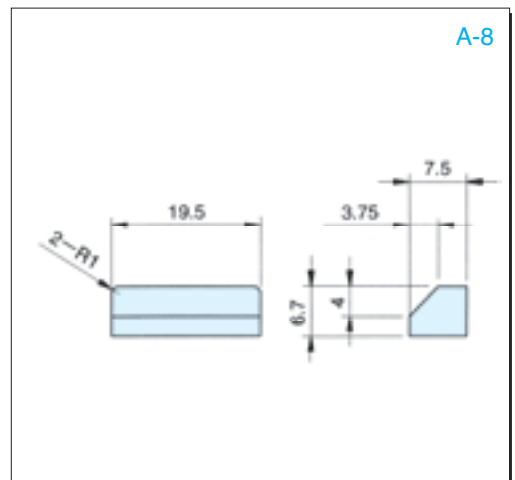
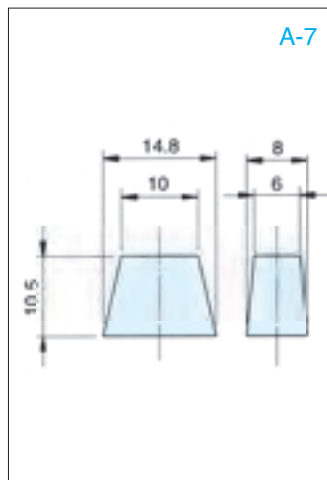
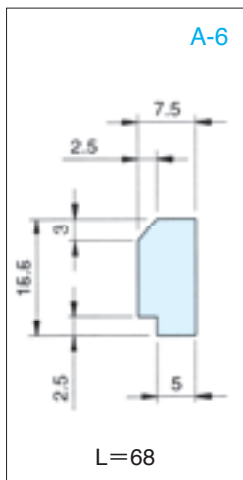
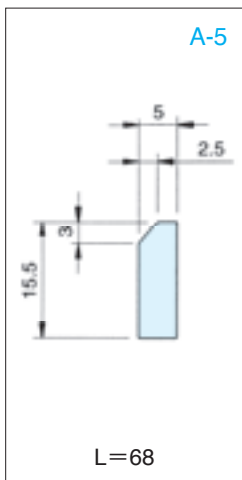
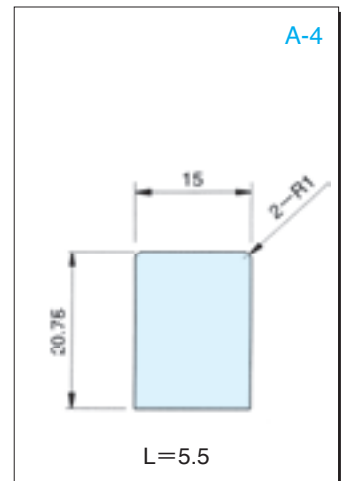
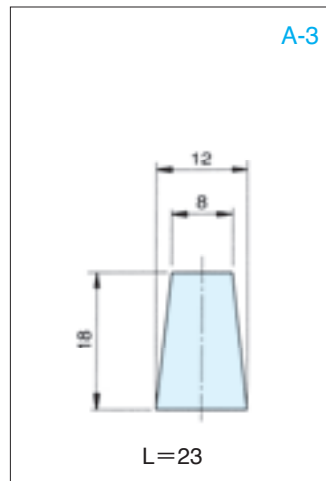
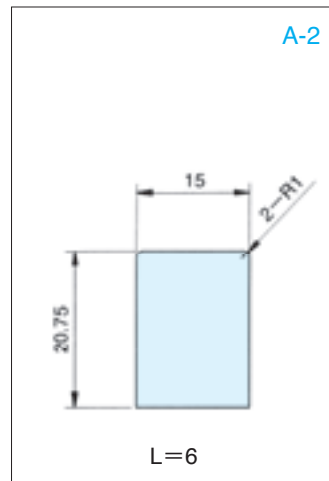
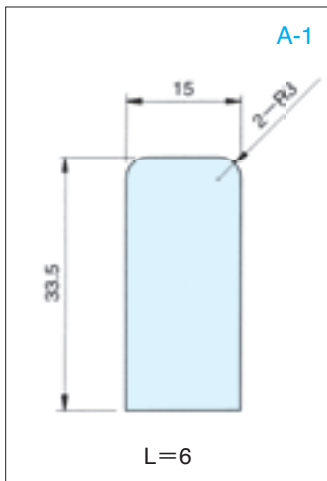

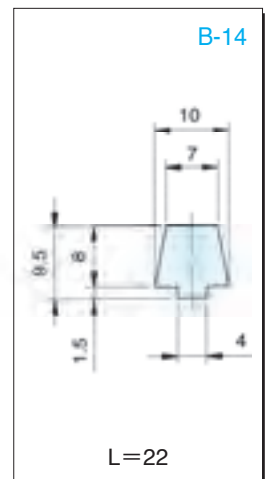
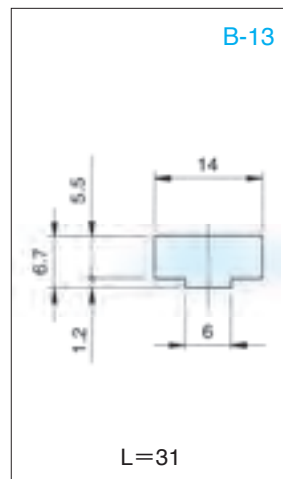
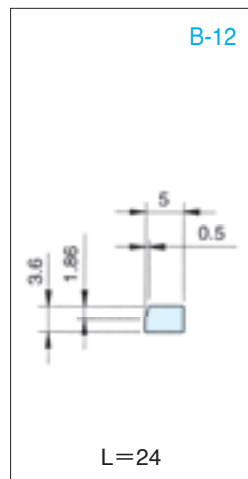
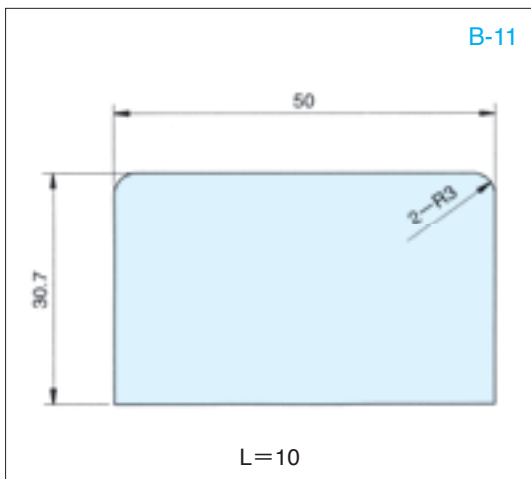
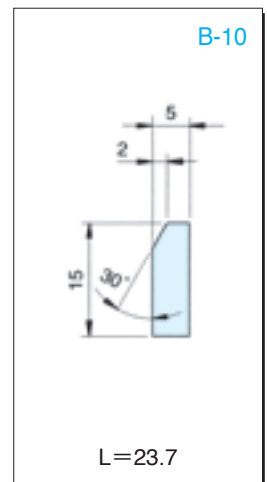
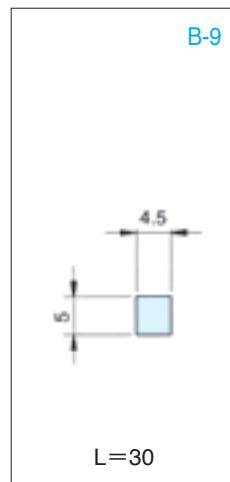
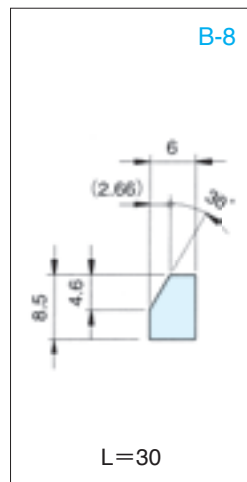
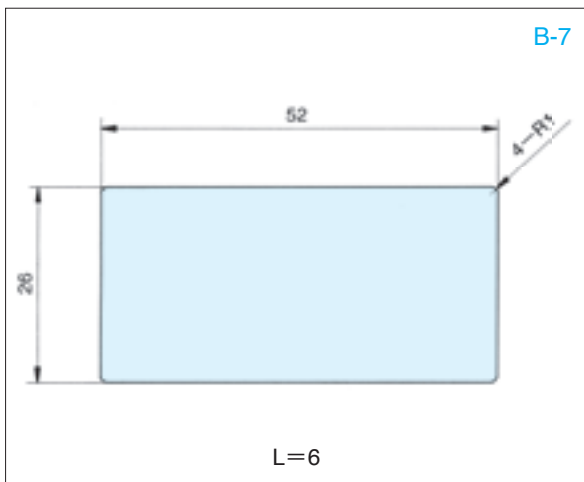
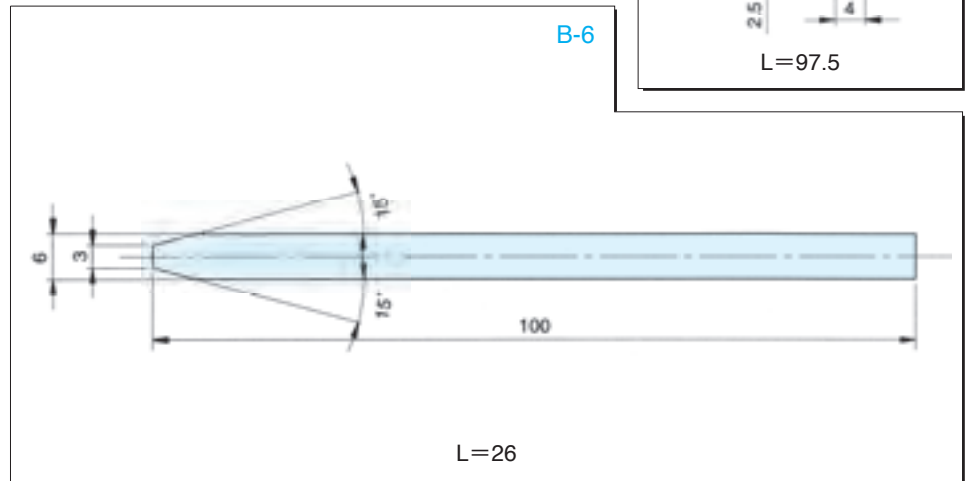
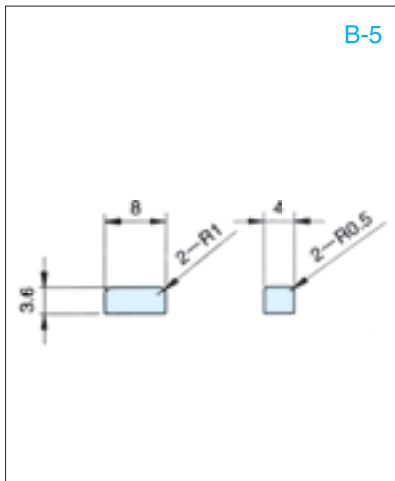
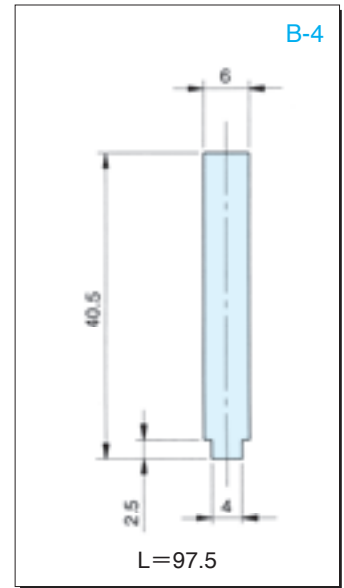
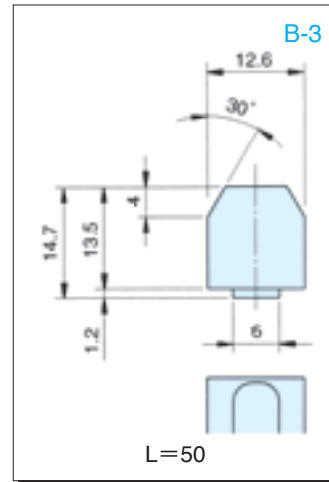
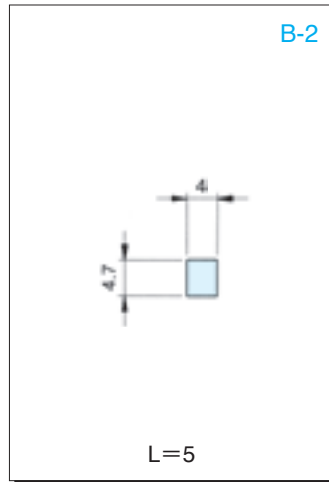
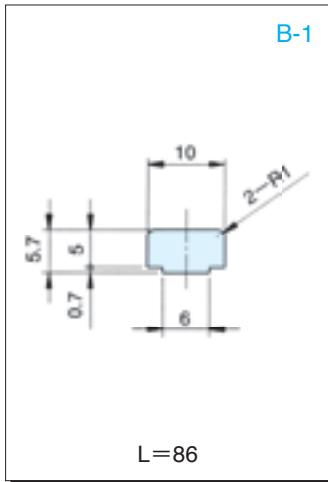

# Profile dimensions table

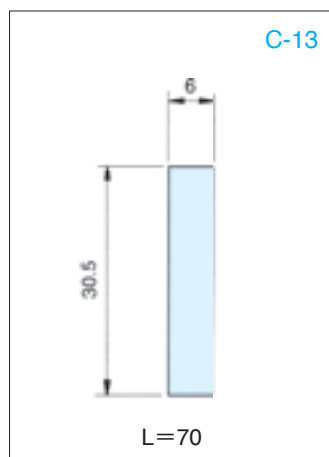
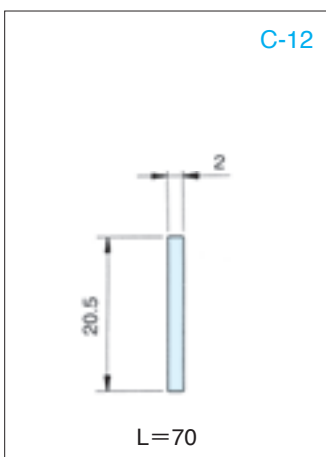
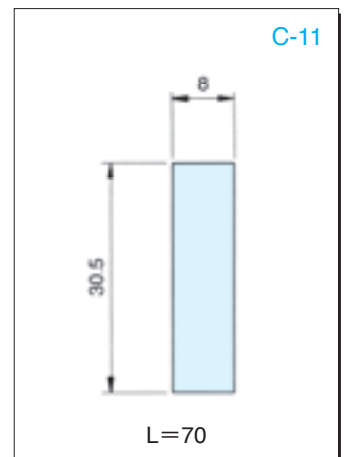
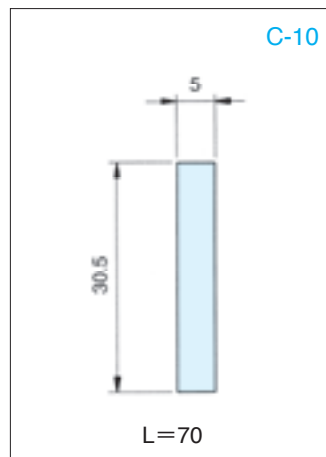
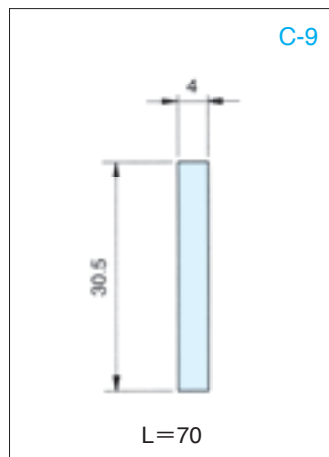
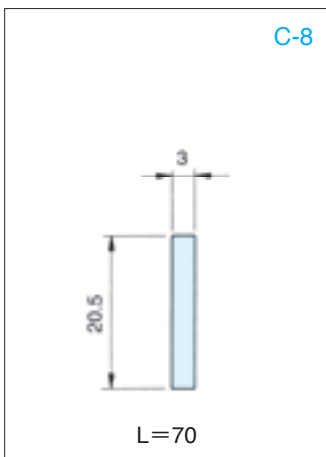
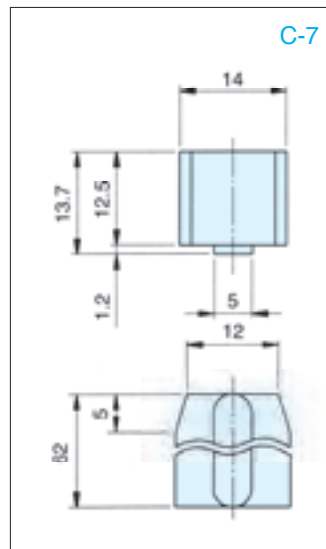
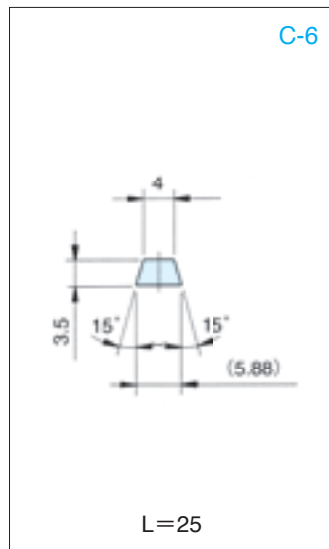
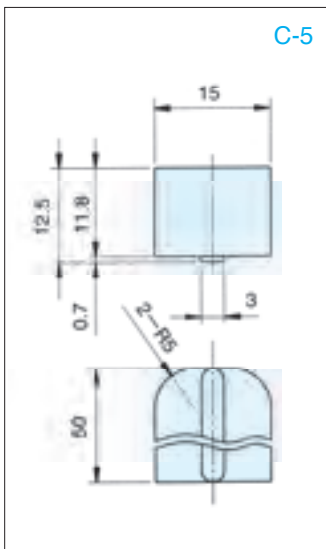
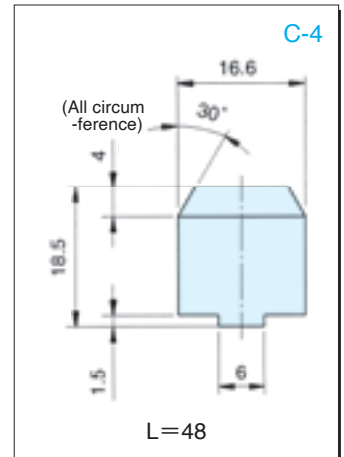
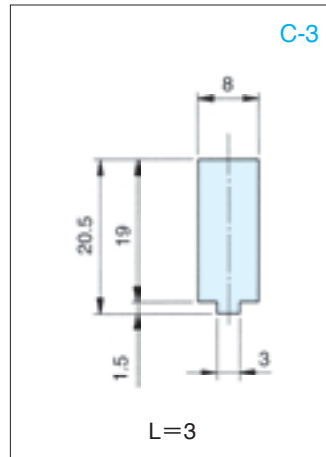
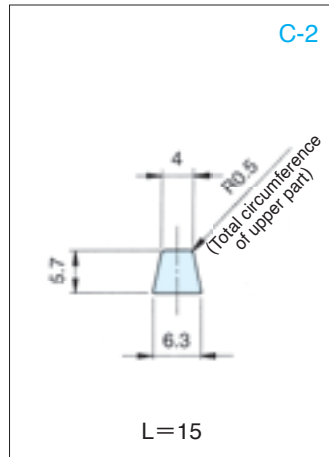
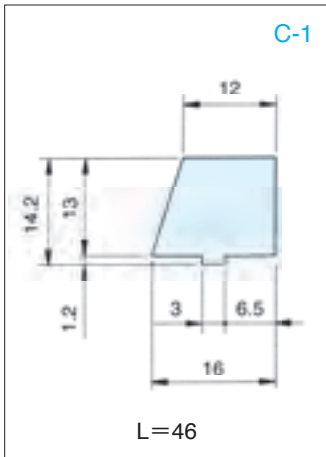



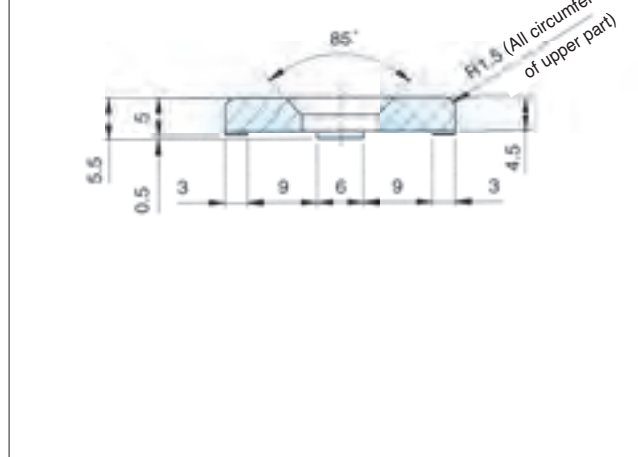
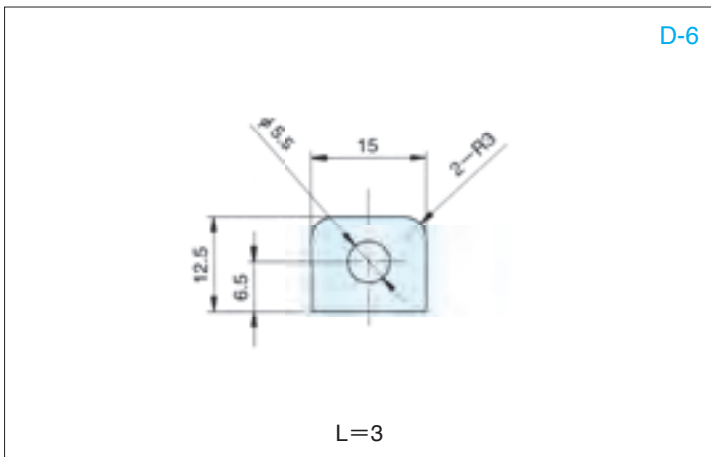
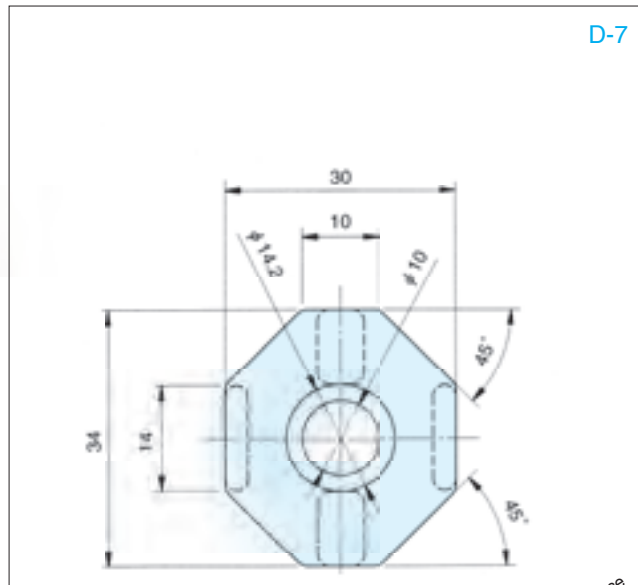
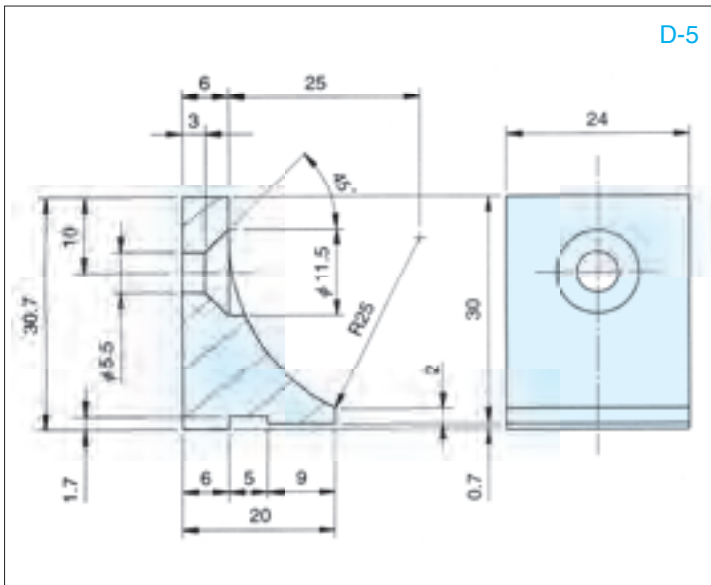
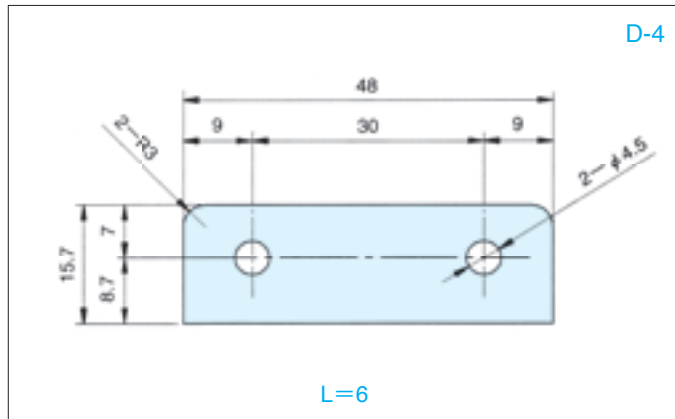
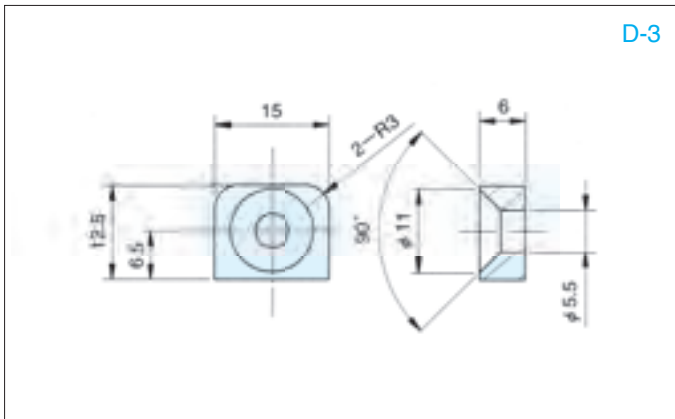
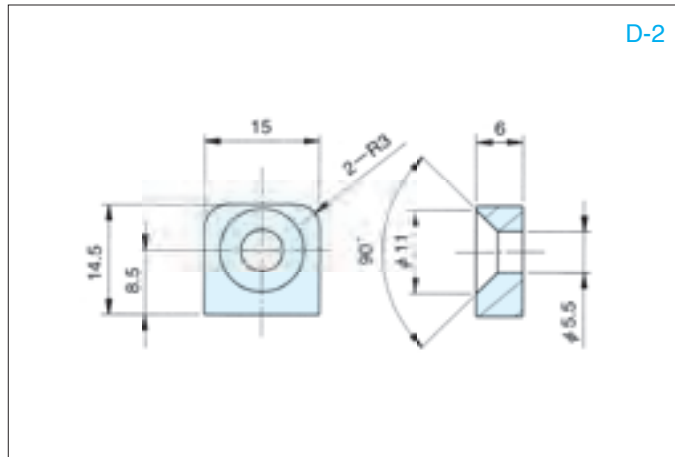
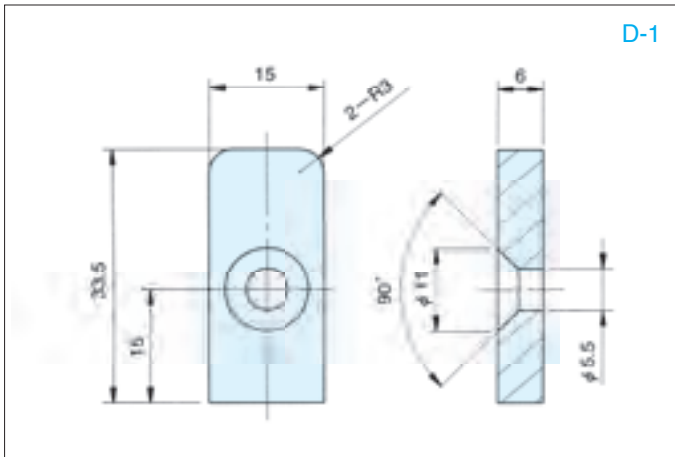

# Profile dimensions table

<p>E-1</p> <p>L=17.5</p>	<p>E-2</p> <p>L=23</p>	<p>E-3</p> <p>L=24</p>	<p>E-4</p> <p>L=38</p>	<p>E-5</p> <p>L=68</p>
<p>E-6</p> <p>L=62</p>	<p>E-7</p> <p>L=99</p>	<p>E-8</p>	<p>E-9</p> <p>L=38</p>	
<p>E-10</p>	<p>E-11</p>	<p>E-12</p> <p>L=34</p>		
<p>E-13</p>	<p>E-14</p> <p>L=50</p>	<p>E-15</p> <p>L=3.5</p>	<p>E-16</p> <p>L=12.7</p>	
<p>E-17</p> <p>(Total crest on both sides)</p> <p>L=70</p>	<p>E-18</p> <p>L=70</p>	<p>E-19</p> <p>L=70</p>		

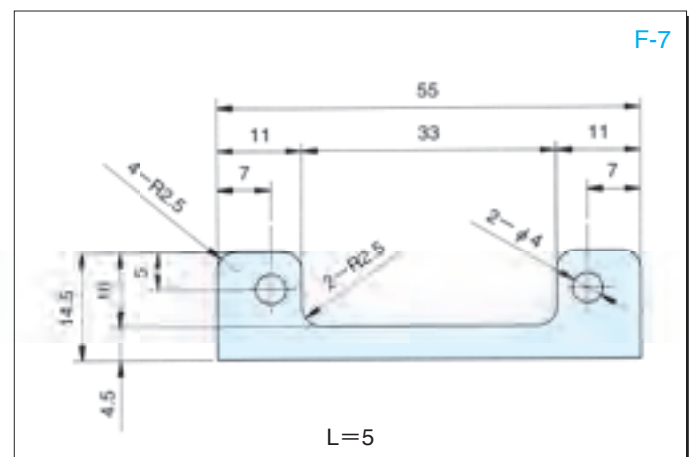
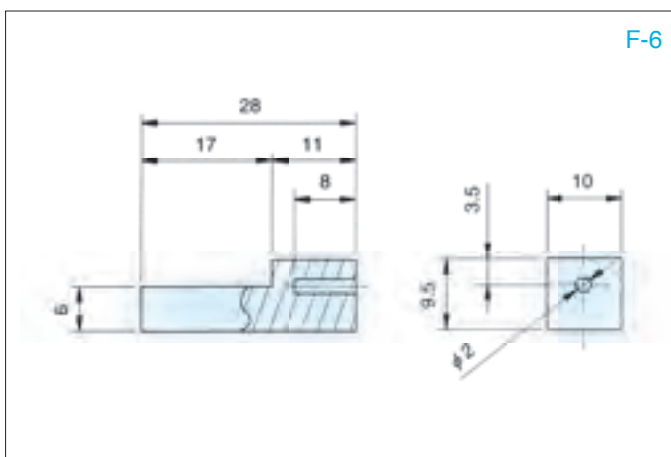
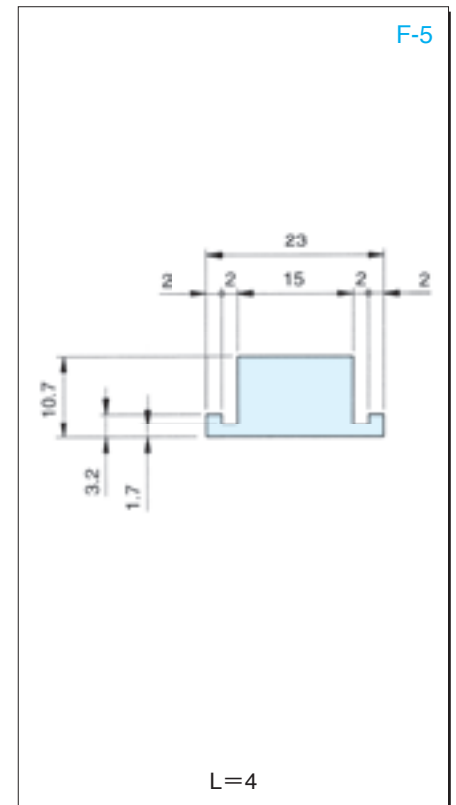
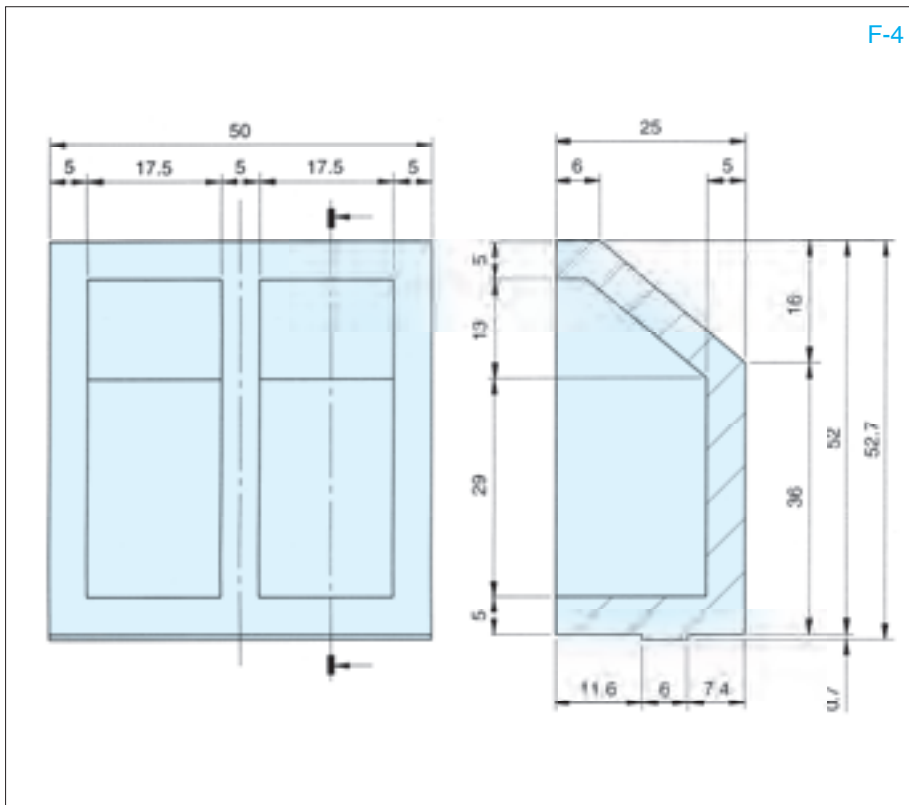
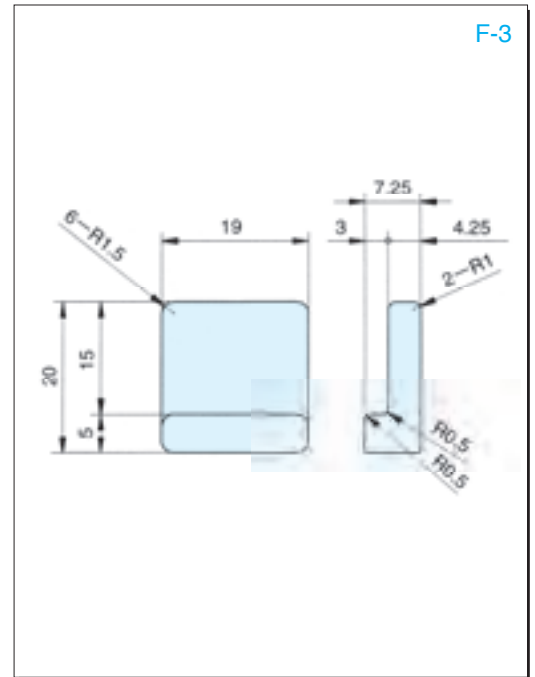
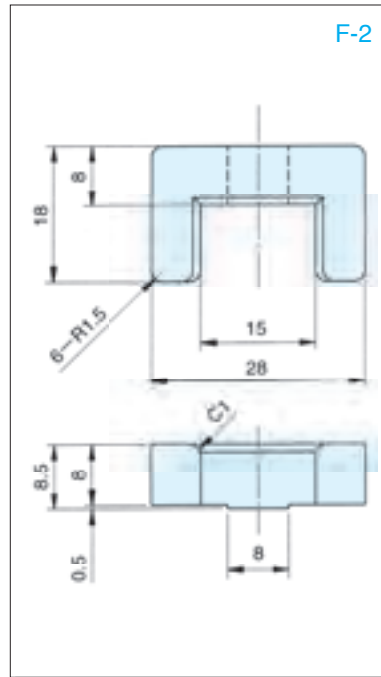
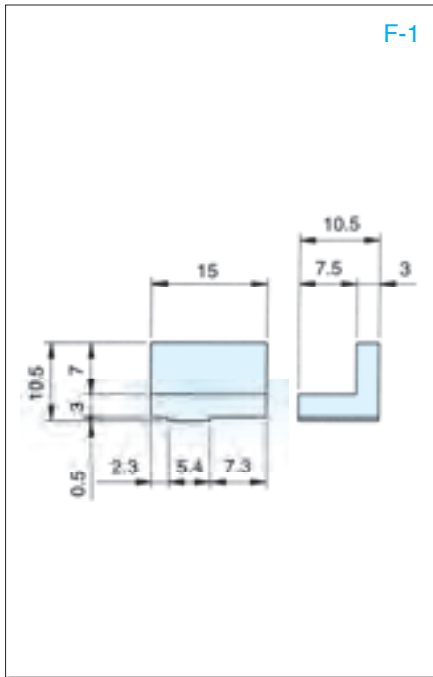

# Profile dimensions table

G-1

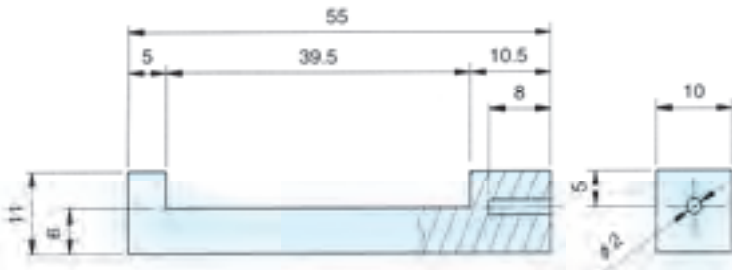

G-2

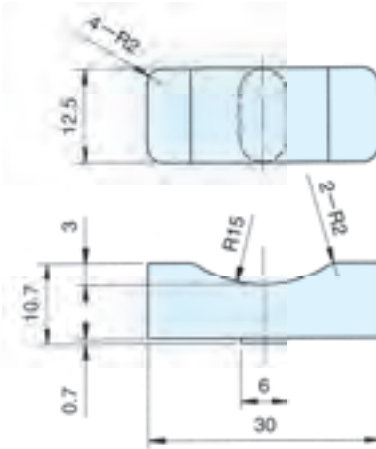

G-3

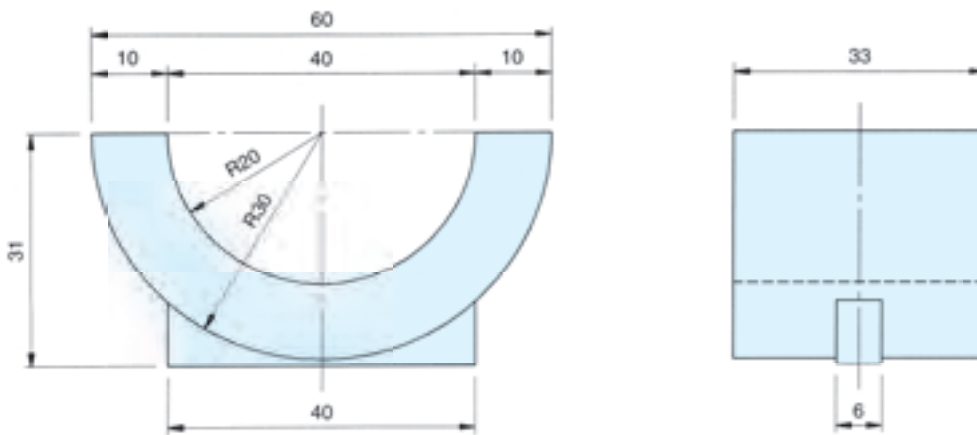

G-4

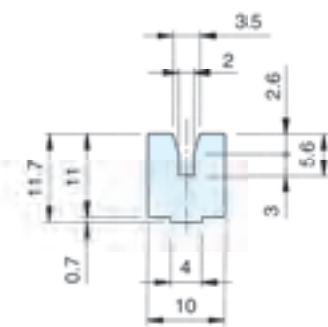

L = 6

G-5

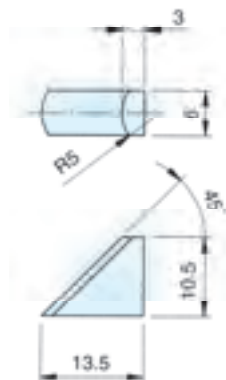

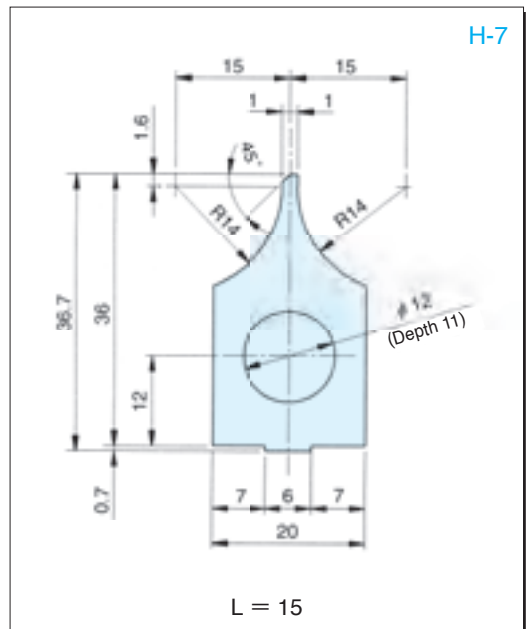
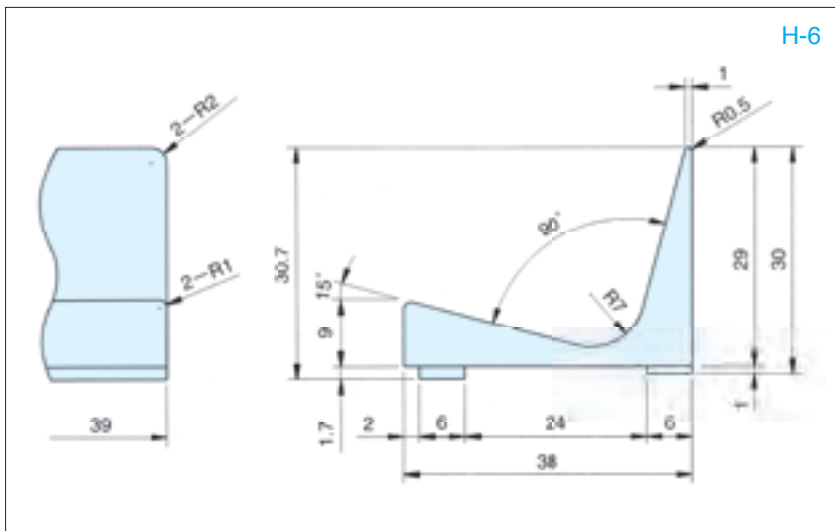
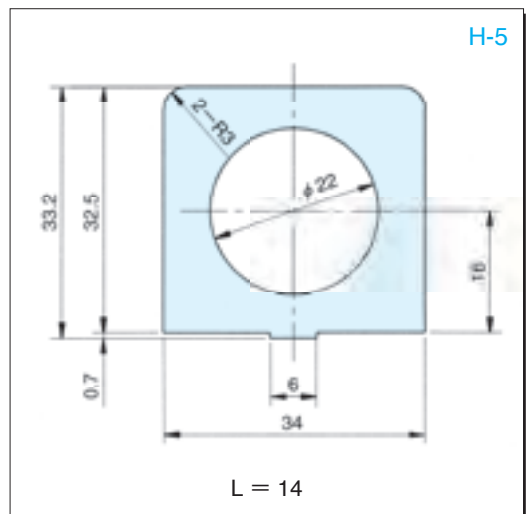
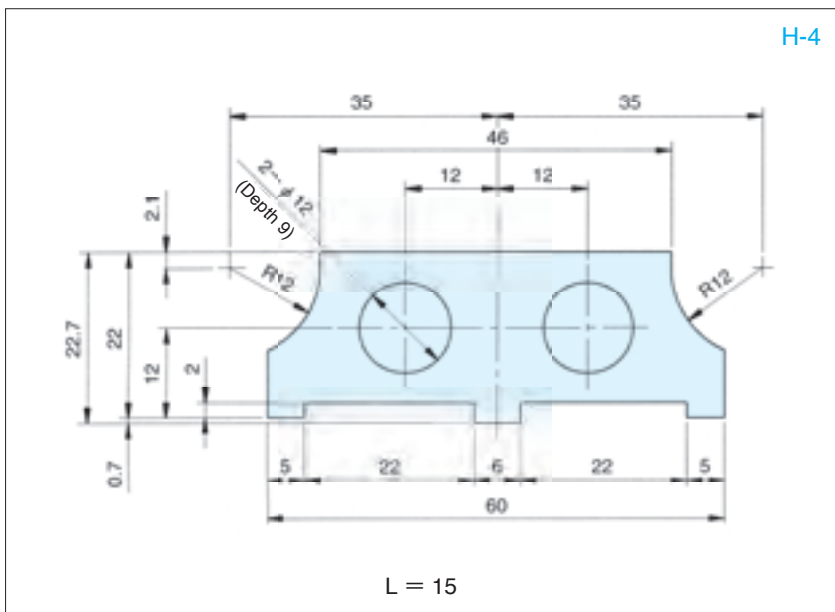
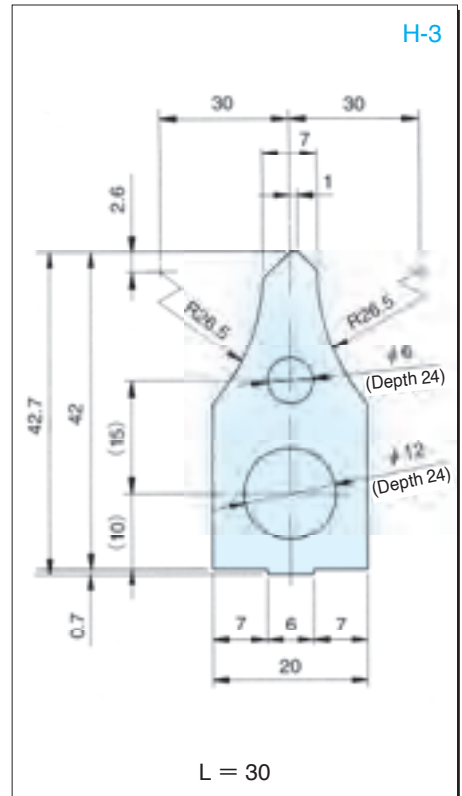
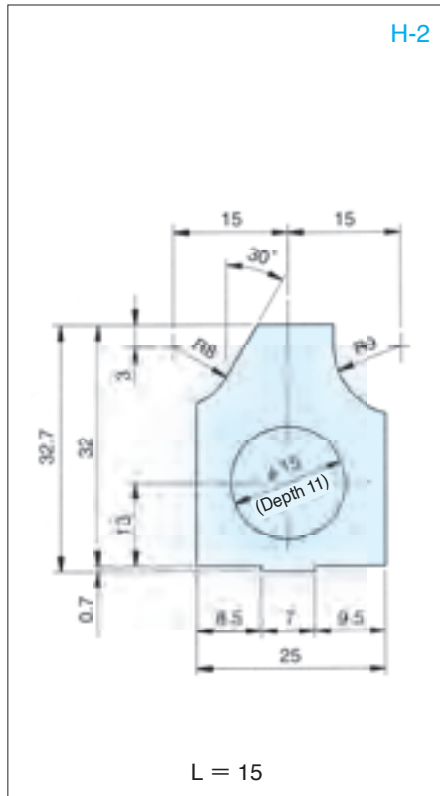
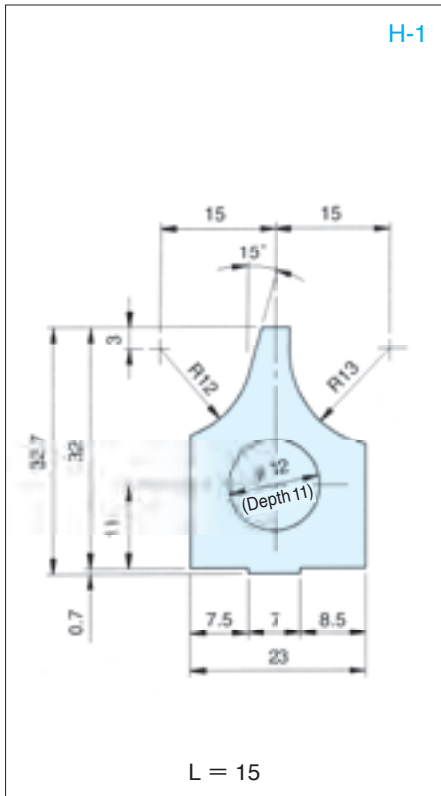



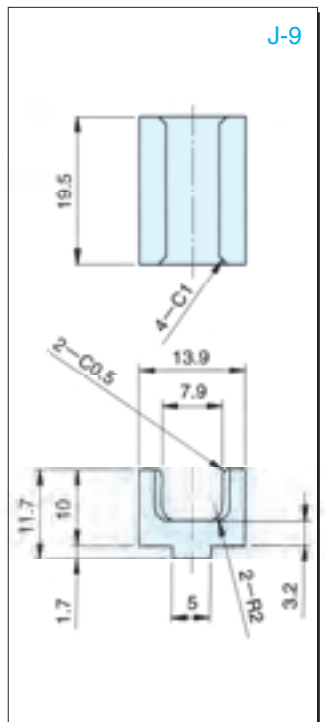
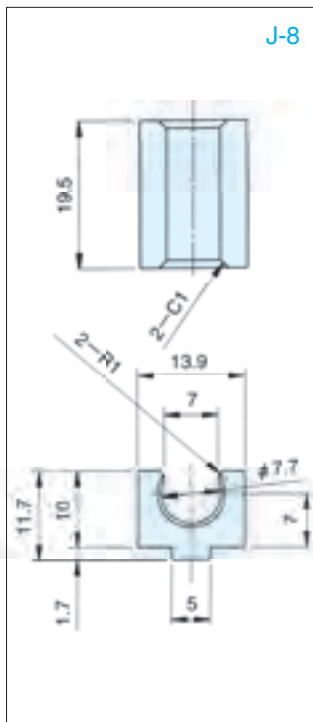
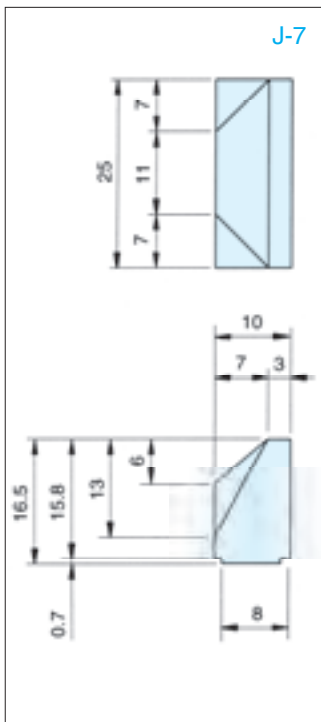
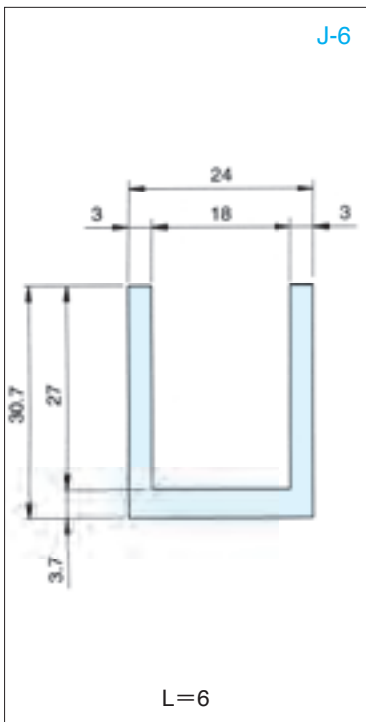
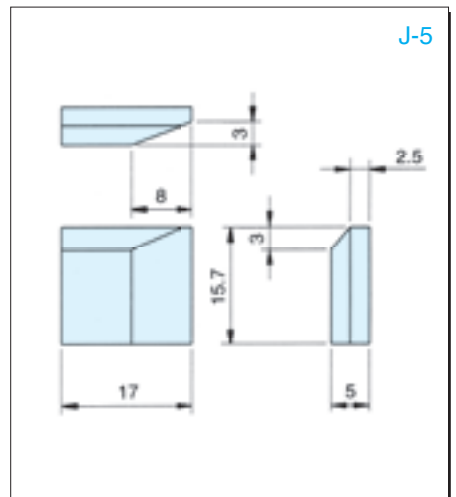
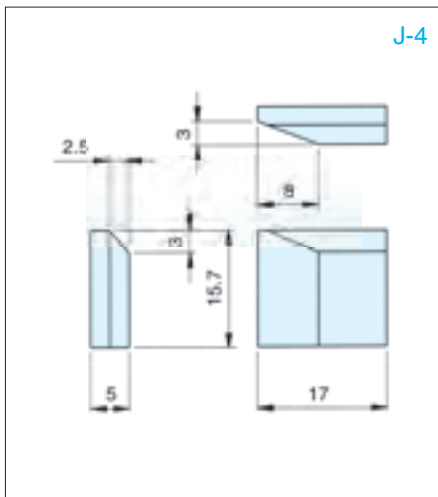
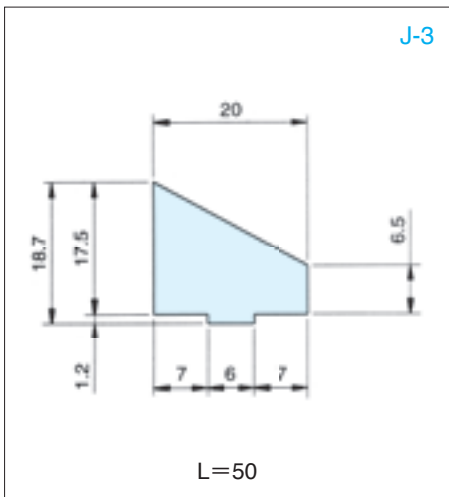
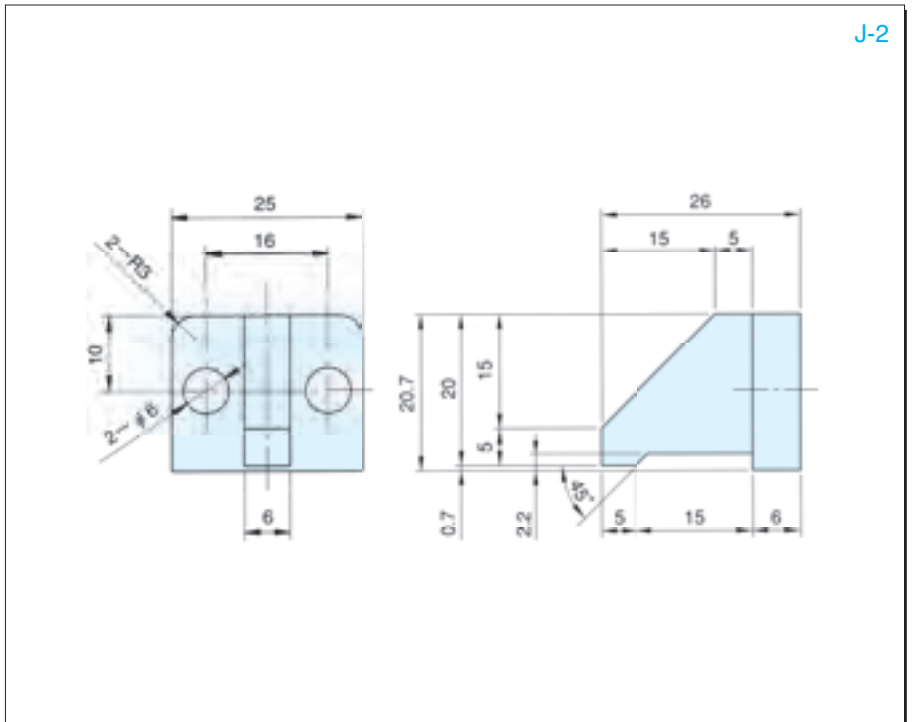
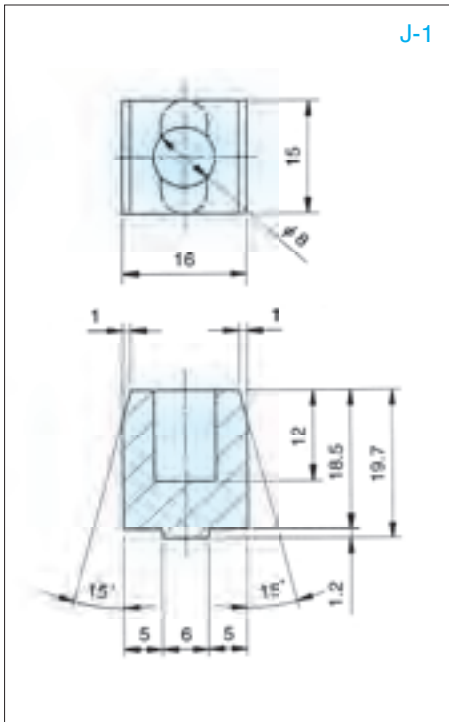

# Profile dimensions table

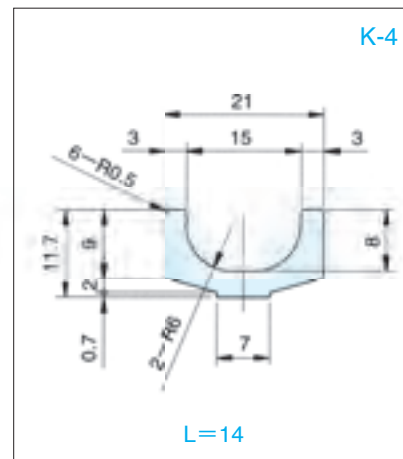
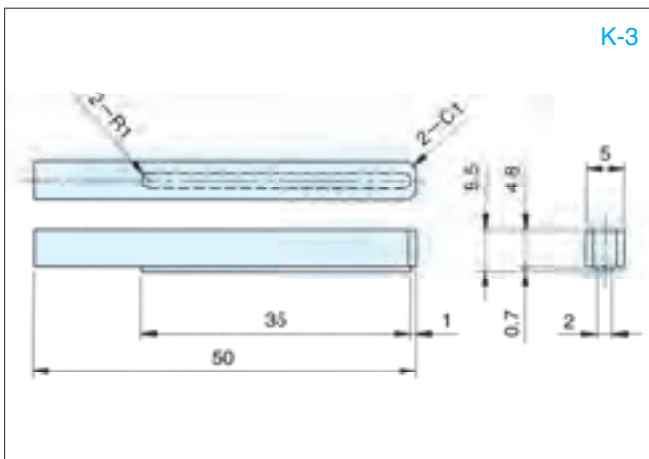
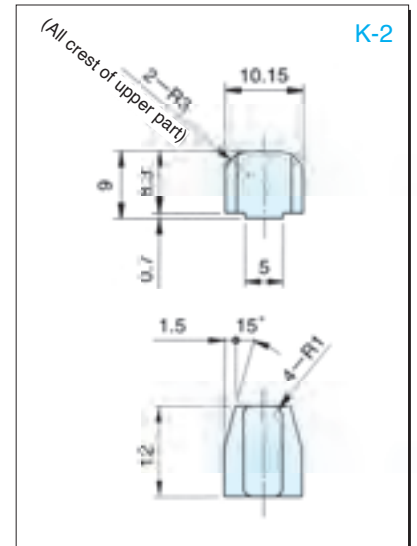
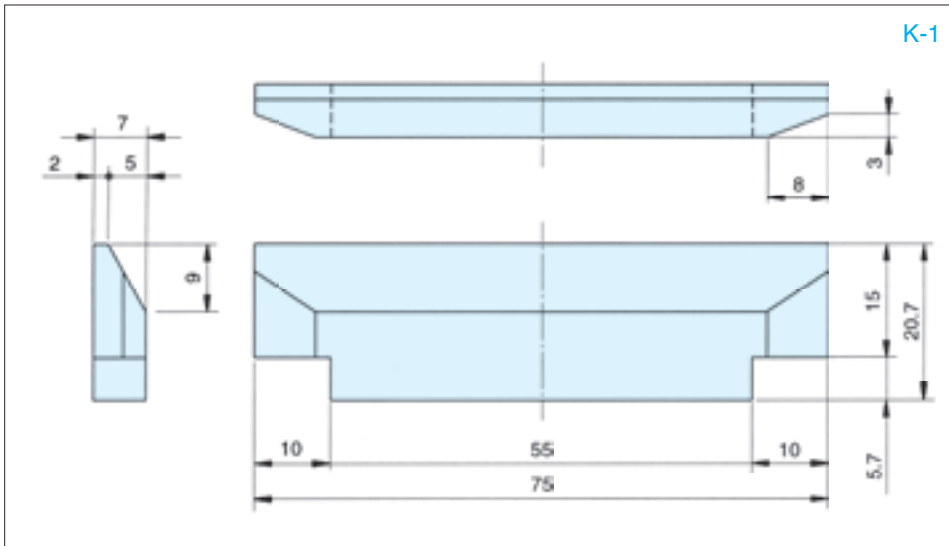

L=14

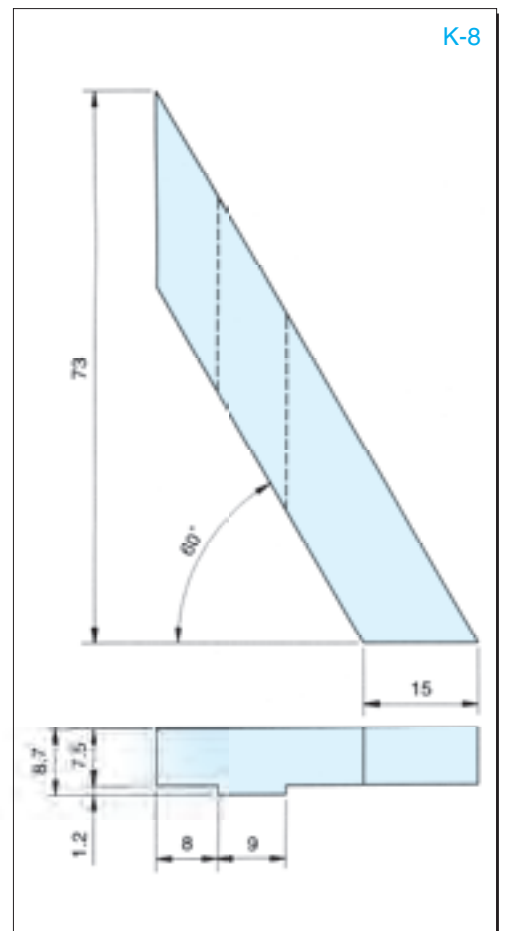
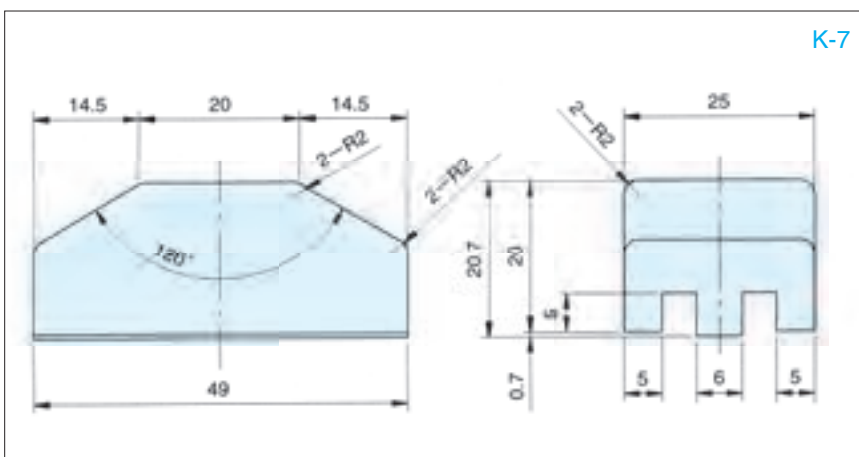
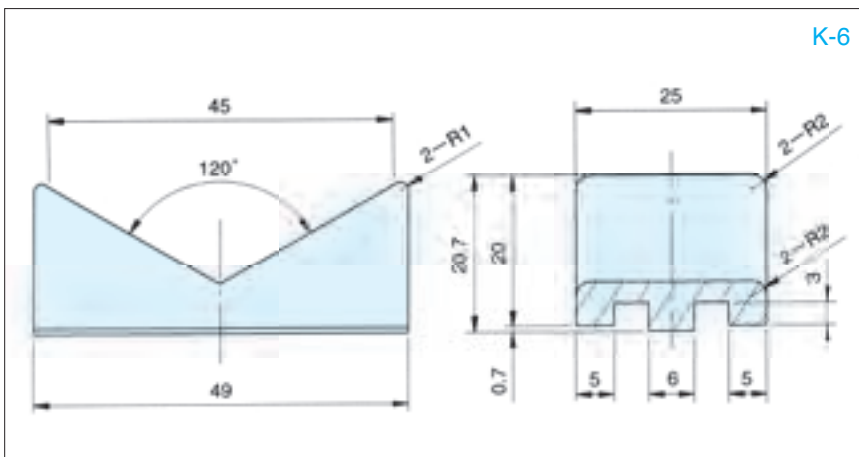
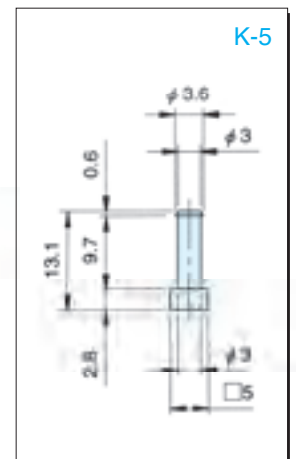



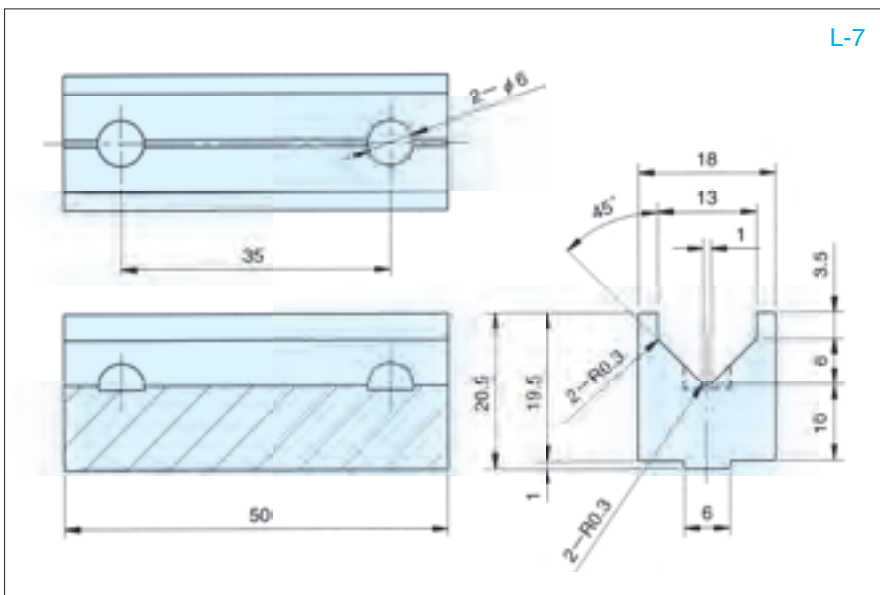
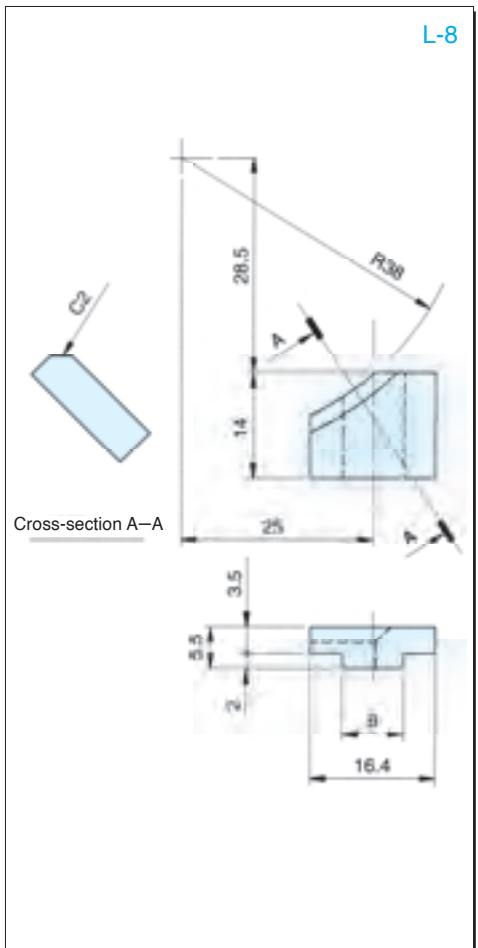
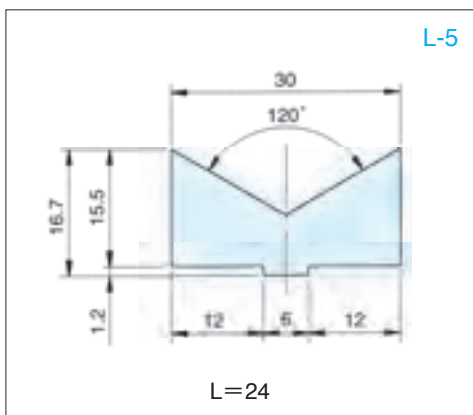
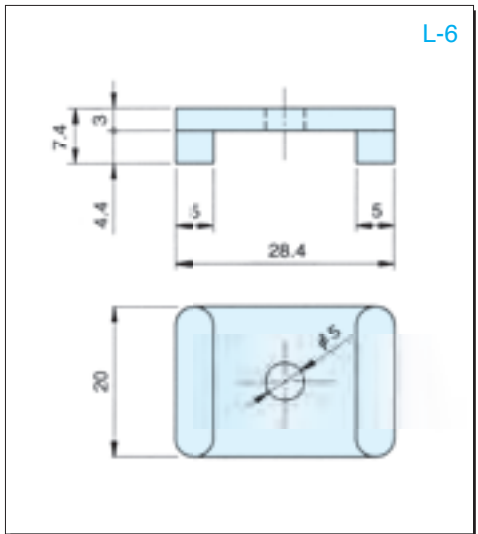
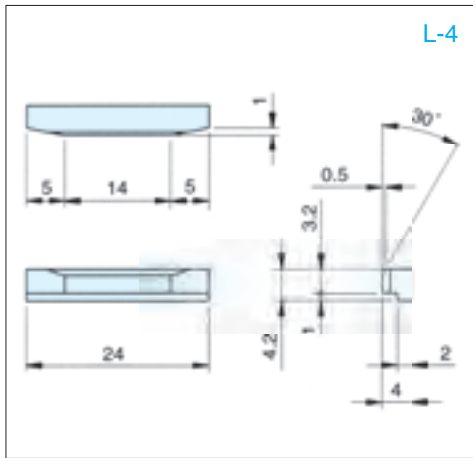
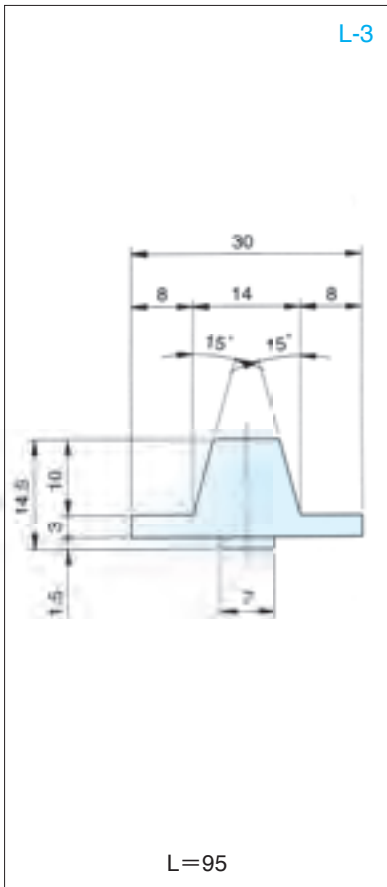
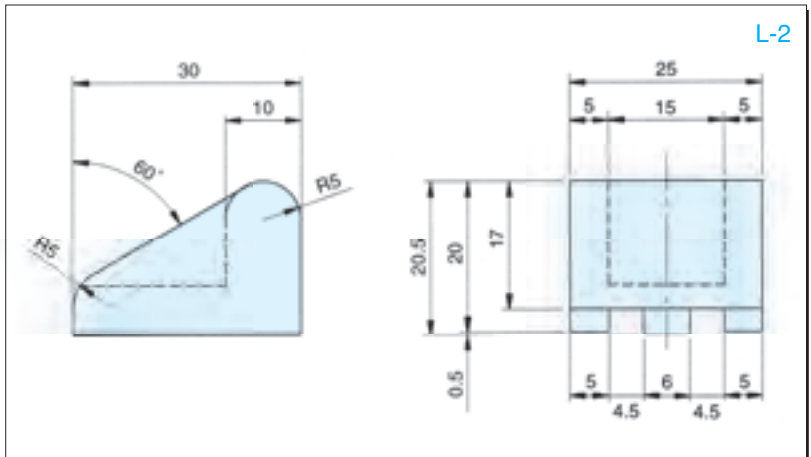
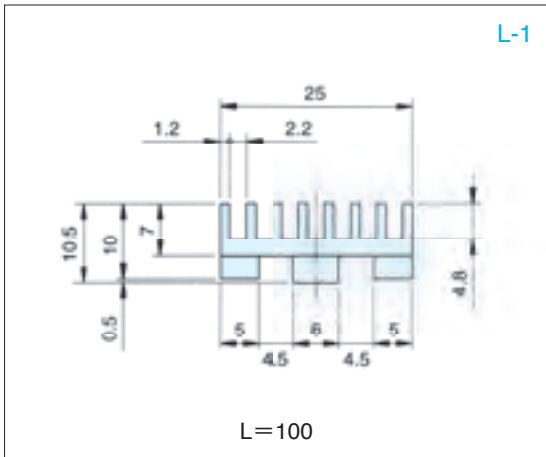

# Profile dimensions table

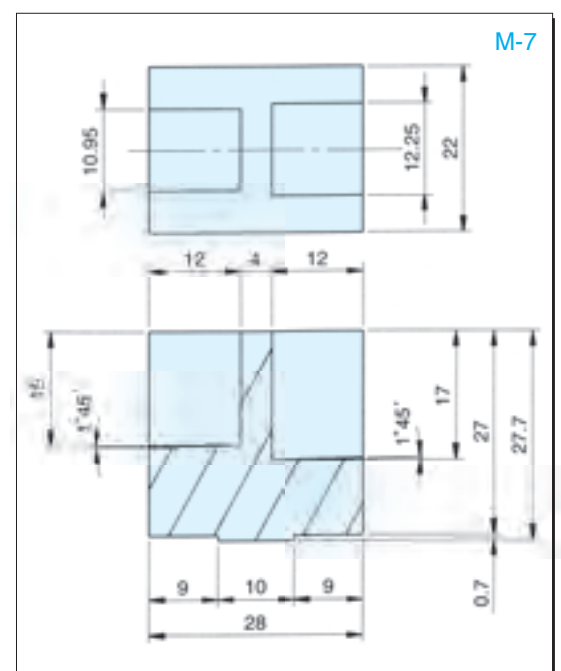
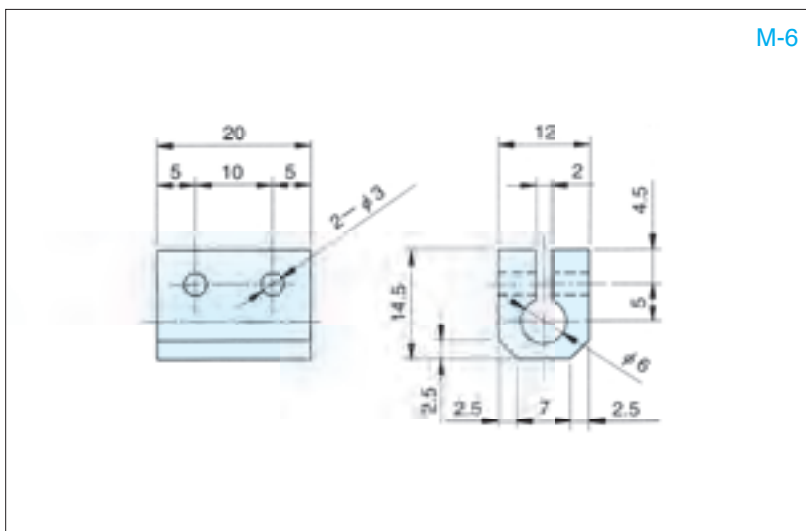
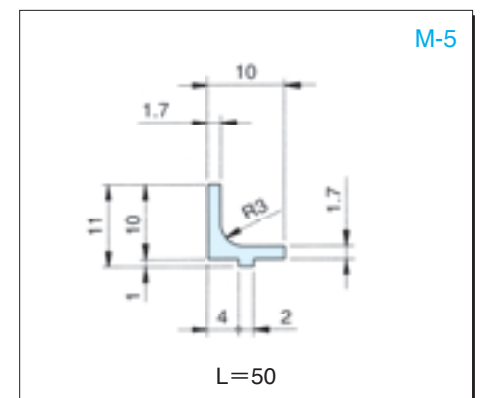
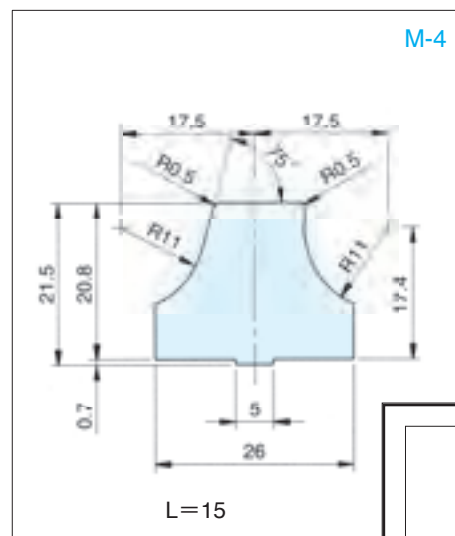
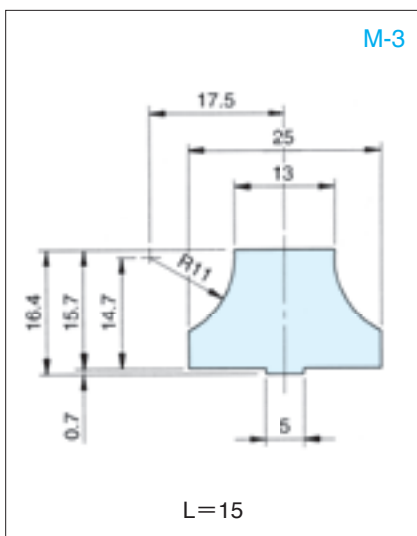
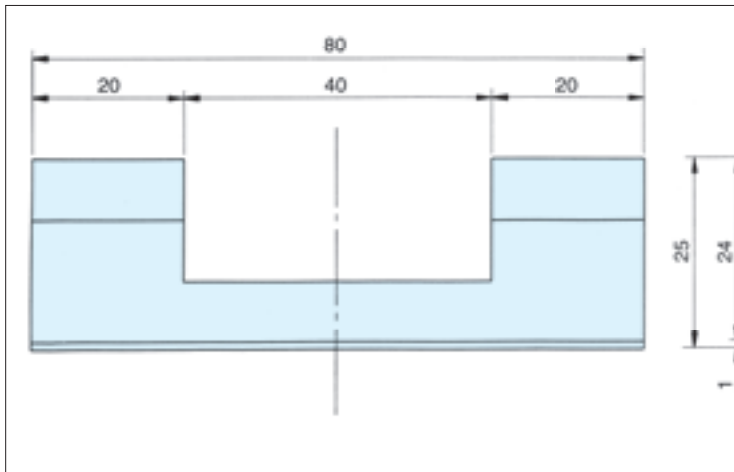
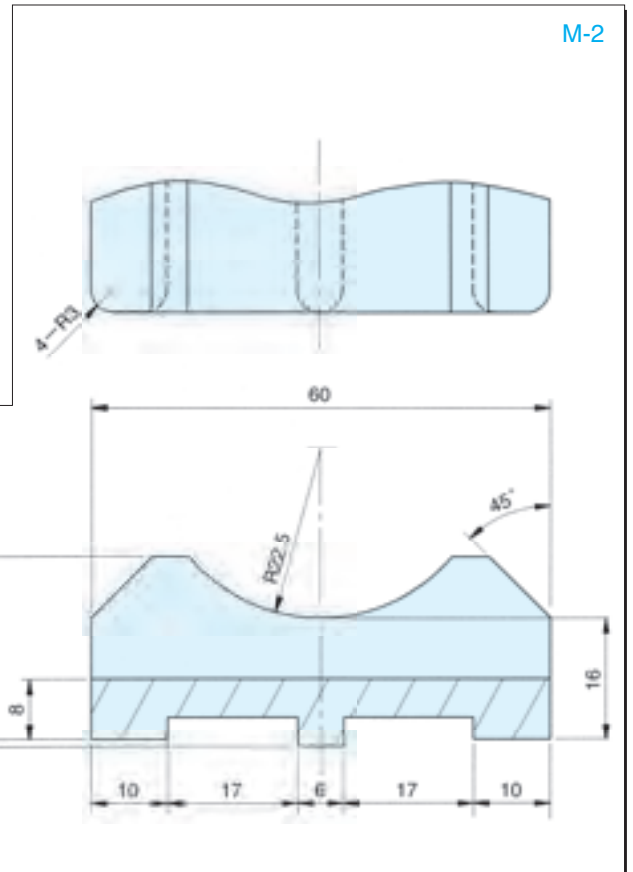
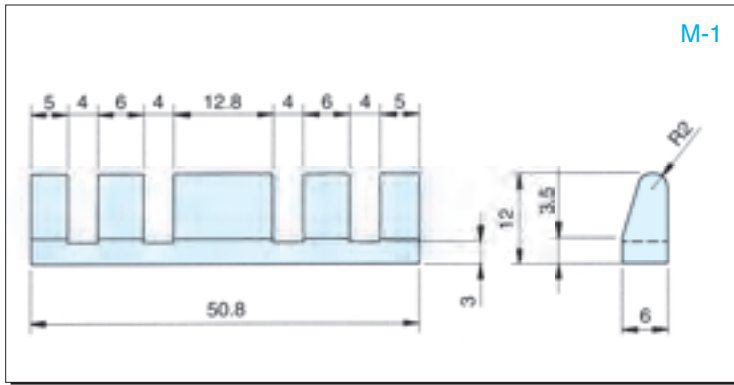

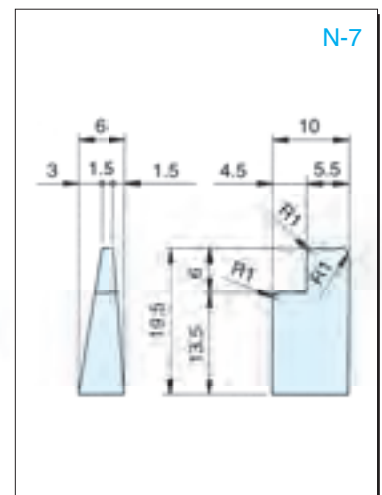
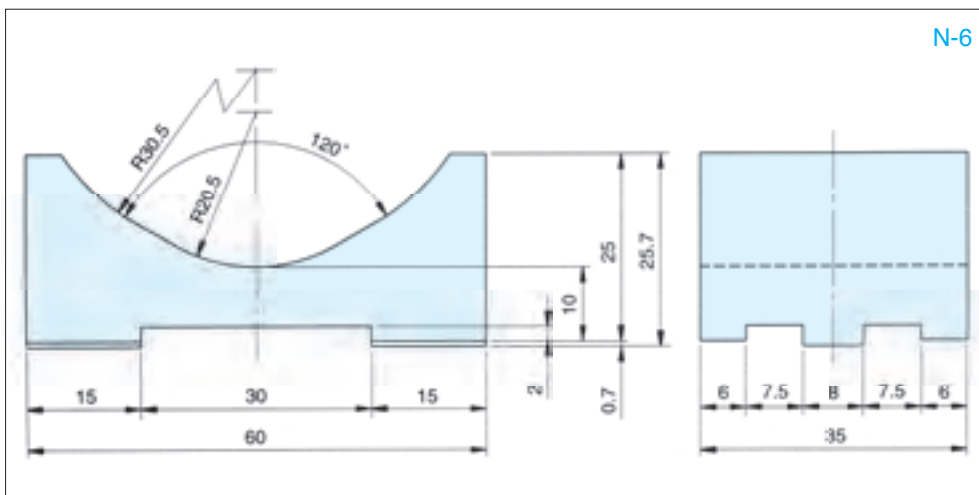
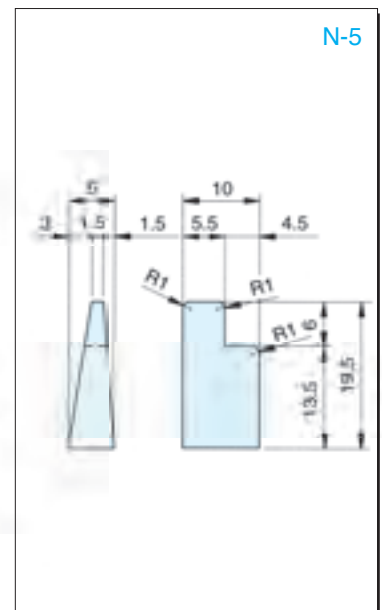
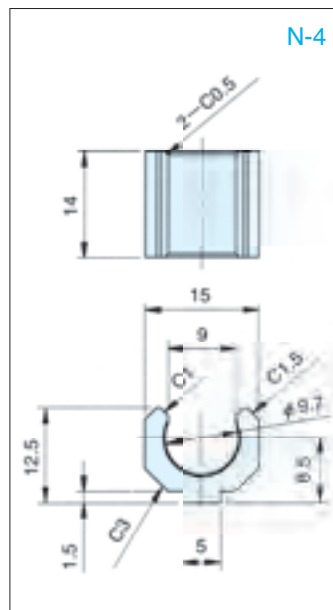
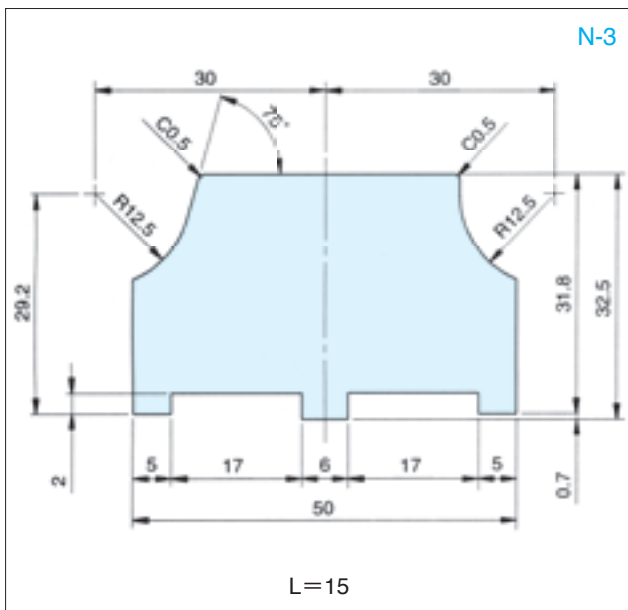
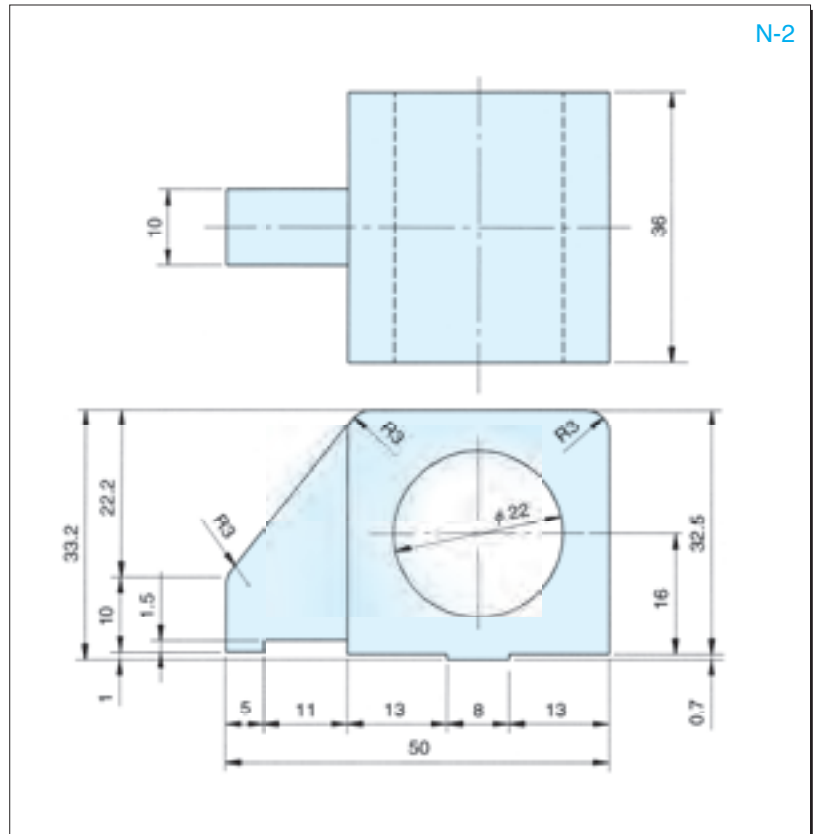
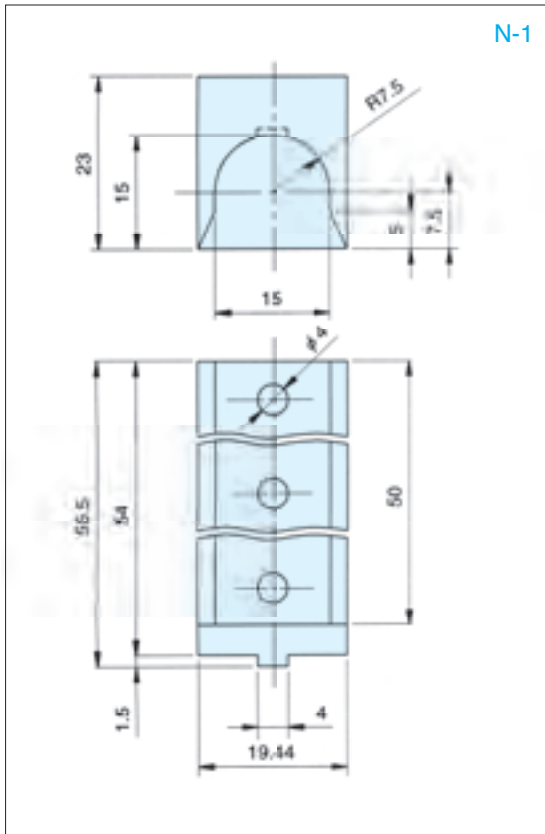

# Profile dimensions table

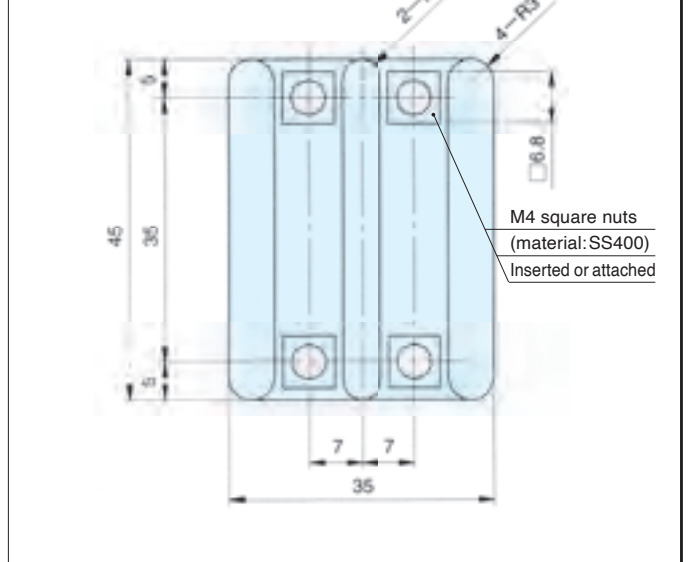
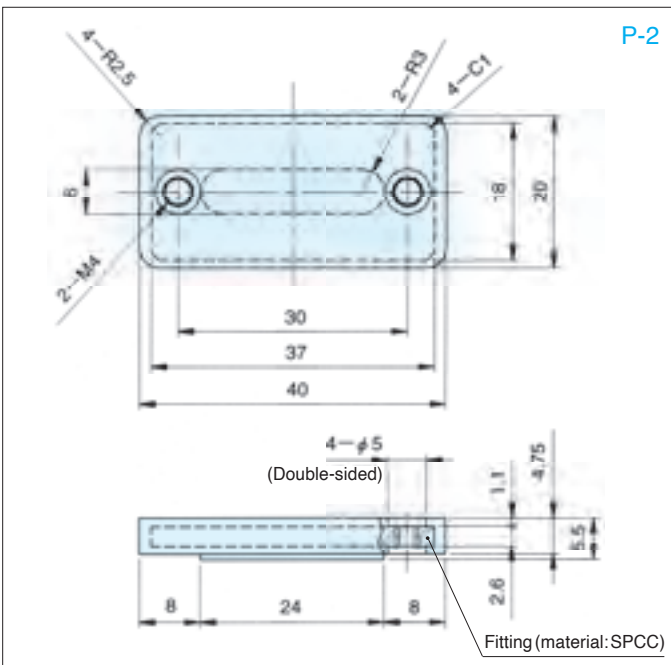
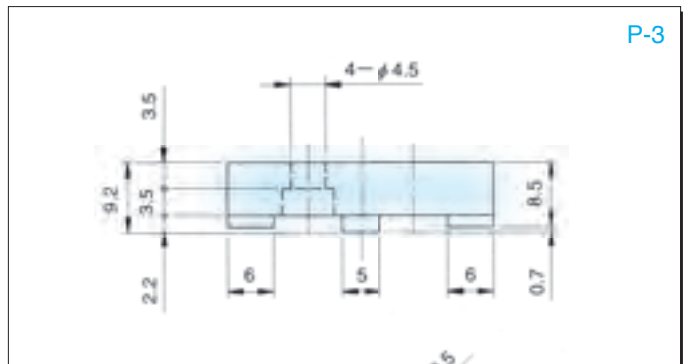
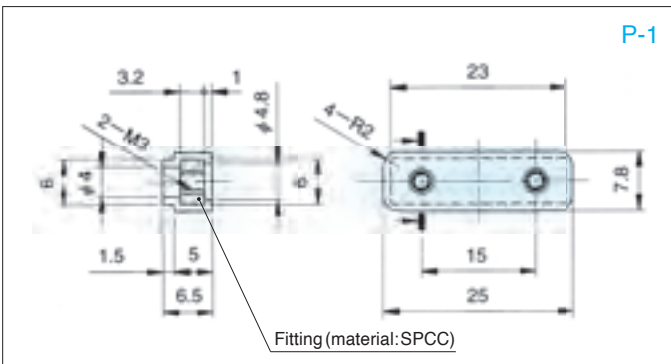
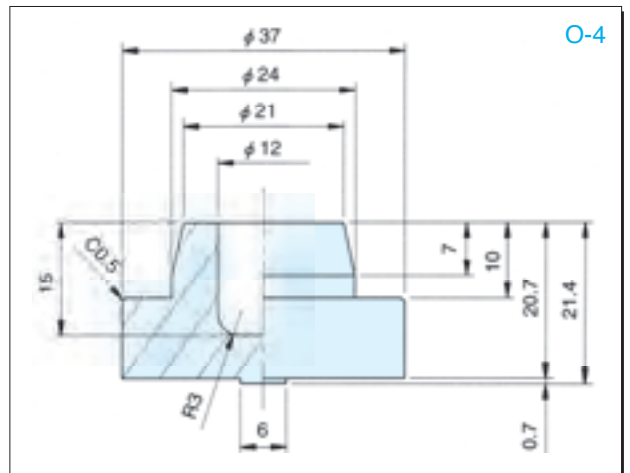
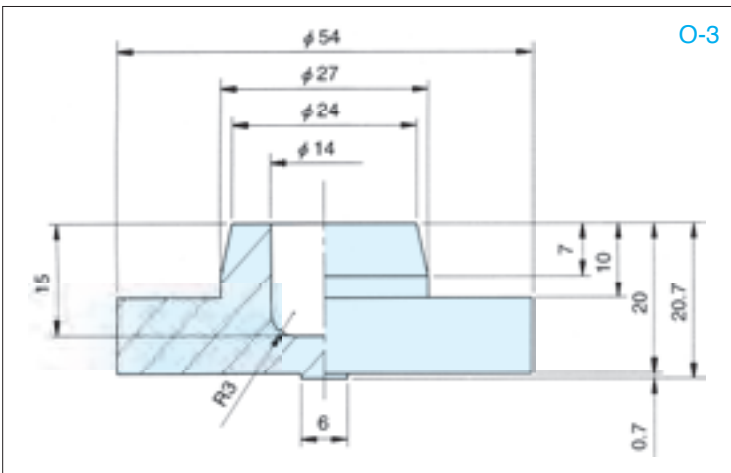
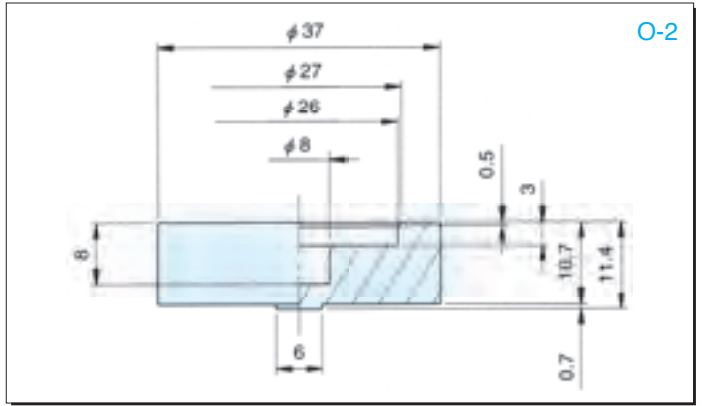
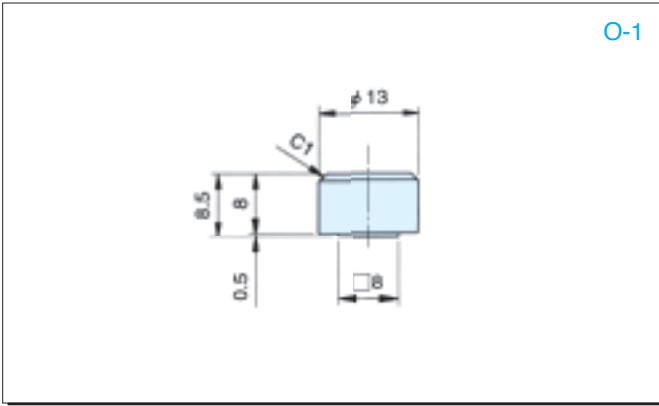

Please inform us if you require any of the SUS fittings/nuts detailed on P-1, P-2, and P-3. If we do not receive any instructions then the material used will be as shown in the diagram.

# Special back/Machining

## Dimensions and specification of lining belts

Type	Backside Material	Thickness (mm)	Color	Minimum pulley diameter (mm)			Features
Attaching of coarse top	PVC	Approximately 5.2	Green	60			Suits conveyance due to use of PVC with a high friction coefficient and anti-slip shape.
Synthetic leather coating	Synthetic leather	2	Gray	50			Suits use with easily damaged parts as the surface of the synthetic leather is quite soft.
polyurethane form coating	Polyurethane {Hardness (JIS A) 20,30,40,55 4 types available}	5, 10	Green,White	20	5	60	Features excellent cushioning performance and thus suits protection during tractor transportation and items to be conveyed.
					10	120	
				30	5	30	
					10	60	
				40	5	35	
					10	70	
55	5	40					
	10	80					

Please consult us regarding other types of coatings (synthetic rubber).

## Belt processing (machined and perforated tooth /rear sides)

Please consult us regarding the range we can manufacture and specify the processing details.

### Example of processing

Tooth-side machining

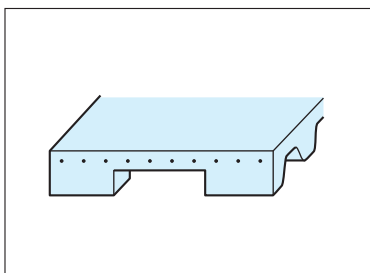
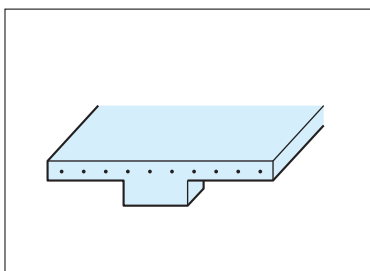
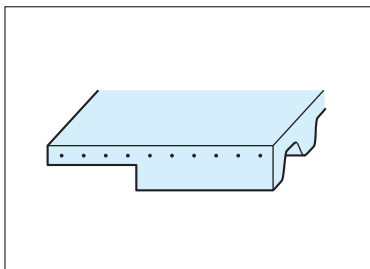

Backside machining

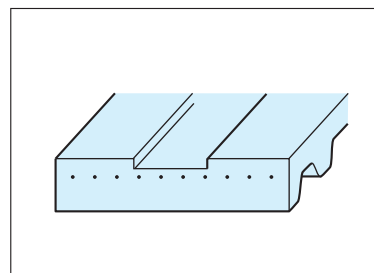
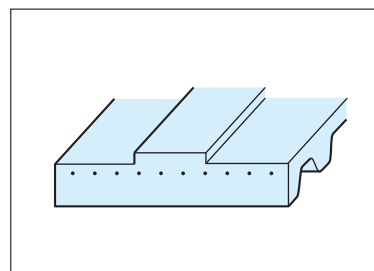
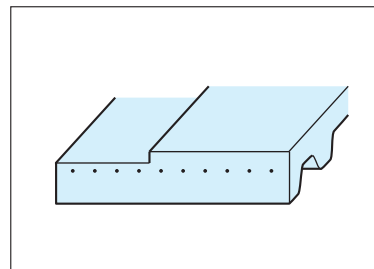

Perforations

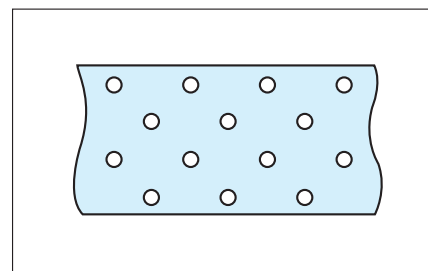
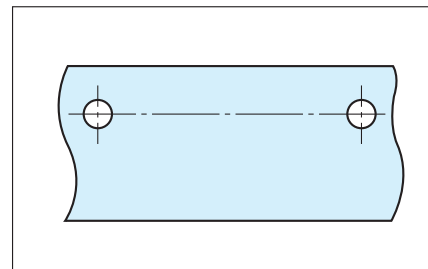

# Design instructions

## Initial tension (mounting tension)

Please decide the initial tension according to the maximum effective tension generated during conveyance.

The initial tension should be distributed across the entire circumference of the belt while stopped or idling.

When belts are being used they have a tense side and a loose side, with the tension gap between both those sides being referred to as the effective tension.

The tension gap can be used to generate torque or conveyance capability via pulleys.

Please ensure to provide the initial tension in thus preventing the belt from being too loose on the loose side when using a toothed belt.

Too much looseness on the loose side is generally caused by the initial tension being too low.

### 1. Determining the effective tension

Please use the actual load (actual torque and actual power) in determining the effective tension using the following formula.

$$U = \frac{2 \times 10^3 \times M_{dj}}{d_p} \quad \text{or} \quad U = \frac{19.1 \times 10^6 \times P_j}{n \times d_p}$$

U : Effective tension (N)  
 M<sub>dj</sub> : Actual torque (Nm)  
 P<sub>j</sub> : Actual power (kW)  
 d<sub>p</sub> : Pulley diameter (mm)  
 n : Pulley rotation (rpm)

### 2. Reference values for use in the initial tension setting range

The initial tension setting range utilizes reference values only and hence compatibility should be ensured before use.

#### a. For power transmission

Please set the initial tension (F<sub>v</sub>) for power transmission with reference to the following range.

$$0.5U < F_v < 0.5U + 0.2F$$

If 0.5U + 0.2F exceeds 0.5F then the value should be a maximum of [0.5F].

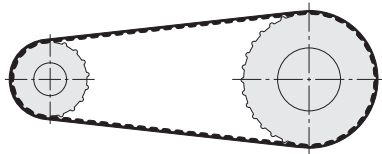

F<sub>v</sub> : Initial tension (N)  
 F : Allowable tension (N)

#### b. For linear drives

Please set the initial tension (F<sub>v</sub>) for a linear drive (see page 86) with reference to the following range.

$$U < F_v < U + 0.2F$$

If U + 0.2F exceeds 0.5F then the value should be a maximum of [0.5F].

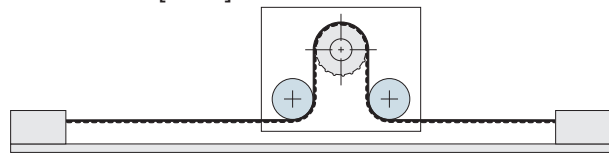
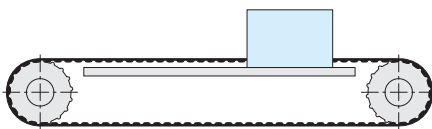

#### c. For conveyance

Please set the initial tension (F<sub>v</sub>) for conveyance with reference to the following range.

$$0.5U < F_v < 0.5U + 0.2F$$

If 0.5U + 0.2F exceeds 0.5F then the value should be a maximum of [0.5F].



### 3. Verifying the initial tension

The tension can be verified using the following three methods.

#### a. Verification via the number of belt vibrations

Slapping (tapping) a tense belt results in vibrations.

Please determine the belt tension according to the number of vibrations and the following formula.

$$F_v = 4 \times f^2 \times m \times L^2$$

f : Number of vibrations (Hz)  
m : Belt weight per meter (kg/m)  
L : Span length (m)

\*Reference values for m are described on pages 22 to 53 but actual measurements should be made.

#### b. Verification via the force of the push and amount of deflection (simplified method)

Please determine the force that pushes the belt (or pulls the belt) using the following formula.

$$P_k = F_v / 16$$

Please set the amount of deflection to be the following value while the belt is being pushed with the above determined force.

$$\delta = L \times 1000 / 64$$

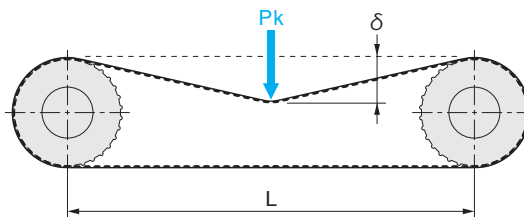

Pk : Pushing force (N)  
Fv : Desired tension (N)  
delta : Amount of deflection (mm)  
L : Span length (m)

#### c. Verification via the elongation of the belt (simplified method)

Load on the belt results in elongation (elastic deformation) of it.

The tension can then be easily verified using this characteristic.

The elongation rates to use in ensuring allowable tension F of each individual belt are as shown below.

Flex type : approximately 0.4% -> approximately 4mm/m

Linear type : approximately 0.4% -> approximately 4mm/m

[Example of determining elongation rate]

The elongation rate with 2500N and the T20 Flex type can be determined using the following formula.

If the allowable tension is set to be 8280N,

$$\text{Elongation rate} : \Delta \ell = \frac{4\text{mm/m} \times 2500\text{N}}{8280\text{N}} = \text{approximately } 1.2\text{mm/m}$$

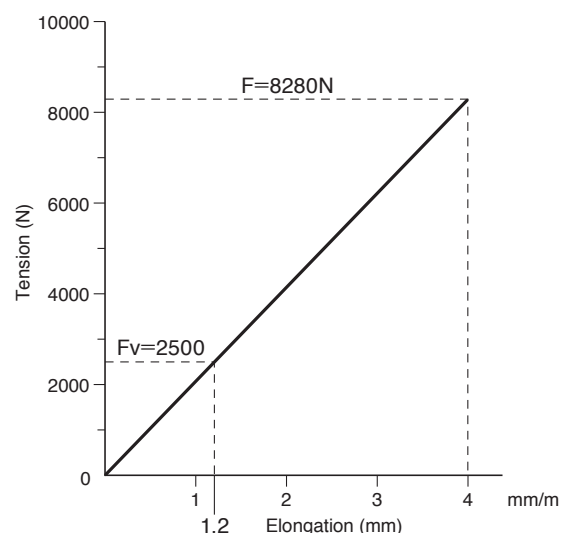
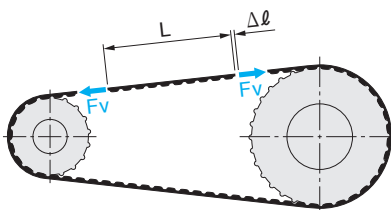

# Design instructions

## Instructions when using teethed pulleys

- ⚠ Caution** • Please ensure to implement the following when using pulleys that have been additionally processed.
  - Removal of all burrs and sharp edges from the processed parts
  - The dimensional accuracy verified after processing
  - The pulley strength verified after processing
  
- ⚠ Caution** • When mounting a flange on a pulley please confirm that there are no foreign objects on the section that fits between the main body and the flange. Please also ensure to fix the flanges in place using swages in thereby preventing any backlash.
  
- ⚠ Caution** • If screws are used to fix flanges in place the screws may then loosen due to vibration etc. and with some types of usage. Please therefore ensure to conduct periodic inspections and retighten them when necessary.
  - The teethed belts can lean to one side while being operated due to any deviation in the tracks of the pulley shafts (pulley alignment), characteristics of the belt, and other factors, and hence please ensure to install any instruments in a way that prevents them from dropping off the flanges or other parts.
  - Minimum number of pulleys  
Please refer to the following table regarding use of pulleys as the minimum number of them can vary depending on the speed of rotations.

Speed of rotations (rpm)	MA3	MA5	MA8	AT5	AT10	AT20	T5 DT5	T10 DT10	T20	MXL	XL	L	H DH	XH	
Up to 600	18	15	20	15	15	18	12	14	18	12	10	10	14	18	
Up to 720			22			20			22			20		12	20
Up to 900			24			22			24			22		16	24
Up to 1200		16	18	16	14	18		14	16			18			
Up to 1800	20	20	26	16	20	24	14	18	24	14	12	14	18	24	
Up to 3000	22	24	28	18	22	26	16	20	26	16	12	16	20	26	

- ⚠ Caution** • Please set the appropriate amount of tension for the belt in accordance to page 76. Inappropriate tension can result in early damage to the belt and shaft.
  
- ⚠ Caution** • All the belts should be replaced at the same time when multiple belts are used. Failure to observe this could result in early damage.
  
- ⚠ Caution** • Any deviation of the pulley alignment could result in early damage to the belt or it dropping off the flanges.  
Please ensure to use the pulleys within the range shown in the table below. (Quoted from JIS K 6373)

Belt width (mm)	Up to 25.4	25.4 to 75	Over 75
$\tan \theta$	Up to $\frac{6}{1000}$	Up to $\frac{4.5}{1000}$	Up to $\frac{3}{1000}$

\*Merely reference values for use in making adjustments and do not guarantee that belt will not drop off.

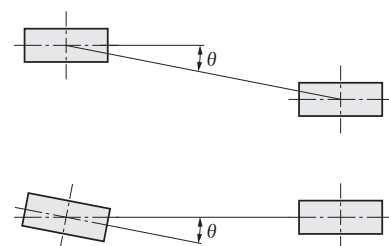



• Idler

- In the case that there is no other choice but to use an idler then please ensure to install it on the loose side.
- Please install the idler inside the belt if at all possible.  
Ensure at least the minimum number of pulley teeth is met when installing inside.
- When installing one outside please use crown-less flat pulleys with a diameter that is at least the equivalent of those shown in the table below.

Belt models	Minimum idler diameter (mm)
MA3	30
MA5, AT5	40
MA8, AT10	80
AT20	180
T5	30
T10	70
T20	180
MXL	15
XL	30
L	50
H	90
XH	180

Mounted from the inside

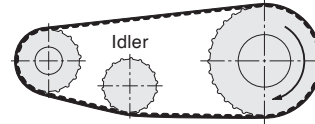

Mounted from the outside

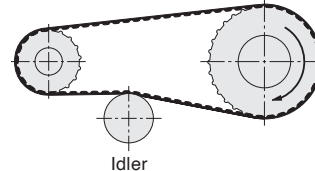

• Minimum adjustment range for the distance between shafts

After taking into consideration the clearance between the mount and pulling shafts please refer to the table below for the minimum adjustable range for the distance between the shafts.

Distance between shafts (mm)	External adjustment range (mm)
Up to 600	5
Over 600 to 1000	10
Over 1000 to 1500	15
Over 1500 to 2000	20
Over 2000 to 2500	25
Over 2500 to 3000	30
Over 3000	Distance between shafts x 0.01

Belt models	Internal adjustment range (mm)
MA3, T5, XL, MXL	5
MA5, AT5, L	10
MA8, AT10, T10, H, T5-V, FAT1	15
AT20, T20, XH, T10-V, AT10-V	40

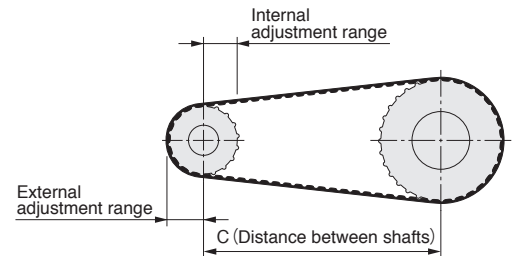

Please ensure to take into consideration the external diameter of the flange with flanged pulleys and utilize a slightly wider range.

## Other instructions

- Warning** • UH01 (Material symbol: G) includes mold-proof and antimicrobial features; note however, that periodic cleaning is still necessary.  
Confirmation tests took place based on ASTM G-21-70. (Please refer to page 84 for more details.)
- Caution** • Please ensure to select all belts according to their conditions of use and verify their compatibility before using them.

  - Please ensure to verify compatibility before use in the case that stringent forward/reverse and acceleration/deceleration conditions are required.
  - Profile belts
    - Please ensure to verify the required molding width and number of pulley teeth.
    - Please ensure to verify compatibility before use in the case that other attachments are mounted on the profile or in any case where the profile will be exposed to vibrations or impact load from intermittent feeds etc.
  - Aramid fiber for use with the Linear type and stainless-steel cords for the Flex type are available if the belt will get wet. Please ensure to verify compatibility before use.
  - Please ensure to use non-metal aramid fiber for any food machinery.
  - With use of multiple belts
    - Please ensure to use matched-set belts.
    - Please ensure to configure the belt tension and pulley alignment so that they can be adjusted per individual belt.
    - Please refer to page 20 for the method used to identify the dimensions of the different models.

Example utilization of matched-set

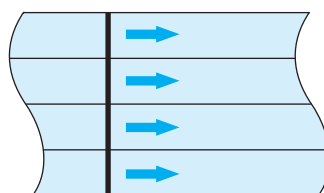

Align the marks and set the belts in place.  
(Matched-setting of four belts)

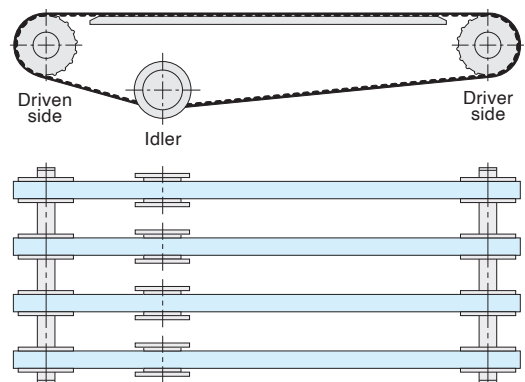

# Damage to belts, causes, and countermeasures

Damage	Causes	Countermeasures
Cuts in the belt	<ol style="list-style-type: none"> <li>1. Overloading</li> <li>2. Overloading due to an accident with a machine</li> <li>3. Excessive sudden load</li> <li>4. Too small a pulley diameter</li> <li>5. Bending of the belt</li> <li>6. Running on the flange</li> <li>7. Presence of a foreign object</li> <li>8. Reduced strength due to corrosion of the tension member (steel cord)</li> </ol>	<p>Change the design (increase the size of the belt). Prevent recurrence of the accident.</p> <p>Change the design or eliminate any sudden load, and install a torque limiter.</p> <p>Change the design (increase the pulley diameter). Pay more attention to the handling.</p> <p>Readjust the alignment and review the flange shape. Improve the environment or install a protective cover.</p> <p>Improve the environment or replace with stainless-steel cord or aramid cord.</p>
Abrasion on the sides of the belt	<ol style="list-style-type: none"> <li>1. Pulley alignment failure</li> <li>2. Pulley alignment failure due to a lack of stiffness in the shaft and bearings</li> <li>3. Bending of the pulley flange and a defective shape</li> <li>4. Rough or scratched surface of the pulley flange</li> <li>5. High friction coefficient of the pulley flange</li> <li>6. Interference with the guide rail or other parts</li> </ol>	<p>Readjust the alignment.</p> <p>Change the specifications after taking the shaft load into consideration.</p> <p>Correct any bending of the pulley flange. Replace with a new flange.</p> <p>Replace with a more appropriate flange.</p> <p>Replace with a more appropriate flange.</p> <p>Eliminate any interference with the guiderail or other parts.</p>
Abrasion of the belt teeth (all teeth)	<ol style="list-style-type: none"> <li>1. Overloading</li> <li>2. Excessive pulling of the belt (excessive tension)</li> <li>3. Exposure to an abrasive powder and dust filled environment</li> <li>4. Excessively loose belt (failed to engage with the pulley)</li> <li>5. Friction from the guiderail</li> <li>6. High-temperature environment or too much heat from the pulleys</li> <li>7. Abnormal external diameter of the pulleys</li> <li>8. Defective pulley teeth shape</li> <li>9. Scratches on the pulley and corrosion</li> <li>10. Defective pulley surface roughness</li> </ol>	<p>Change the design (increase the size of the belt). Set a more appropriate tension. Improve the environment or install a protective cover.</p> <p>Set a more appropriate tension.</p> <p>Reduce the friction (replace with a belt lined with fabric on the teeth-side etc.)</p> <p>Decrease the environmental temperature or control the heat generated by the pulleys.</p> <p>Replace with a normal pulley.</p> <p>Replace with a normal pulley.</p> <p>Replace with a new pulley.</p> <p>Replace with a normal pulley.</p>
Abrasion on the bottom of the belt teeth	<ol style="list-style-type: none"> <li>1. Excessive pulling of the belt (excessive tension)</li> <li>2. Abnormal external diameter of the pulley</li> <li>3. Defective pulley tooth shape</li> <li>4. Defective pulley surface roughness</li> </ol>	<p>Set a more appropriate tension.</p> <p>Replace with a normal pulley.</p> <p>Replace with a normal pulley.</p> <p>Replace with a normal pulley.</p>
Abrasion on the tips of the belt teeth	<ol style="list-style-type: none"> <li>1. Excessive pulling of the belt (excessive tension)</li> <li>2. Rough or scratched surface of the guide rail, etc. or high friction coefficient</li> <li>3. Interference from the guide rail, etc.</li> <li>4. Defective pulley surface roughness</li> </ol>	<p>Set a more appropriate tension.</p> <p>Replace with a more appropriate guide rail, etc.</p> <p>Eliminate any interference from the guide rail or other parts.</p> <p>Replace with a normal pulley.</p>
Cracking to the belt teeth root rubber	<ol style="list-style-type: none"> <li>1. Overloading</li> <li>2. Excessive sudden load (including accidentally)</li> <li>3. Shortage of number of teeth in mesh</li> <li>4. Excessive tension</li> <li>5. Small idler on the backside</li> </ol>	<p>Change the design (increase the size of the belt). Change the design or eliminate any sudden load.</p> <p>Increase the number of pulley teeth or increase the number of teeth in mesh via use of an idler.</p> <p>Set a more appropriate tension.</p> <p>Change the design (increase the diameter of the backside idler).</p>
Partial cutting of the tension member	<ol style="list-style-type: none"> <li>1. Presence of foreign objects</li> <li>2. Excessive force when installing the belt from a wrench or other tool</li> <li>3. Partial bending of the belt</li> <li>4. Fatigue from the side due to pulley alignment failure</li> <li>5. Small pulley diameter</li> <li>6. Reduced strength due to corrosion on the tension member</li> </ol>	<p>Improve the environment or install a protective cover. Pay more attention to the handling during installation.</p> <p>Pay more attention to the handling (avoid any forced bending during handling and storing). Readjust the alignment.</p> <p>Change the design (increase the pulley diameter). Change the tension member material, improve the environment, and install a protective cover.</p>
Skipping of the belt teeth	<ol style="list-style-type: none"> <li>1. Overloading (overloading with sudden load)</li> <li>2. Overloading due to an accident with a machine</li> <li>3. Excessive sudden load</li> <li>4. Shortage of number of teeth in mesh</li> <li>5. Lack of tension</li> <li>6. Pulley alignment failure due to a lack in stiffness of the shaft and bearings</li> <li>7. Small pulley diameter</li> <li>8. Lack of consideration to the inertia force when starting and stopping</li> <li>9. Abnormal external pulley diameter</li> <li>10. Defective pulley tooth shape</li> <li>11. Defective pulley surface roughness</li> </ol>	<p>Change the design (increase the size of the belt). Prevent the recurrence of accidents.</p> <p>Change the design or eliminate any sudden load. Increase the number of pulley teeth or increase the number of teeth in mesh via use of an idler.</p> <p>Set a more appropriate tension.</p> <p>Change the design after taking the shaft load into consideration.</p> <p>Change the design (increase the pulley diameter). Change the design.</p> <p>Replace with a normal pulley.</p> <p>Replace with a normal pulley.</p> <p>Replace with a normal pulley.</p>

Damage	Causes	Countermeasures
Vertical tearing of the belt	<ol style="list-style-type: none"> <li>1. Running of the belt outside the pulley</li> <li>2. Running on to the pulley flange</li> <li>3. Forced insertion of the belt when installing the belt (forcibly running the belt over the flange, etc.)</li> <li>4. Inappropriate (excessive) flange alignment</li> </ol>	<p>Readjust the alignment. Readjust the alignment and review the flange shape. Pay attention to the handling during installation.</p> <p>Change to a more appropriate flange alignment.</p>
Abrasion of the belt backside rubber	<ol style="list-style-type: none"> <li>1. Misalignment of the pulley and contacting the backside rubber</li> <li>2. Contact with the machinery frame or other objects</li> </ol>	<p>Readjust the alignment.</p> <p>Remove anything it can come in contact with.</p>
Cracking to the belt backside rubber	<ol style="list-style-type: none"> <li>1. Small pulley diameter</li> <li>2. Too low a temperature environment</li> <li>3. Contact with the machinery frame or other objects</li> <li>4. Degradation of the rubber due to attached objects or the environment</li> </ol>	<p>Change the design (increase the pulley diameter). Increase the environmental temperature. Eliminate any objects it can come in contact with. Improve the environment and install a protective cover.</p>
Elongation of the belt	<ol style="list-style-type: none"> <li>1. Overloading</li> <li>2. Excessive sudden load (including accidentally)</li> <li>3. Excessive pulling of the belt (excessive tension)</li> <li>4. Running on to the flange</li> <li>5. Oil etc. contaminating the rubber part of the main body.</li> </ol>	<p>Change the design (increase the size of the belt). Change the design or eliminate any sudden load. Set a more appropriate tension. As described in the left *1 Change the oil and change the belt specifications.</p>
Seemingly elongated belt	<ol style="list-style-type: none"> <li>1. Too short a distance between shafts</li> <li>2. Too loose a tension pulley</li> <li>3. Abrasion of the pulley external diameter</li> <li>4. Abrasion of the belt</li> <li>5. Too loose a shaft</li> </ol>	<p>Change the shaft distance to a more appropriate value. Ensure a better installation. Improve the environment and implement countermeasures against any abrasion. As described in the left *2 Tighten and strengthen the shaft fixture.</p>
Abrasion of the pulley teeth	<ol style="list-style-type: none"> <li>1. Overloading</li> <li>2. Excessive pulling of the belt (excessive tension)</li> <li>3. Inappropriate pulley material (too soft)</li> <li>4. Exposed to abrasive powder and dust</li> </ol>	<p>Change the design (increase the size of the belt). Set a more appropriate tension. Change to use of a harder material and perform surface hardening treatment. Improve the environment or install a protective cover.</p>
Abnormal noise	<ol style="list-style-type: none"> <li>1. Overloading</li> <li>2. Excessive pulling of the belt (excessive tension)</li> <li>3. Pulley alignment failure</li> <li>4. Abnormal pulley external diameter</li> <li>5. Defective pulley tooth shape</li> <li>6. Belt width wider than the pulley width</li> <li>7. Originating from the pulley hitting the belt</li> <li>8. Interference from the pulley flange</li> <li>9. Presence of foreign objects or dirt</li> <li>10. Significant friction between the belt and the pulley</li> <li>11. Too high a belt speed</li> <li>12. Co-vibration</li> </ol>	<p>Change the design (increase the size of the belt). Set a more appropriate tension. Readjust the alignment. Replace with a normal pulley. Replace with a normal pulley. Change the design. Replace with a belt lined with fabric on the teeth-side. As described in the left *1 Improve the environment or install a protective cover. Set a more appropriate tension, replace with a belt lined with fabric on the teeth-side and apply lubricant. Decrease the belt speed, replace with a belt lined with fabric on the teeth-side and apply lubricant. Change the tension and speed.</p>
Detaching of the profile and damage	<ol style="list-style-type: none"> <li>1. Too thick a profile</li> <li>2. Repeated load applied to the profile</li> <li>3. Contact with the machinery frame or external objects (interference)</li> <li>4. Pulleys exposed to too much vibration</li> <li>5. Too low a temperature environment</li> <li>6. Excessive load on the insert fitting</li> </ol>	<p>Change to a thinner profile or increase the number of pulley teeth. Change the design and review the structure. Remove any contacting objects.</p> <p>Review the usage conditions and method. Increase the environmental temperature. Mitigate any excessive stress and review the profile shape.</p>

# Belt dimension tolerance

Standard tolerance values for the belt width and thickness are as provided in the table below.

## Belt width tolerance

### •MA belt, AT belt (including Flex, Joint, and Linear)

(mm)

Standard nominal width (belt width)	MA3 MA5 AT5 MA5-V	MA8 AT10 AT10-V FAT1	AT20
007 010	+0.5 -0.7	—	—
015 020	+0.8 -1.0	+0.8 -1.2	—
025 040 050	±1.0	±1.2	±1.5
075 100	—	±1.5	+1.5 -2.0

### •Trapezium teathed belt: belt in meters, belt in inches (including Flex, Joint, and Linear)

(mm)

Standard nominal width (belt width)		T5 MXL XL T5-V DT5	T10 L H T10-V L-V F20-V F12 F20	T20 XH DT10 DH F60
Meter	Inches			
007 010	013 019 025 031 037	+0.7 -0.6	+0.7 -0.6	—
015 020 025 030 040 050	050 075 100 150 200	+0.7 -1.0	+0.7 -1.0	+0.7 -1.2
075	300	—	+1.0 -1.5	+1.0 -1.8
100	400	—	+1.0	+1.0 -2.0
150	500 600	—	-2.0	—

## Belt thickness tolerance

### •Flex type

(mm)

Model	Thickness tolerance
T5, XL	+0.4 -0.1
MA3, MA5, AT5, DT5 F12, F20	±0.3
MA8, AT10, T10, DT10 L, H, DH, F60	±0.4
AT20, T20, XH	±0.45

### •Flex type, Linear type

(mm)

Model	Thickness tolerance
MA3, MA5, AT5, T5 MXL, XL, L, F20	±0.3
MA8, AT10, AT20 T10, T20, H, XH MA5-V, T5-V AT10-V, T10-V F20-V, FAT1	±0.4
150-T10, 400-T10 600-H	±0.5

\*Please note that ±0.1 should be added to the above tolerances provided for back-side low-hardness belts, high-friction nylon faced belts, and belts with a bac-kside surface grain.

# Rubber Material

## Material characteristics

The material complies with the 1959 notification No. 370 of the Ministry of Health, Labor, and Welfare (1986 revised notification No. 85 of the Ministry of Health, Labor, and Welfare) regarding the Food Sanitation Act: Standards for Rubber Equipment (excluding baby bottles etc.) and Containers and Packaging.

Item		Material name(code)	U496 (A)	U497 (E)	U478 (D)	UH01 (G)	(Reference) Chloroprene rubber
Mechanical properties	Hardness [JIS K 6253]		A91	A91	A87	A92	A80
	Tensile strength (MPa) [JIS K 6251]		45.3	45.3	41.6	40.4	15.7
	100% modulus (MPa) [JIS K 6251]		8.5	8.5	6.1	9.2	8.8
	Elongation at break (%) [JIS K 6251]		530	530	590	510	190
	Tearing strength (N/mm) [JIS K 6252]		110	110	100	110	39
Other properties	Ozone resistance [JIS K 6259] (20% extension, 50pphm) (40°C×168hrs)		No cracking	No cracking	No cracking	No cracking	Cracking
	Food Sanitation Act (Japan)		Compliant	Compliant	Compliant	Compliant	Noncompliant
	Color		Translucent natural color	White	Translucent natural color	White	Black

\*The values in the table are actual measurements and are not standard values.

### Oil resistance

A comparison with conventional synthetic rubber (CR and NBR) is shown in the figure.

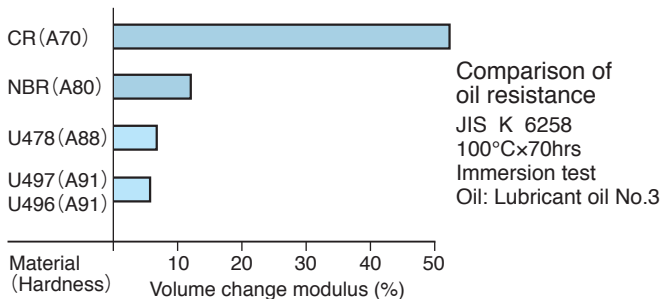

### Abrasion resistance

Iron Rubber has better abrasion properties than other types of synthetic rubber. The figure provides a comparison of the abrasion properties with other types of synthetic rubber.

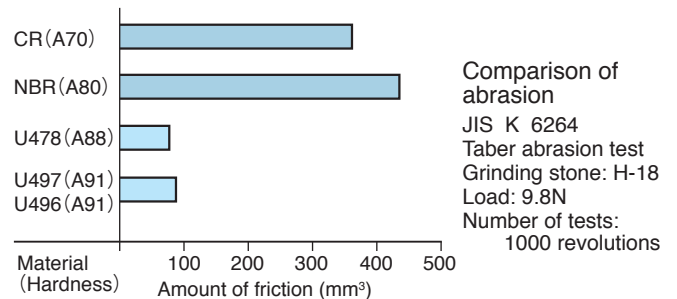

### Iron Rubber features antistatic specifications.

Belts made from high-polymer materials can generate static electricity from friction during use that can then result in anything from the conveyor being rejected due to dust having attached to it and broken insulation; however, U496, U497, U478 and UH01 feature antistatic specifications.

### Surface electricity resistance (sample: test piece)

Material name	Surface electricity resistance( $\Omega/\square$ )
U496	$10^{10}$
U497	$10^{10}$
Common urethane	$10^{13}$

\*This is merely an example of test results and in no way guarantees the performance.

# Rubber Material

## Mildewproof & antimicrobial specifications (UH01)

- This product is used in environments prone to the outbreak of molds, such as food and transportation lines and places high in humidity.  
Foodstuff etc. can be directly loaded onto the belt as it complies with the Food Sanitation Act (Japan).

### Antimicrobial properties

Viable cell count after cultivation (24 hours at 30°C) through actual contact trial examination

Bacterial species	Viable cell count (cells/ml)	
	Escherichia coli (E. coli) ( $1 \times 10^6$ )	S. aureus ( $3.6 \times 10^5$ )
U497	$9.2 \times 10^6$	$5.5 \times 10^6$
UH01	Less than $10^2$	Less than $10^2$

\*This is an example of a test result and is not a guarantee of performance.

### Mildewproof properties

Condition after a 28-day ASTM method test (test conforming to ASTM G-21-70)

[Test results]

**U497** Mold outbreak in 60% or more of the sample area

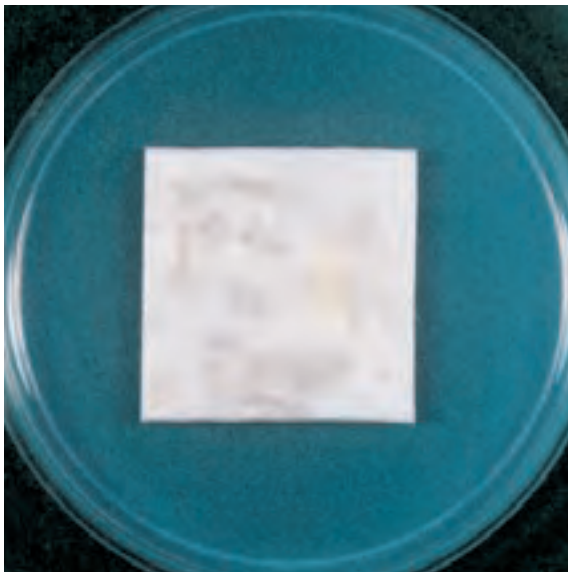

**UH01** No mold outbreak

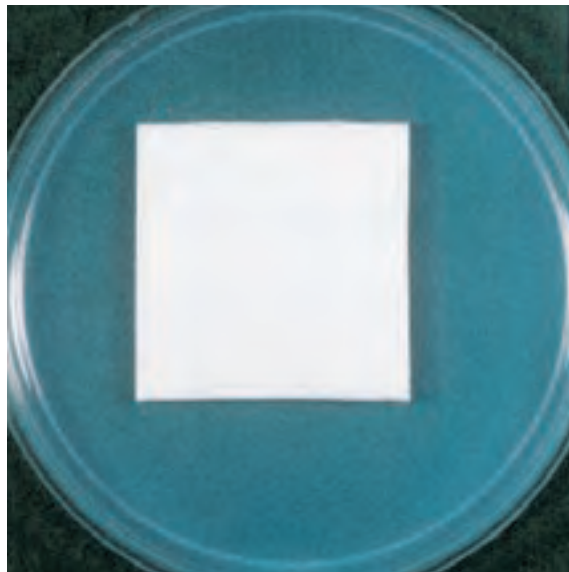

### Molds prevented

- Fusarium graminearum
- Neurospora crassa
- Phoma
- Aspergillus niger
- Penicillium citrinum (penicillium)
- Cladosporium cladosporioides
- Aureobasidium pullulans
- Chaetomium globosum

Please consult with us in advance if you have plans to use the devices with the mildewproof/antimicrobial belt outside of Japan.

## Chemical resistance

- The levels of influence on Iron Rubber of chemicals and oil are shown below.  
The levels of influence are merely reference values and hence more testing is necessary for actual use.
- Please confirm compatibility before using it in a belt.

Evaluation symbol	Evaluation level
◎	No influence
○	A slight amount of influence but no usage limitations
△	Usage limitations
×	Serious influence

Chemicals	Evaluation	Chemicals	Evaluation	Chemicals	Evaluation
Acetic acid 5%	×	Aqueous sodium hydroxide 5%	×	n-hexane	○
Glacial acetic acid (38 °C)	×	Aqueous sodium hydroxide 10%	×	Hydrazine	△
Acetic acid anhydride	△	Potassium hydroxide solution 5%	×	N-methylpyrrolidone	×
Hydrochloric acid 5%	×	Sodium bichromate 20%	○	Isooctane	○
Nitric acid 10%	△	Sea water	○	Isopropyl alcohol	○
Sulfuric acid 20%	×	Acetone	×	Kerosene	○
Fuming sulfuric acid 20%	×	Methyl ethyl ketone	×	Gasoline	○
Sulfurous acid	△	Ethyl alcohol	△	Jet fuel	○
Formic acid	×	Methyl alcohol	△	Linseed oil	◎
Hydro cyanic acid	△	Acetic ether	×	Ricinus	◎
Hydrofluoric acid 10%	×	Carbon tetrachloride	×	Naphthalene	○
Hydrogen sulfide	△	Benzene	×	Soy bean oil	◎
Chlorine gas	×	Carbon disulfide	△	Beer	◎
Aqueous solution of trisodium phosphate	◎	Diocetyl phthalate	◎	Phenol	△
Aqueous solution of citric acid	◎	Ethyl chloride	△	Ethylene tetrachloride	×
Anhydrous bromine (solution)	×	Ethylene glycol	○	Xylene	×
Aqueous solution of acidum boricum	◎	Ethylene oxide	○	Fuel oil A	○
Aqueous solution of ammonium chloride	○	Fluosilicate	○	Fuel oil B	△
Aqueous solution of calcium chloride	◎	Formaldehyde 40%	△	Fuel oil C	△
Aqueous solution of calcium hypochlorite	◎	Chlorobenzene	×	Dimethylformamide	×
Aqueous solution of sodium chloride	◎	Cyclohexane	○	Tetrahydrofuran	×
Aqueous solution of ammonium nitrate	○	Dibutyl phthalate	◎	Toluene	×
Aqueous solution of ammonium hydroxide	△	Glycerin	◎	Hydrogen peroxide water	△

# Applications

We construct (manufacture/custom-fabricate) optimized belt lines to match the requisite parameters & dimensions of any task.

- Iron Rubber belts further expand the scope of your system design.

## Linear drive

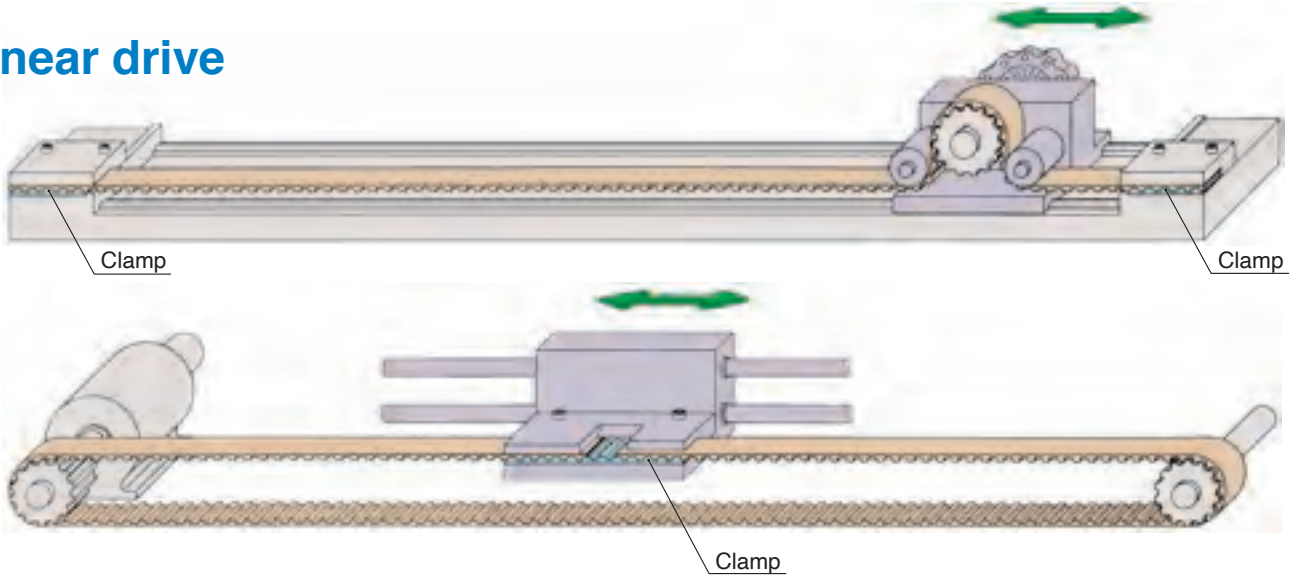

## Accumulation conveyor

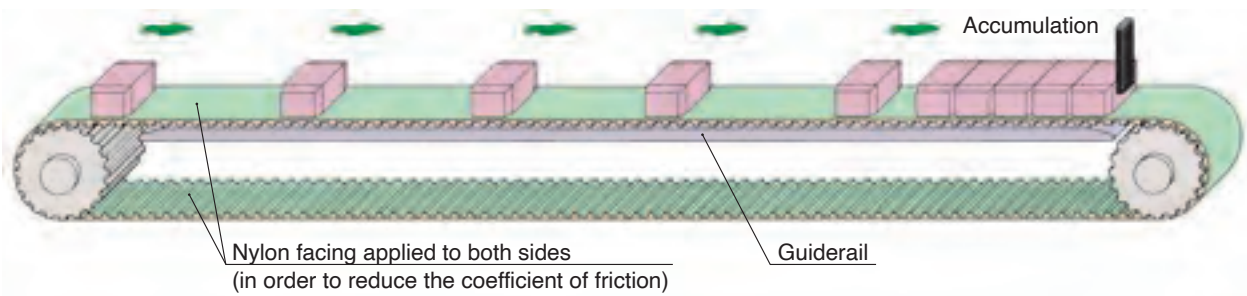

## Sandwich conveyor

- Transportation of thin sheet material

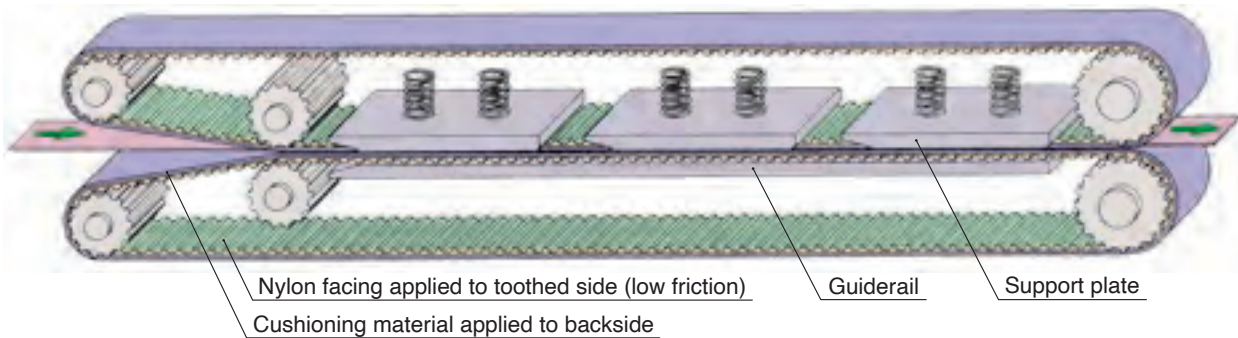

## Synchronous conveyor

- Transportation of long bars

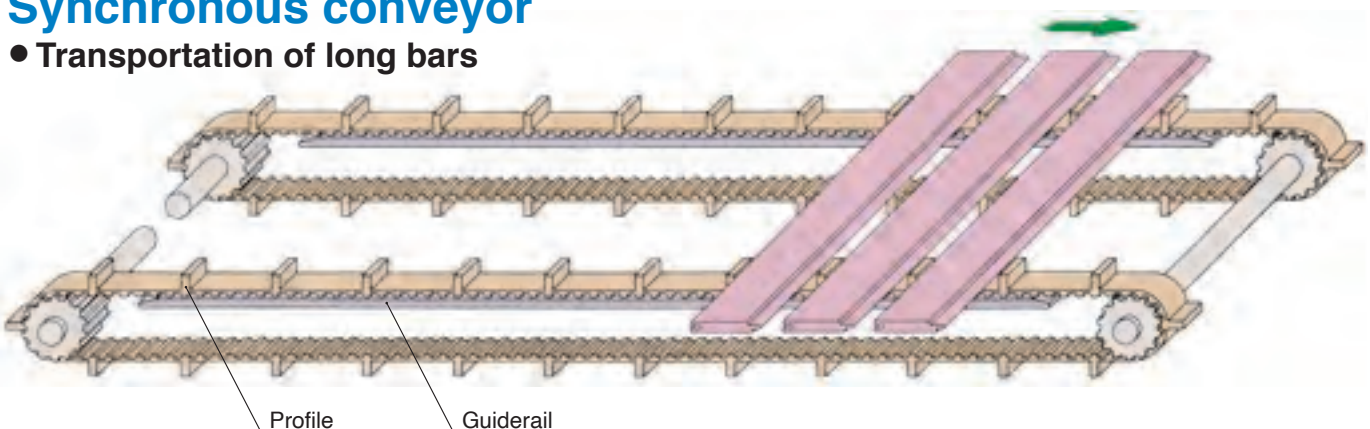



## Vertical conveyor

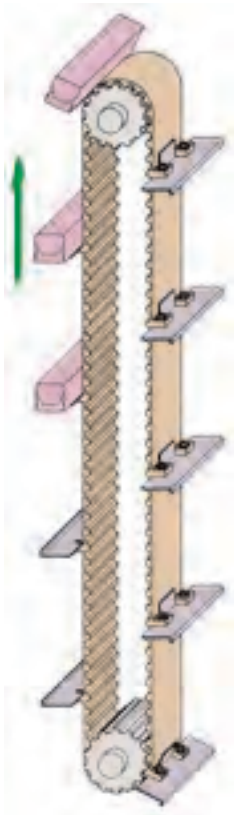

## Magnetic conveyor

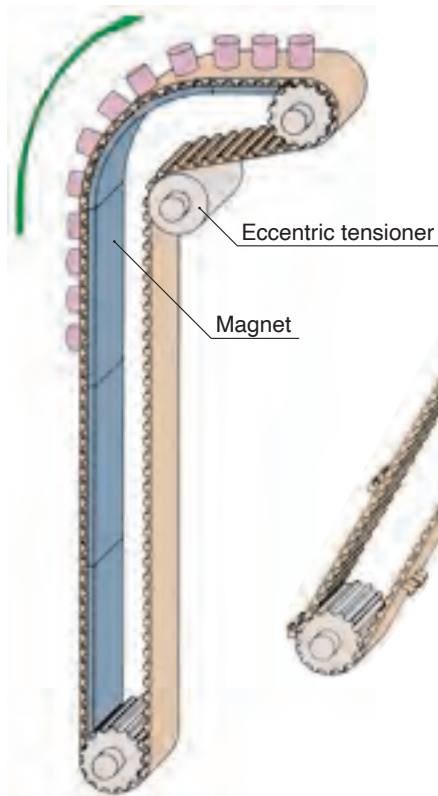

## Inclined conveyor

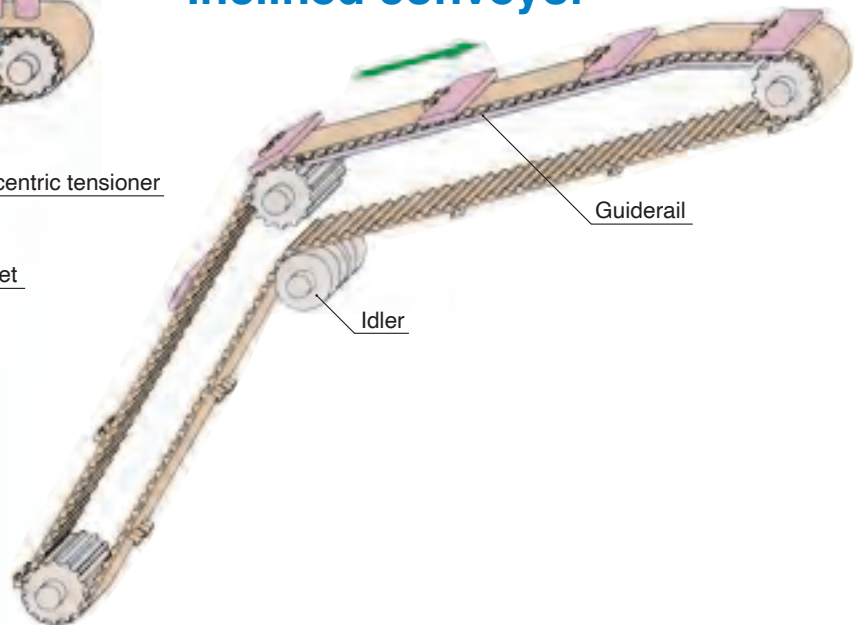

## Example of combination at self-tracking belt

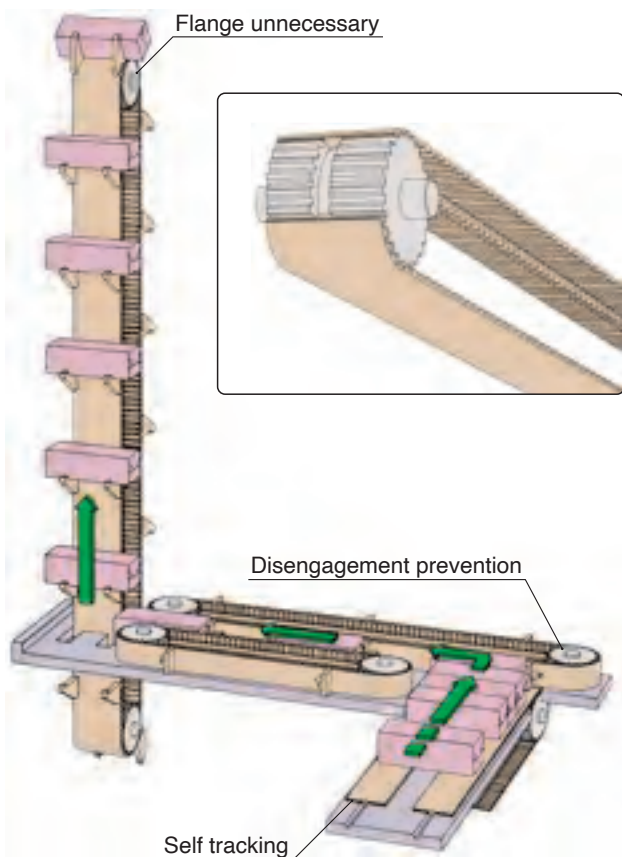

## Vacuum conveyor

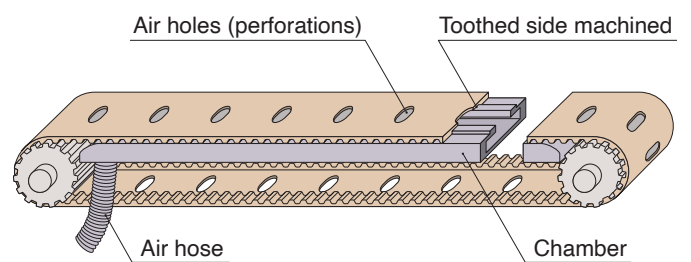

## Conveyance of circuit boards

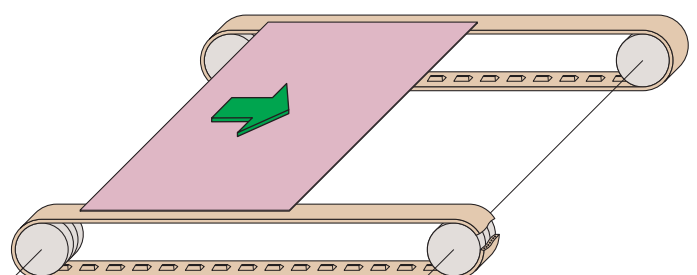



---

©**NOK CORPORATION** Printed in Japan

**Overseas Sales & Marketing Department Sales & Marketing Division**  
1-12-15 Shiba Daimon Minato-ku, Tokyo, Japan. Zipcord 105-8585.

The contents is subject to change without notice.

---

All compatibility data, application information, design & material information and technical deta in this catalogue are compiled as a reference material to make a basic packing selection.  
A selected standard design from this catalogue may not comform to the actual use of an application, clue to unknown factors in the application.  
Please comfirm the actual compatibility of a selected product with your appli-cation before using it.